



HYDRAULIC EXCAVATOR

**OPERATOR'S
MANUAL**

Robex

145 CR-9

145 CRD-9

145 LCR-9

HYUNDAI







EC Declaration of conformity - update 04/01/10

1. We hereby declare that the following machine comply with the machine directive 2006/42/EC, EMC-directive 2004/108/EC, Non-road mobile machinery emission directive 97/68/EC (amended by 2002/88/EC, 2004/26/EC, 2006/105/EC) and noise emission 2000/14/EC (amended by 2005/88/EC).

Excavator	Model :	*****
	Serial Nr. :	***

2. Manufacturer	Hyundai Heavy Industries Co. Ltd. 1000, Bangeojinsunhwan-doro, Dong-Ku Ulsan The republic of Korea
-----------------	---

Authorized representative : Owner of the technical file for machine production. (TCF : Technical Construction File)	Hyundai Heavy Industries Europe N.V. Vossendal 11 2440 Geel Belgium
--	--

3. Harmonized European directives :	EN474-1:2006 +A1:2009, EN474-5: 2006, EN ISO 12100-1:2003, EN ISO 12100-2:2003, EN ISO 2867:2008, EN ISO 7096:2008, EN ISO 6683:2008, EN ISO 2860:2008, EN ISO 6682:2008, EN ISO 3744:2009, EN 982:1996+A1:2008, EN ISO 3457:2008 EN ISO 2860:2008, EN ISO 7096:2008, ISO 5006: 2006
-------------------------------------	--

4. Noise level :	
Certain n° :	e13*2000/14*2005/88*0059*08
Date :	2009-06-17
Conformity assessment procedure :	Attachment VIII following the periodical inspection on technical extended with "Information on the scope of delivery" by TÜV Rheinland.
Authorized entity :	Société Nationale de Certification et d'Homologation s.à r.l CE0499 11, route de Luxembourg 5230 Sandweiler Luxemburg
Engine power :	*** kW
Guaranteed sound power level :	*** dB (A)

5. Remarks

Managing Director

Geel, Belgium

//****





CONTENTS

Foreword	0-1	6. Traveling of the machine	4-12
Before servicing this machine	0-2	7. Efficient working method	4-15
EC regulation approved	0-3	8. Operation in the special work sites	4-19
Table to enter S/No and distribution	0-4	9. Normal operation of excavator	4-21
Safety labels	0-5	10. Attachment lowering	4-22
Machine data plate	0-17	11. Storage	4-23
Guide (direction, S/No, symbol)	0-18	12. RCV lever operating pattern	4-25
		13. Switching hydraulic attachment circuit	4-27
SAFETY HINTS			
1. Before operating the machine	1-1	TRANSPORTATION	
2. During operating the machine	1-6	1. Preparation for transportation	5-1
3. During maintenance	1-13	2. Dimension and weight	5-2
4. Parking	1-16	3. Loading the machine	5-4
		4. Fixing the machine	5-6
		5. Loading and unloading by crane	5-7
SPECIFICATIONS			
1. Major components	2-1	MAINTENANCE	
2. Specifications	2-2	1. Instruction	6-1
3. Working range	2-4	2. Tightening torque	6-6
4. Weight	2-5	3. Fuel, coolant and lubricants	6-9
5. Lifting capacities	2-6	4. Maintenance check list	6-11
6. Bucket selection guide	2-8	5. Maintenance chart	6-16
7. Undercarriage	2-10	6. Service instruction	6-18
8. Specification for major components	2-12	7. Electrical system	6-39
9. Recommended oils	2-15	8. Air conditioner and heater	6-42
CONTROL DEVICES			
1. Cab devices	3-1	TROUBLESHOOTING GUIDE	
2. Cluster	3-2	1. Engine	7-1
3. Switches	3-23	2. Electrical system	7-2
4. Levers and pedals	3-27	3. Others	7-3
5. Air conditioner and heater	3-29	HYDRAULIC BREAKER AND QUICK CLAMP	
6. Others	3-36	1. Selecting hydraulic breaker	8-1
OPERATION			
1. Suggestion for new machine	4-1	2. Circuit configuration	8-2
2. Check before starting the engine	4-2	3. Maintenance	8-3
3. Starting and stop the engine	4-3	4. Precaution while operating the breaker	8-4
4. Mode selection system	4-6	5. Quick clamp	8-6
5. Operation of the working device	4-11	INDEX	
			9-1





FOREWORD

This manual contains a number of instructions and safety recommendations regarding driving, handling, lubrication, maintenance, inspection and adjustment of the excavator. The manual is to promote safety maintenance and enhance machine performance.

Keep this manual handy and have all personnel read it periodically.

If you sell the machine, be sure to give this manual to the new owners.

This machine complies with EC directive "2006/42/EC".

1. Read and understand this manual before operating the machine.

This operator's manual may contain attachments and optional equipment that are not available in your area. Please consult your local Hyundai distributor for those items you require.

Improper operation and maintenance of this machine can be hazardous and could result in serious injury or death.

Some actions involved in operation and maintenance of the machine can cause a serious accident, if they are not done in a manner described in this manual.

The procedures and precautions given in this manual apply only to intended uses of the machine. If you use your machine for any unintended uses that are not specifically prohibited, you must be sure that it is safe for you and others. In no event should you or others engage in prohibited uses of actions as described in this manual.

2. Inspect the jobsite and follow the safety recommendations in the safety hints section before operating the machine.

3. Use genuine Hyundai spare parts for the replacement of parts.

We expressly point out that Hyundai will not accept any responsibility for defects resulting from non-genuine parts or non workmanlike repair.

In such cases Hyundai cannot assume liability for any damage.

Continuing improvements in the design of this machine can lead to changes in detail which may not be reflected in this manual. Consult Hyundai or your Hyundai distributor for the latest available information for your machine or for questions regarding information in this manual.



BEFORE SERVICING THIS MACHINE

It is the responsibility of the owner and all service and maintenance personnel to avoid accidents and serious injury by keeping this machine properly maintained.

It also is the responsibility of the owner and all service and maintenance personnel to avoid accidents and serious injury while servicing the machine.

No one should service or attempt to repair this machine without proper training and supervision.

All service and maintenance personnel should be thoroughly familiar with the procedures and precautions contained in this manual.

All personnel also must be aware of any federal, state, provincial or local laws or regulations covering the use and service of construction equipment.

The procedures in this manual do not supersede any requirements imposed by federal, state, provincial or local laws.

Hyundai can not anticipate every possible circumstance or environment in which this machine may be used and serviced.

All personnel must remain alert to potential hazards.

Work within your level of training and skill.

Ask your supervisor if you are uncertain about a particular task. Do not try to do too much too fast.

Use your common sense.



EC REGULATION APPROVED

- Noise level (EN474-1 : 2006 and 2000/14/EC) are as followings.

LWA : 101 dB (EU only)

LPA : 76 dB

- The value of vibrations transmitted by the operator's seat are lower than standard value of (EN474-1 : 2006 and 2002/44/EC)





TABLE TO ENTER SERIAL NO. AND DISTRIBUTOR

Machine Serial No.	
Engine Serial No.	
Manufacturing year	
Manufacturer Address	Hyundai Heavy Industries co., Ltd. 1000, Bangeojinsunhwan-doro, Dong-Ku, Ulsan 682-792, Korea
Distributor for U.S.A Address	Hyundai Heavy Industries U.S.A, Inc 6100 Atlantic Boulevard Norcross GA 30071 U.S.A
Distributor for Europe Address	Hyundai Heavy Industries Europe N. V. Vossendal 11 2240 Geel Belgium
Dealer Address	



SAFETY LABELS

1. LOCATION

Always keep these labels clean. If they are lost or damaged, attach them again or replace them with a new label.

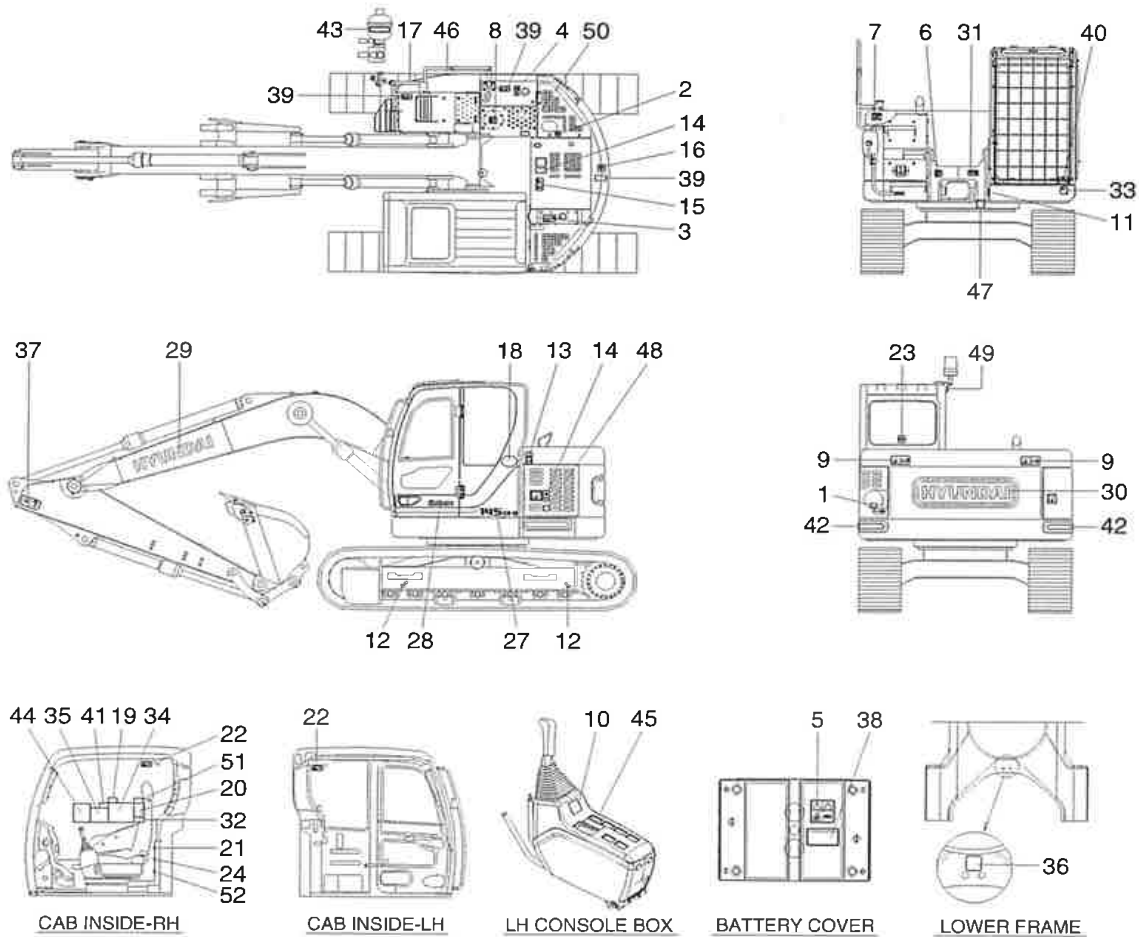

140Z90SL01

- | | | | | | |
|----|----------------------|----|-----------------------------------|----|-------------------------|
| 1 | Air cleaner filter | 18 | Low emission engine | 37 | Keep clear-Boom/arm |
| 2 | Turbocharger cover | 19 | Control ideogram | 38 | Connector |
| 3 | Radiator cap | 20 | Ref operator manual-cab RH pillar | 39 | Falling |
| 4 | Fueling | 21 | Hammer | 40 | FOPS FOG plate |
| 5 | Battery accident | 22 | Safety front window | 41 | Turbocharger |
| 6 | High pressure hose | 23 | Alternate exit | 42 | Reflector |
| 7 | Hydraulic oil level | 24 | Air conditioner filter | 43 | Accumulator |
| 8 | Hydraulic oil lub | 27 | Model name | 44 | Machine control pattern |
| 9 | Keep clear-rear | 28 | Logo (ROBEX) | 45 | Control ideogram-dozer |
| 10 | Console box tilting | 29 | Trade mark (boom) | 46 | RCV lever pattern |
| 11 | Name plate | 30 | Trade mark (CWT) | 47 | Swing bearing |
| 12 | Slinging ideogram | 31 | Reduction gear grease | 48 | Battery position |
| 13 | Keep clear-side | 32 | Clamp-locking | 49 | Beacon lamp |
| 14 | Stay fix | 33 | Noise level (LWA) | 50 | Fuel shut off |
| 15 | Shearing-engine hood | 34 | Service instruction | 51 | Water separator |
| 16 | No step | 35 | Lifting chart | 52 | MCU/ECM connector |
| 17 | Transporting | 36 | Tie | | |

2. DESCRIPTION

There are several specific warning labels on this machine please become familiarized with all warning labels.

Replace any safety label that is damaged, or missing.

1) AIR CLEANER FILTER (item 1)

This warning label is positioned on the air cleaner cover.

- ※ Periodic and proper inspection, cleaning and change of elements prolong engine life time and maintain the good performance of engine.

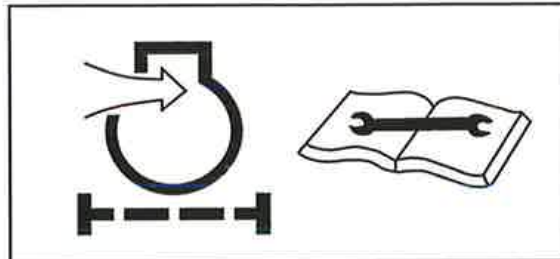

21070FW01

2) TURBOCHARGER COVER (item 2)

This warning label is positioned on the turbocharger cover.

- ▲ Do not touch turbocharger or it may cause severe burn.



21070FW02

3) RADIATOR CAP (item 3)

This warning label is positioned on the radiator.

- ▲ Never open the filler cap while engine running or at high coolant temperature.



14070FW03

4) FUELING (item 4)

This warning label is positioned on the left side of fuel filler neck.

- ▲ Stop the engine when refueling. All lights or flames shall be kept at a safe distance while refueling.

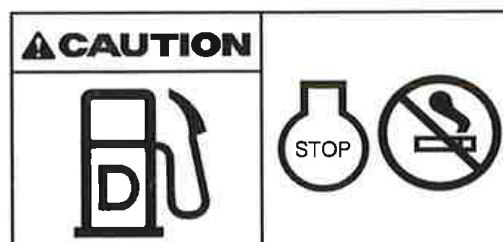

21070FW04

5) BATTERY ACCIDENT (item 5)

This warning label is positioned on the battery cover.

- ▲ Electrolyte containing sulfuric acid cause severe burns. Avoid being in contact with skin, eyes or clothes. In the event of accident flush with sufficient water, call a physician immediately.
- ※ Maintain the electrolyte at the recommended level.
With electrolyte at proper level, less space may cause the gases to be accumulated in the battery.
- ▲ Extinguish all smoking materials and open flames before checking the battery.
- ▲ Do not use matches, lighters or torches as a light source near the battery for the probable presence of explosive gas.
- ▲ Do not allow unauthorized personnel to change the battery or to use booster cables.
- ▲ For safety from electric shock, do not battery terminal with a wet hand.

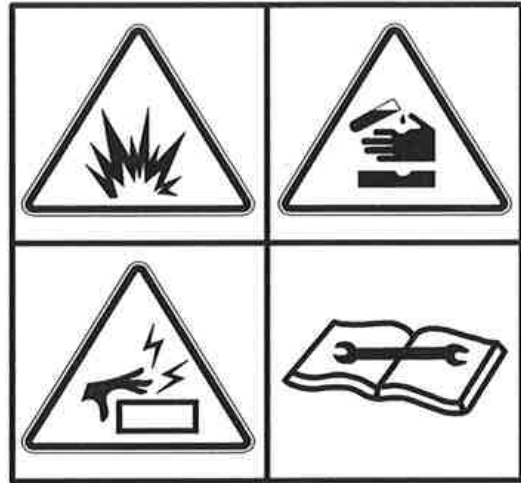

36070FW05

6) HIGH PRESSURE HOSE (item 6)

These warning labels are positioned in the front of upper frame and on the right side of MCV box.

- ▲ Escaping fluid under pressure can penetrate the skin causing serious injury.
- ※ Study the service manual before service job.



14070FW29

7) HYDRAULIC OIL LEVEL (item 7)

This warning label is positioned on the inside of the MCV box.

- ▲ Place the bucket on the ground whenever servicing the hydraulic system.
- ※ Check oil level on the level gauge.
- ※ Refill the recommended hydraulic oil up to specified level if necessary.

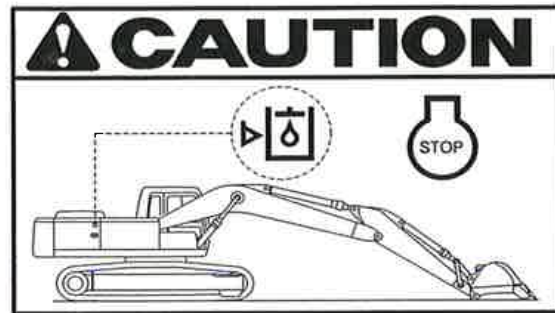

21070FW07

8) HYDRAULIC OIL LUBRICATION (item 8)

This warning label is positioned on the top of the hydraulic tank.

- ※ Do not mix with different brand oils.
- ▲ Never open the filler cap while high temperature.
- ▲ Loosen the cap slowly and release internal pressure completely.



14070FW08

9) REAR KEEP CLEAR (item 9)

This warning label is positioned on the rear of counterweight.

- ▲ To prevent serious personal injury or death keep clear of machine swing radius.
- ▲ Do not deface or remove this label from the machine.

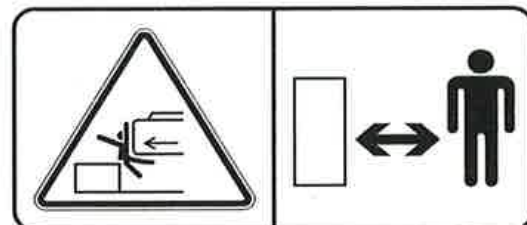

21090FW09

10) CONSOLE BOX TILTING (item 10)

This warning label is positioned on the LH console box.

- ※ Before you get off the machine be sure to tilt the LH console box.

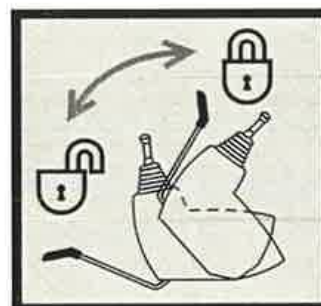

30007A1FW06



11) SIDE KEEP CLEAR (item 13)

This warning labels are positioned on the both side of counterweight.

- ▲ To prevent serious personal injury or death keep clear of machine swing radius.
- ▲ Do not deface or remove this label from the machine.



21070FW13

12) STAY FIX (item 14)

This warning labels are positioned on the both side cover and MCV box.

- ▲ Be sure to support the stay when the door needs to be opened.
- ▲ Be careful that the opened door may be closed by the external or natural force like strong wind.



21070FW14

13) SHEARING-ENGINE HOOD (item 15)

This warning label is positioned on the engine hood.

- ▲ Don't open the engine hood during the engine's running.
- ▲ Don't touch exhaust pipe or it may cause severe burn.

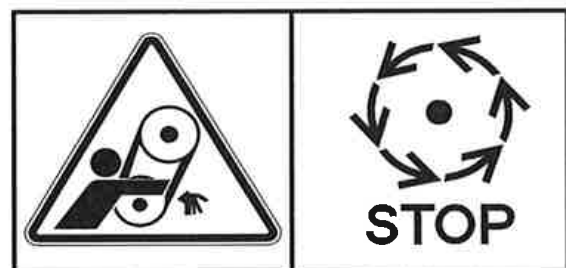

21070FW15



14) NO STEP (item 16)

These warning label is positioned on the counterweight.

- △ Don't step on the engine hood and counterweight.



21070FW16

15) TRANSPORTING (item 17)

This warning label is positioned right side of upper frame.

- ▲ Study the operator's manual before transporting the machine, if provided and tie down arm and track to the carrier with lashing wire.

See page 5-6 for details.



14070FW17

16) CONTROL IDEOGRAM (item 19)

This warning label is positioned in right window of the cab.

- ▲ Check the machine control pattern for conformance to pattern on this label. If not, change label to match pattern before operating machine.

- ▲ Failure to do so could result in injury or death.

See page 4-11 for details.

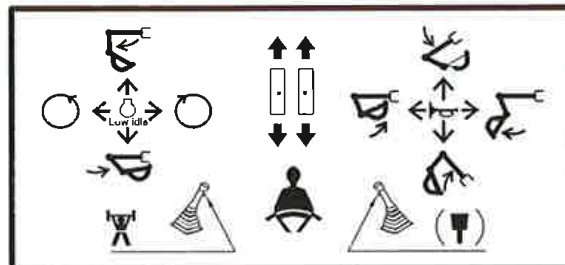

36070FW19

17) REF OPERATOR MANUAL (item 20)

This warning label is positioned on the right side window of the cab.

- ▲ Study the operator's manual before starting and operating machine.

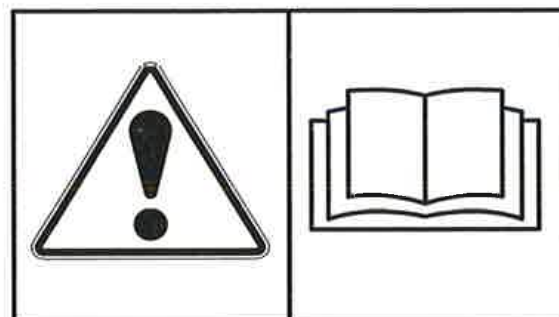

21070FW22

18) MAX HEIGHT (item 20)

This warning label is positioned on the right side window of the cab.

- ⚠ Serious injury or death can result from contact with electric lines.
An electric shock being received by merely coming into the vicinity of an electric lines, the minimum distance should be kept considering the supply voltage as page 1-7.

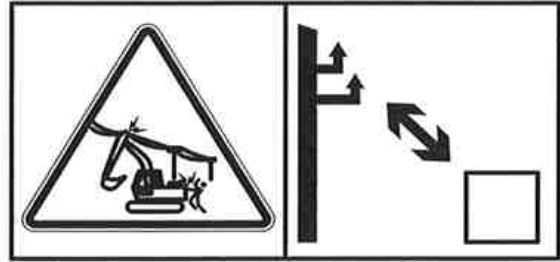

21070FW23

19) INTERFERENCE (item 20)

This warning label is positioned on the right side window of the cab.

- ⚠ Be careful to operate machine equipped with quick clamp or extensions.
- ⚠ Bucket may hit cab or boom, boom cylinders when it reached vicinity of them.

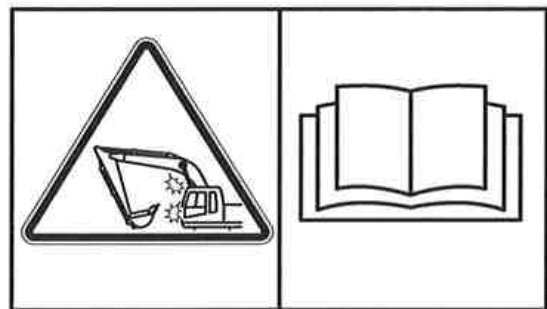

21090FW62

20) SAFETY FRONT WINDOW (item 22)

This warning label is positioned on the both side window of the cab.

- ⚠ Be careful that the front window may be promptly closed.



21070FW24

21) ALTERNATE EXIT (item 23)

This warning label is positioned on the inside of rear window.

- ※ The rear window serves us an alternate exit.
- ※ To remove rear window, pull the ring and push out the glass.



21070FW25



22) AIR CONDITIONER FILTER (item 24)

This warning label is positioned on the air conditioner cover.

- ※ Periodic and proper inspection, cleaning and change of filter prolong air conditioner life time and maintain good performance.

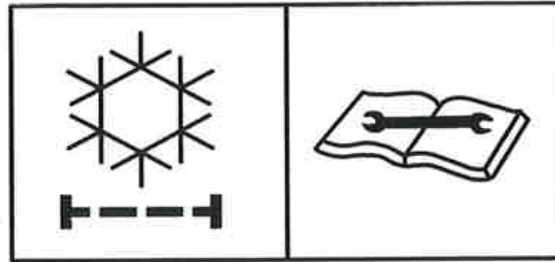

21070FW26

23) REDUCTION GEAR GREASE (item 31)

This warning label is positioned in the front of upper frame.

- ▲ Grease is under high pressure. Grease coming out of the grease plug under pressure can penetrate the body causing injury or death.



21070FW35

24) CLAMP-LOCKING (item 32)

This warning label is positioned on the right side window of cab.

- ▲ Serious injury or death can result from dropping bucket.
- ▲ Operating the machine with quick clamp switch unlocked or without safety pin of moving hook can cause the bucket to drop off.

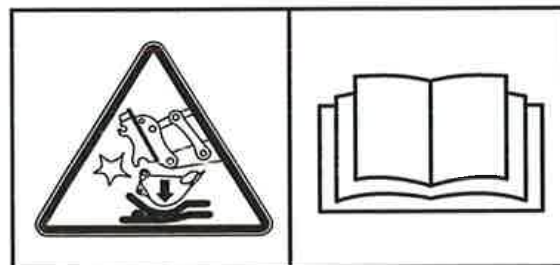

140/0F-W80

25) TIE (item 36)

This warning label is positioned on the lower frame.

- ▲ Make sure no personal are standing close to the tow rope.
- ▲ See page 4-14 for detail.



4507A0FW02



26) KEEP CLEAR-BOOM/ARM (item 37)

This warning label is positioned on both side of the arm.

- ▲ Serious injury or death can result from falling of the attachment.
- ▲ To prevent serious injury or death, keep clear the underneath of attachment.



14070FW31

27) CONNECTOR (item 38)

This warning label is positioned on the battery cover.

- ▲ Before carrying out any electric welding on this machine, follow the below procedure.
 - Pull the connector out of all electric control units.
 - Connector the ground lead of the welding equipment as close to the welding point as possible.
- ※ See page 6-41 for detail.

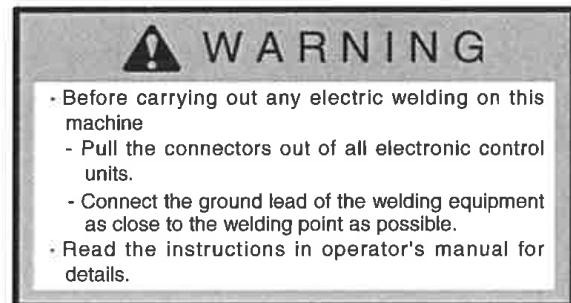

7807AFW20

28) FALLING (item 39)

These warning labels are positioned on the top of the hydraulic tank and counterweight.

- ▲ Falling is one of the major cause of personal injury.
- ▲ Be careful of slippery conditions on the platforms, steps and handrails when standing on the machine.



14070FW30



29) TURBOCHARGER (item 41)

This warning label is positioned on the right window of the cab.

- ▲ In order to prevent turbocharger failure, please allow more than 5 minutes' cool down period (no load low idle operation) before shutting the engine off.

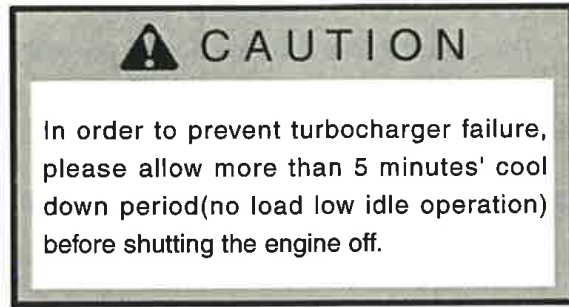

7807AFW20

30) REFLECTOR(item 42)

This warning label is positioned on the rear of counterweight.

- ▲ To prevent serious personal injury or death keep clear of machine swing radius.
- ▲ Do not deface or remove this label from the machine.



140Z90FW70

31) ACCUMULATOR (item 43)

This warning label is positioned on the accumulator of the solenoid valve.

- ※ The accumulator is filled with high pressure nitrogen gas, and it is extremely dangerous if it is handled in the wrong way. Always observe the following precautions.
- ▲ Never make any hole in the accumulator expose it to flame or fire.
- ▲ Do not weld anything to the accumulator.
- ※ When carrying out disassembly or maintenance of the accumulator, or when disposing of the accumulator, it is necessary to release the gas from the accumulator. A special air bleed valve is necessary for this operation, so please contact your Hyundai distributor.



1107A0FW46



32) MACHINE CONTROL PATTERN (item 44)

This warning label is positioned on the right side window of the cab.

- ▲ Check the machine control pattern for conformance to pattern on this label. If not, change label to match pattern before operating machine.
- ▲ Failure to do so could result in injury or death.
- ※ See page 4-26 for details.

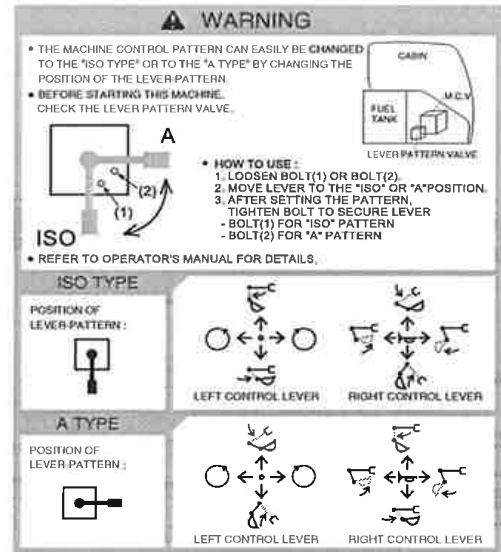

140Z90FW99

33) RCV LEVER PATTERN (item 46)

This warning label is positioned right side of MCV box.

- ※ See page 4-25 for details.

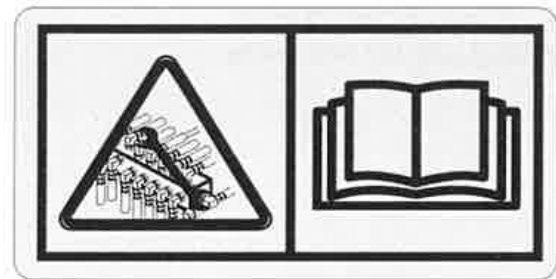

14W90FW47

34) SWING BEARING (item 47)

This warning label is positioned in the front of swing ring gear.

- ※ See page 6-32 for details.

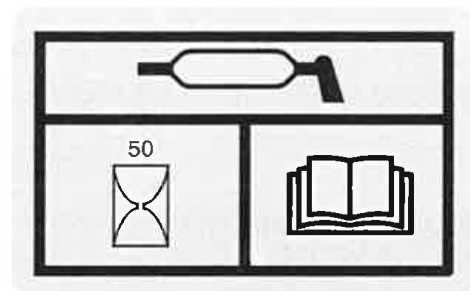

38090FW02

35) BATTERY POSITION (item 48)

This warning label is positioned left side of side door.

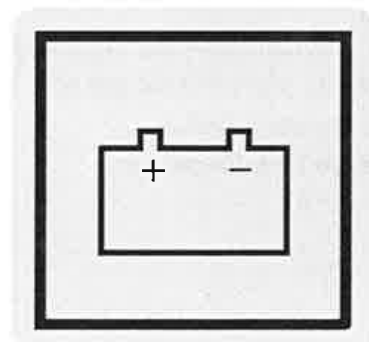

38090FW03

36) BEACON LAMP (item 49)

This warning label is positioned on the right outside of the cabin.

- ※ Make sure the beacon lamp maintains a vertical position.

A horizontal position can result in a decrease in life time of the lamp due to the infiltration of foreign substances such as dust or water.

- ※ While the machine transfer, the beacon lamp is easy to break. In that case, change the position of the lamp to the horizontal.

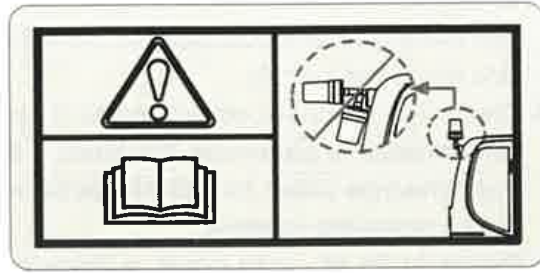

140Z90FW49

37) FUEL SHUT OFF (item 50)

This warning label is positioned on the left side of the hydraulic tank.

- ※ Fill only the hydraulic oil.
- ※ Do not fill the diesel fuel.

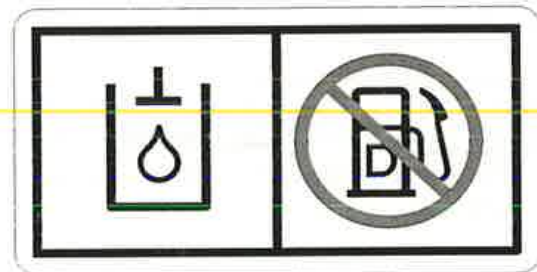

140WH90FW51

38) WATER SEPARATOR (item 51)

This warning label is positioned in right window of the cab.

- ▲ In order to protect high pressure fuel system, please drain water in water separator before starting the engine.



210N90FW50

39) MCU/ECM CONNECTOR (item 52)

This warning label is positioned on the low cover of the air conditioner in the cab.

- ※ MCU communicates the machine data with Laptop computer through RS232 service socket.
- ※ ECM communicates the engine data with Mitsubishi electric tool adapter through J1939 service socket.
- ※ See page 3-48 for details.



235Z90FW52



MACHINE DATA PLATE

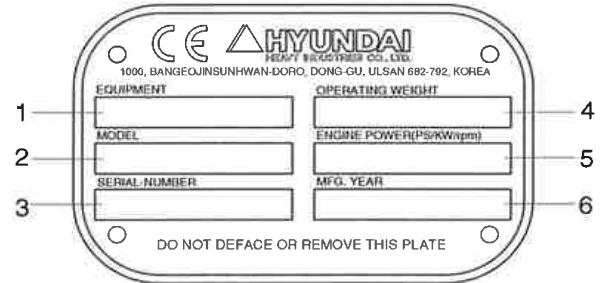
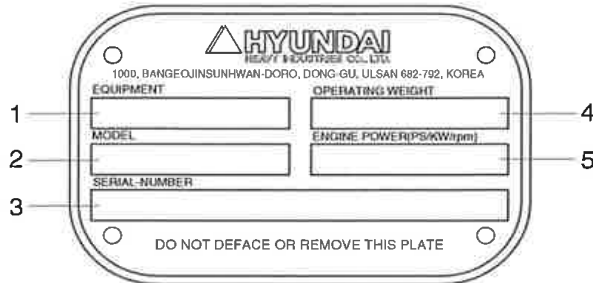

FOR EU ONLY

21090FW10

- | | | | | | |
|---|------------|---|------------------|---|--------------------|
| 1 | Equipment | 3 | Serial number | 5 | Engine power |
| 2 | Model name | 4 | Operating weight | 6 | Manufacturing year |

※ The machine serial number assigned to this particular machine and should be used when requesting information or ordering service parts for this machine from your authorized HYUNDAI dealer. The machine serial number is also stamped on the frame.

GUIDE

1. DIRECTION

The direction of this manual indicate forward, backward, right and left on the standard of operator when the travel motor is in the rear and machine is on the traveling direction.

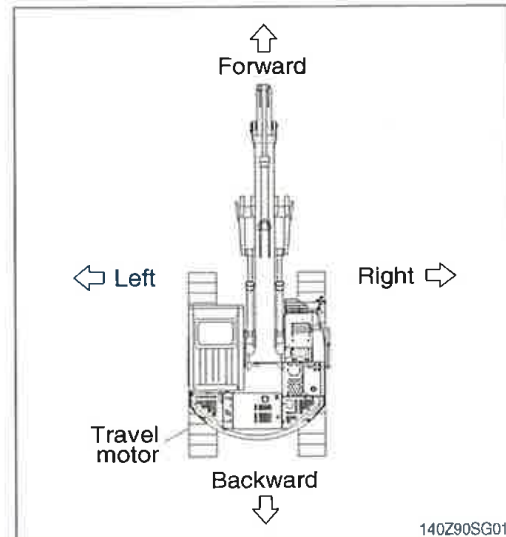

2. SERIAL NUMBER

Inform following when you order parts or the machine is out of order.

1) MACHINE SERIAL NUMBER

The numbers are located below the right window of the operator's cab.



2) ENGINE SERIAL NUMBER

The numbers are located on the engine name plate.

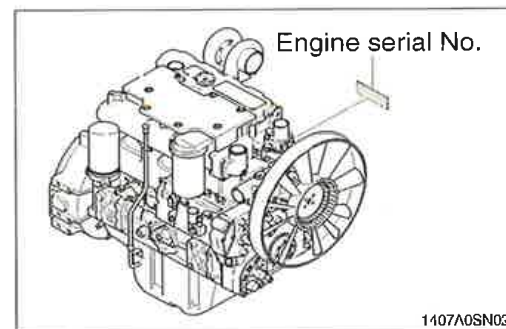

3. INTENDED USE

This machine is designed to be used mainly for the following work.

- Digging work
- Loading work
- Smoothing work
- Ditching work

※ Please refer to the section 4 (efficient working method) further details.

4. SYMBOLS

▲ Important safety hint.

△ It indicates matters which can cause the great loss on the machine or the surroundings.

※ It indicates the useful information for operator.

SAFETY HINTS

1. BEFORE OPERATING THE MACHINE

Think-safety first.

In special situation, wear protective clothing including a safety helmet, safety shoes, gloves, safety glasses and ear protection as required by the job condition.

Almost every accident is caused by disregarding the simple and fundamental safety hints.

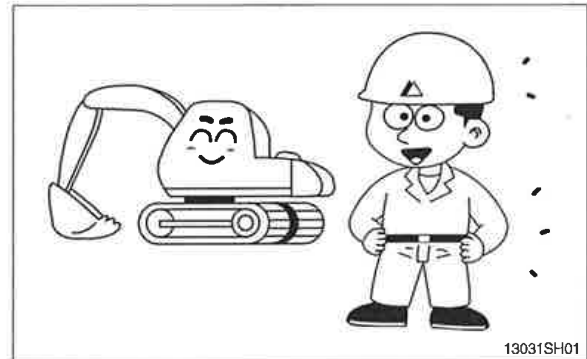

Be sure to understand thoroughly all about the operator's manual before operating the machine.

Proper care is your responsibility.

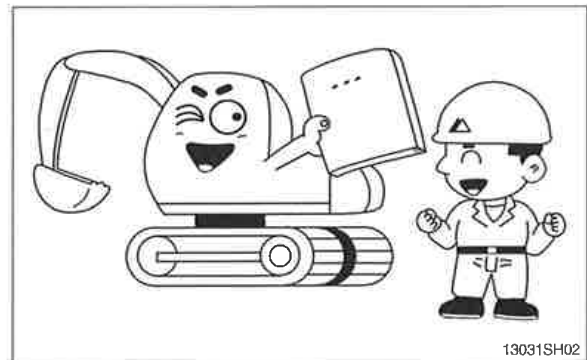

Fully understand the details and process of the construction before starting the work.

If you find anything dangerous on the job, consult with the job supervisor for the preventive measures before operating the machine.

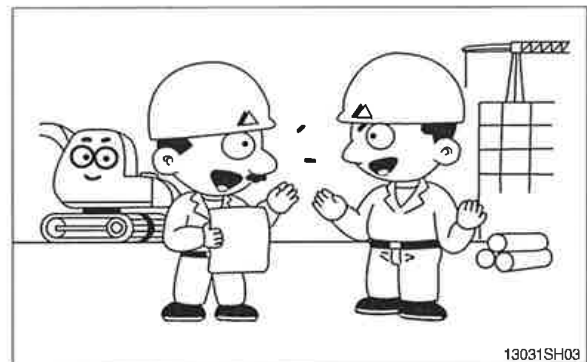

Do not operate when tired, or after drinking alcoholic beverages or any type of drugs.

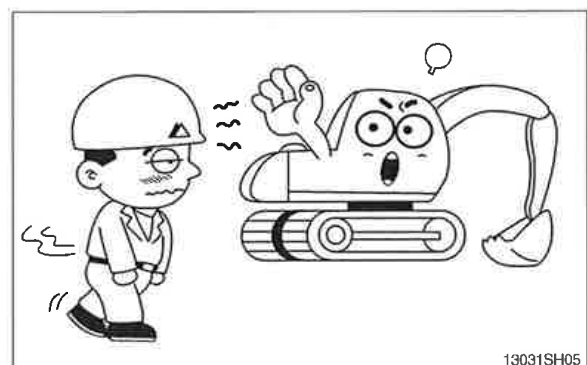

Check daily according to the operation manual.

Repair the damaged parts and tighten the loosened bolts.

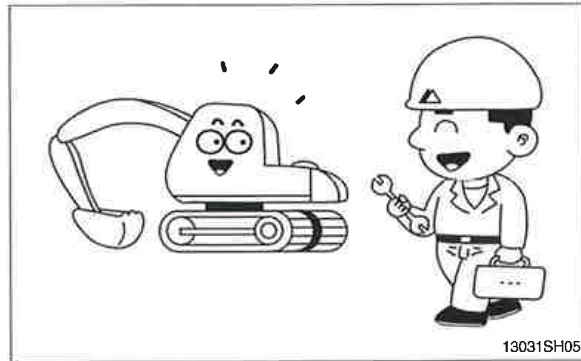

Check for leakage of engine oil, hydraulic oil, fuel and coolant.

Keep machine clean, clean machine regularly.

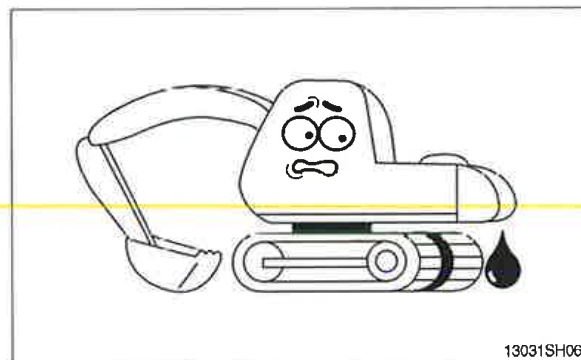

Do not operate the machine if it requires repairs.
Operate after complete repair.

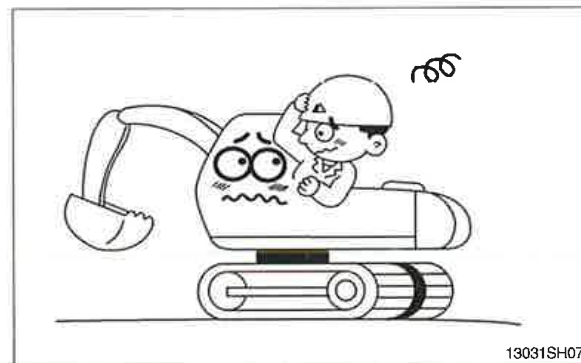

Be prepared if a fire starts.

Keep a fire extinguisher handy and emergency numbers for a fire department near your telephone.



PROTECTION AGAINST FALLING OR FLYING OBJECTS

If there is any danger of falling or flying objects hitting the operator, install protective guards in place to protect the operator as required for each particular situation.

Be sure to close the front window before commencing work.

Make sure to keep all persons other than operator outside the range of falling or flying objects. In case you need top guard, front guard and FOPS (falling object protective structure), please contact Hyundai distributor in Europe.

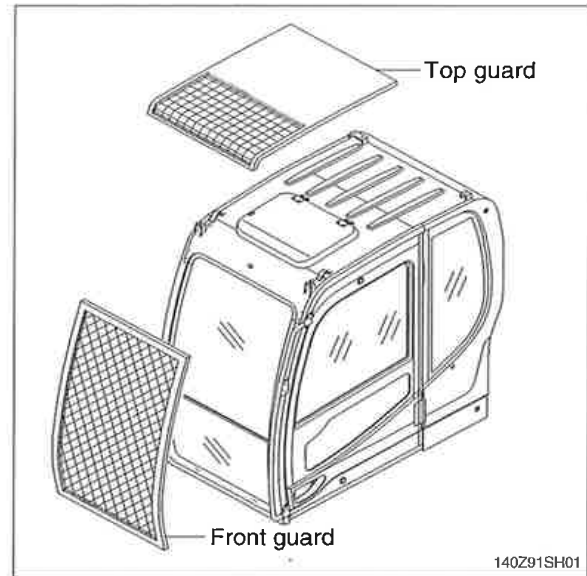

UNAUTHORIZED MODIFICATION

Any modification made without authorization from Hyundai can create hazards.

Before making a modification, consult your Hyundai distributor. Hyundai will not be responsible for any injury or damage caused by any unauthorized modification.

PREPARE FOR EMERGENCY

Only in case of emergency, use the installed hammer for breaking the windshield of the cab, and then exit carefully.

Be sure you know the phone numbers of persons you should contact in case of an emergency.

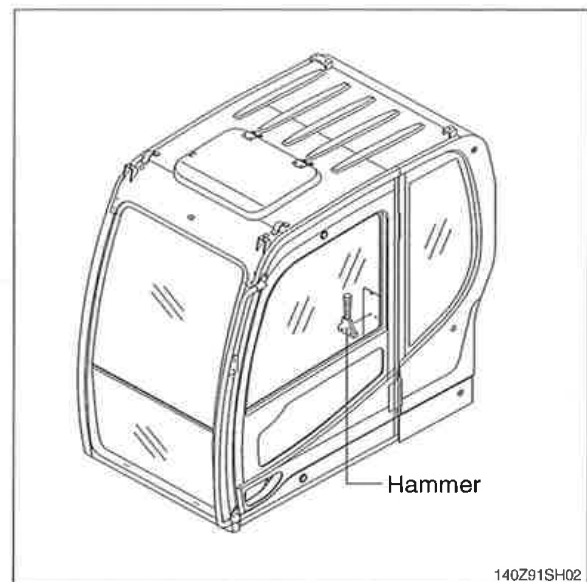

ROTATING BEACON

When you operate a machine on a road or beside a road, a rotating beacon is required to avoid any traffic accident.

Please contact your Hyundai distributor to install it.

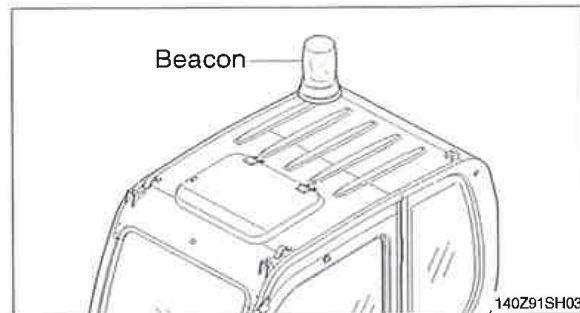

PRECAUTIONS FOR ATTACHMENTS

When installing and using an optional attachment, read the instruction manual for the attachment and the information related to attachments in this manual.

Do not use attachments that are not authorized by Hyundai or your Hyundai distributor. Use of unauthorized attachments could create a safety problem and adversely affect the proper operation and useful life of the machine.

Any injuries, accidents, product failures resulting from the use of unauthorized attachments are not the responsibility of Hyundai.

The stability of this machine is enough to be used for general work. When you operate this machine, allow for the lifting capacity tables. If you want to use other special applications (not covered in this manual), you have to attach additional counterweight or be cautious while running the machine.

SAFETY RULES

Only trained and authorized personnel can operate and maintain the machine.

Follow all safety rules, precautions and instructions when operating or performing maintenance on the machine.

When working with another operator or a person on worksite traffic duty, be sure all personnel understand all hand signals that are to be used.



SAFETY FEATURES

Be sure all guards and covers are in their proper position. Have guards and covers repaired if damaged.

Use safety features such as safety lock and seat belts properly.

Never remove any safety features. **Always** keep them in good operating condition.

Improper use of safety features could result in serious bodily injury or death.

MACHINE CONTROL PATTERN

Check machine control pattern for conformance to pattern on label in cab.

If not, change label to match pattern before operating machine.

Failure to do so could result in injury.

CALIFORNIA PROPOSITION 65

Diesel engine exhaust and some of its constituents are known to the State of California to cause cancer, birth defects and other reproductive harm.

This product contains or emits chemicals known to the State of California to cause cancer or birth defects or other reproductive harm.

Battery posts, terminals and related accessories contain lead and lead compounds.

WASH HANDS AFTER HANDLING



13031SH55

Do not load the machine with the lifting eyes on the counterweight.

⚠ The wrong loading method can result in serious bodily injury or death.

2. DURING OPERATING THE MACHINE

Use the handle and footstep when getting on or off the machine.

Do not jump on or off the machine.

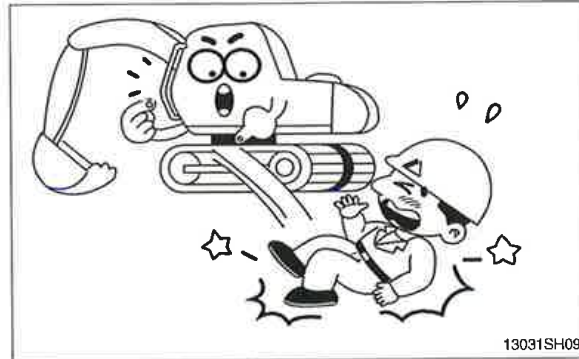

Sound the horn to warn nearby personnel before operating the machine.

Remove all the obstacles like frost on the window before operating the machine for the good visibility.

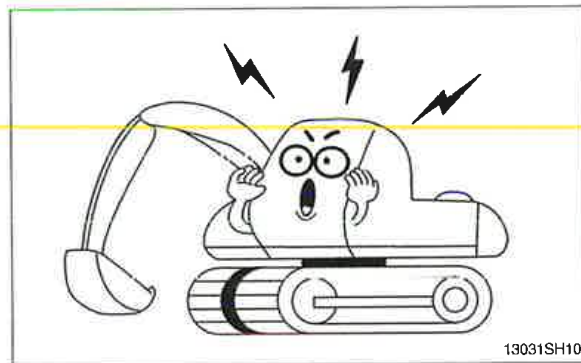

Operate carefully to make sure all personnel or obstacles are clear within the working range of the machine.

Place safety guards if necessary.

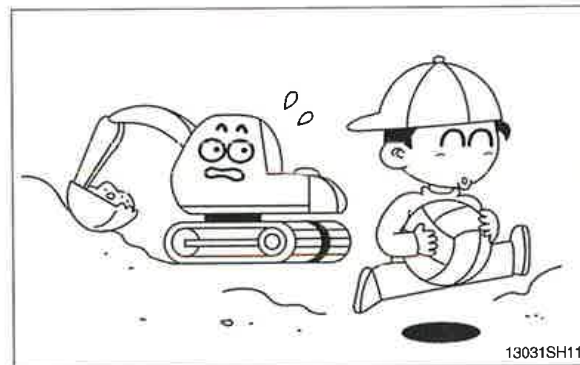

When using the work equipment, pay attention to job site.



Provide proper ventilation when operating engine in a closed area to avoid the danger of exhaust gases.

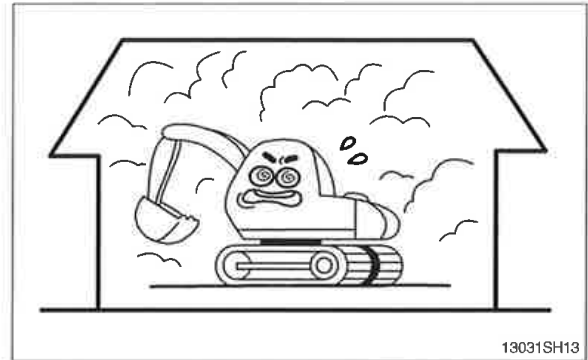

Check the locations of underground gas pipes or water line and secure the safety before operation.

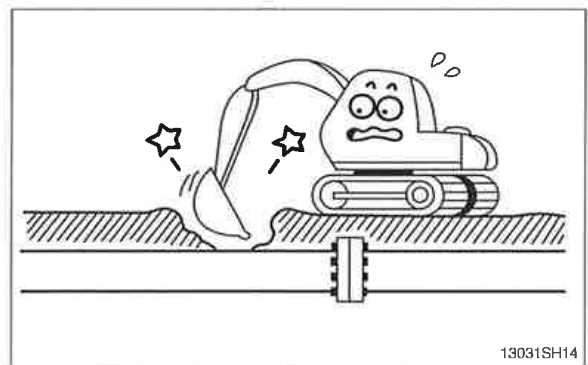

The operating near the electrical lines is very dangerous.
Operate within safe working range permitted as below.

Supply voltage	Min safe separation
6.6 kV	3m (10 ft)
33.0 kV	4m (13 ft)
66.0 kV	5m (16 ft)
154.0 kV	8m (26 ft)
275.0 kV	10m (33 ft)

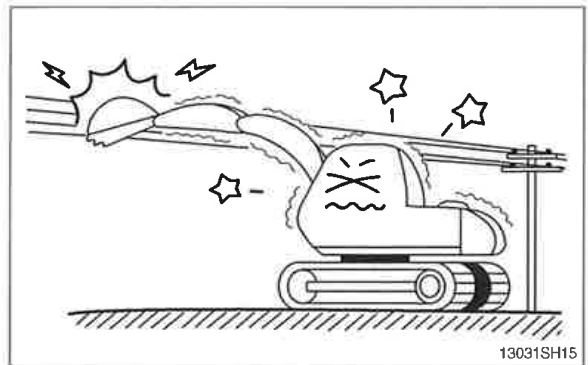

If the machine touches the electric power lines, keep sitting on the operator's seat and make sure the personnel on the ground not to touch the machine until turning off the electric current. Jump off the machine without contacting the machine when you need to get off.

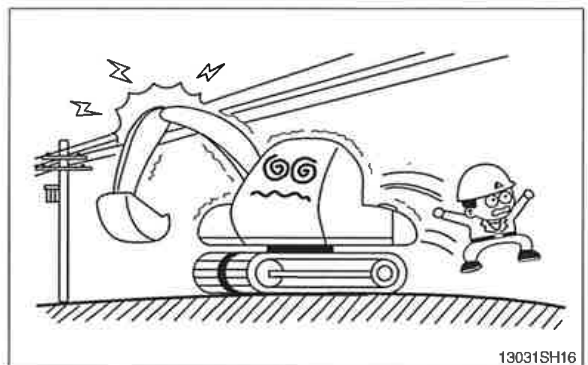

Watch out for obstacles.

Be particularly careful to check the machine clearance during the swing.

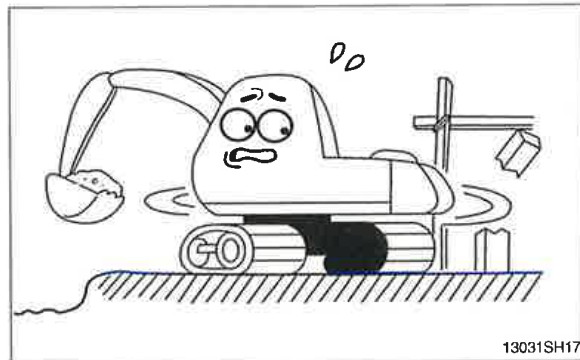

When using the machine as breaker or working in a place where stones may fall down, cab roof guard and head guard should be provided for proper protection.

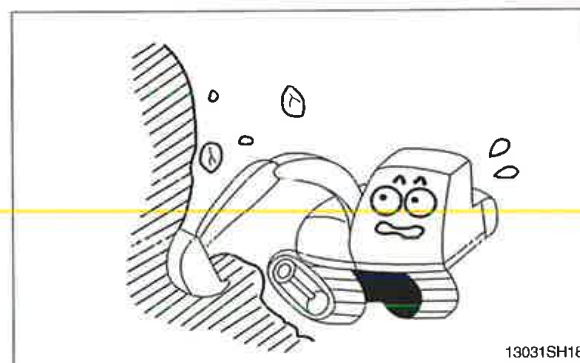

Avoid operating on a cliff or soft ground as there is danger of rolling over.

Make sure to get off easily as keeping the track at a right angle and putting the travel motor into the backward position when working on a cliff or soft ground inevitably.

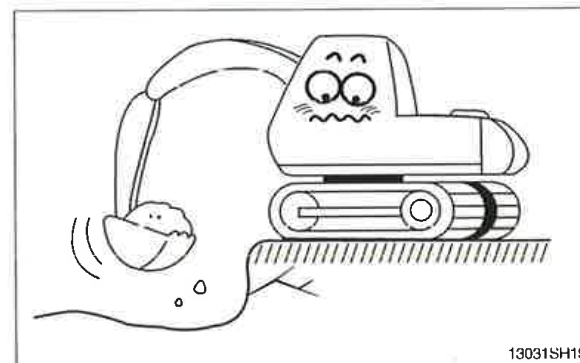

Operate for the lifting work considering the capacity of machine, weight and width of the load.

Be careful not to lift exceeding the machine capacity as it can be the cause of machine damage and safety accident.

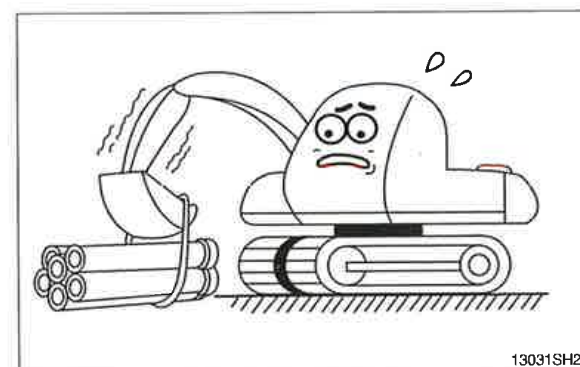

The operation on a slope is dangerous.
Avoid operating the machine on a slope of over 10 degree.

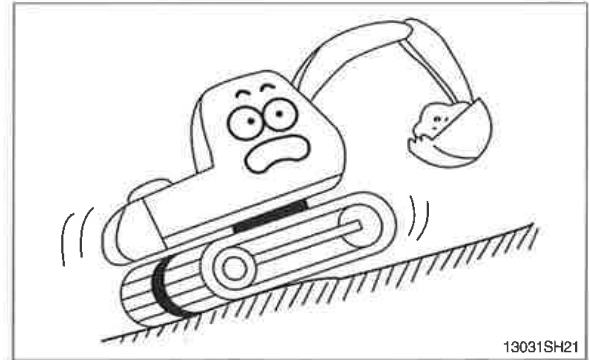

Operate the machine after making ground flat when operation is required on a slope.

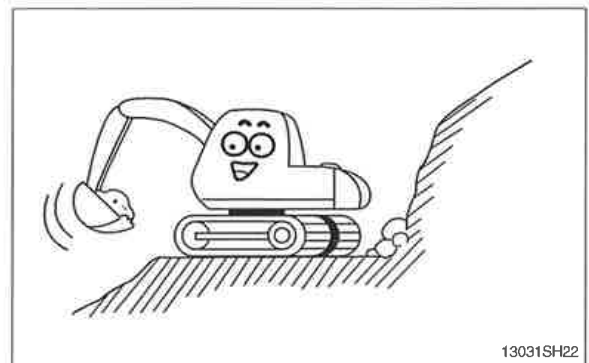

The swing on the slope can be danger of rolling over.
Do not operate to swing the machine with the bucket loaded on a slope since the machine may lose its balance under such an instance.

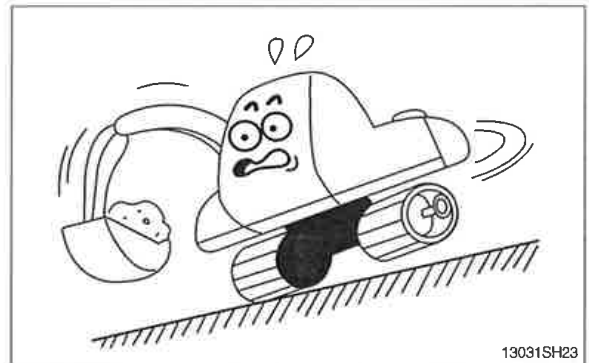

Avoid parking and stopping on a slope.
Lower the bucket to the ground and block the track when parking.

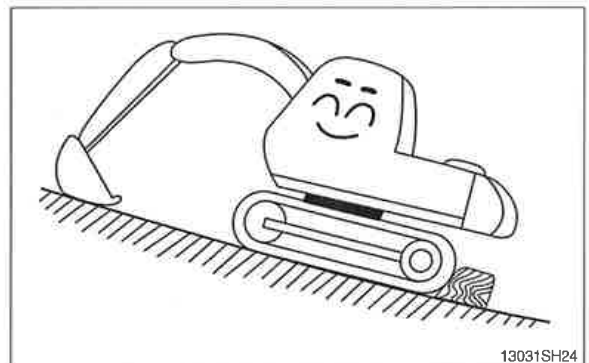

Avoid traveling in a cross direction on a slope as it can cause the danger of rolling over and sliding.

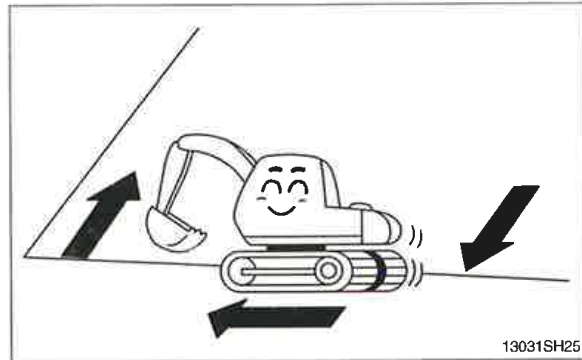

Traveling on a slope is dangerous. Be sure to operate slowly when traveling down a slope and maintain the bucket at a height of 20~30 cm (1 ft) above the ground so that it can be used as brake in an emergency.

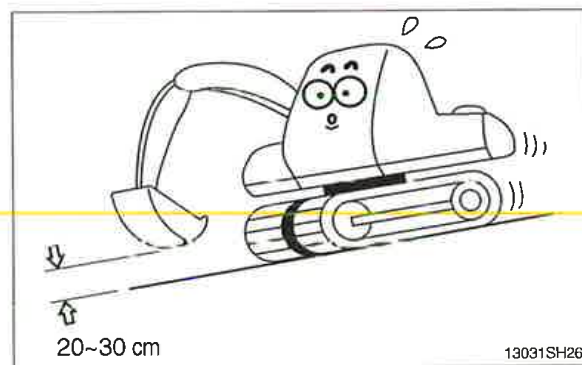

Steering of the machine while traveling on a slope is dangerous. When an inevitable turning of direction is required, turn on the flat and solid ground.

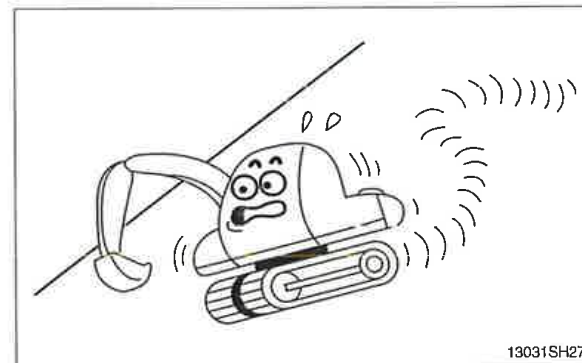

The engine angularity limits are 35 degree. Do not operate by more than the engine limits in any case.

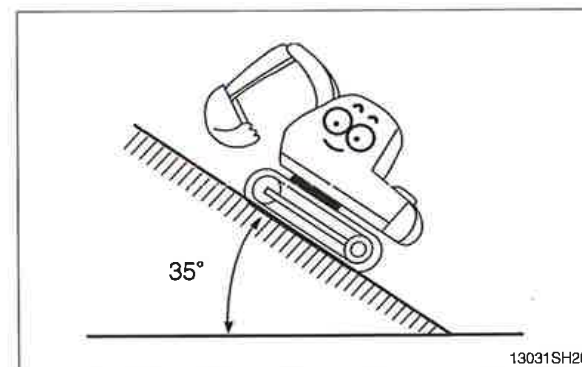

Before traveling the machine, sound the horn to warn nearby personnel.
Operate forward and backward correctly with confirming the location of the travel motor.

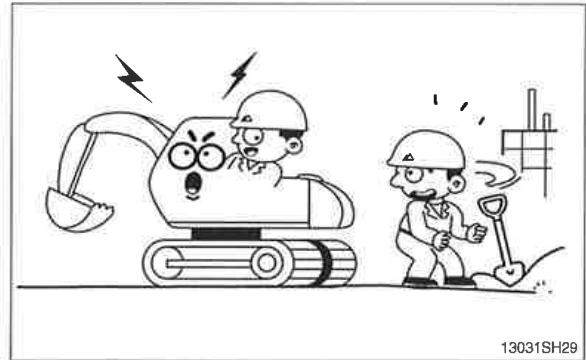

13031SH29

Slow down when traveling through obstacles or uneven ground.

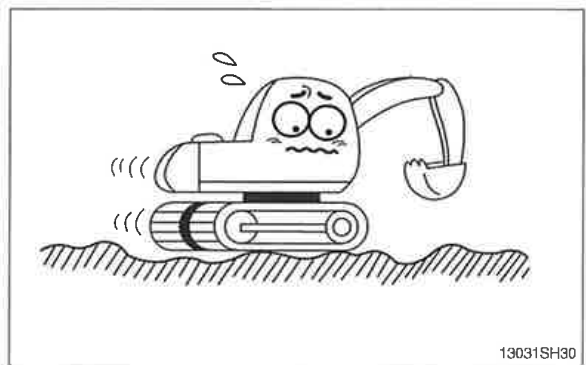

13031SH30

When working on soft ground, place mats or wood boards on the ground to prevent the machine sinking.

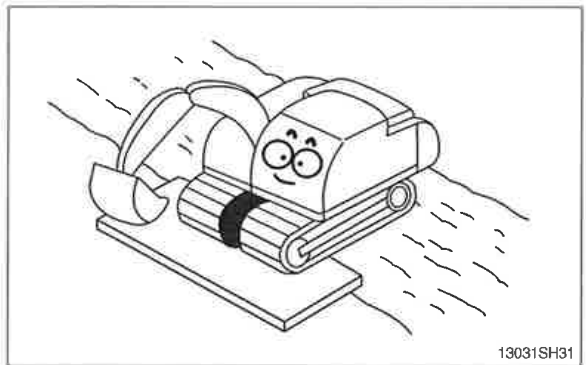

13031SH31

When operating in water or when crossing shallow, check the bed soil condition and depth and flow speed of water, then proceed taking care that water is not above carrier roller.

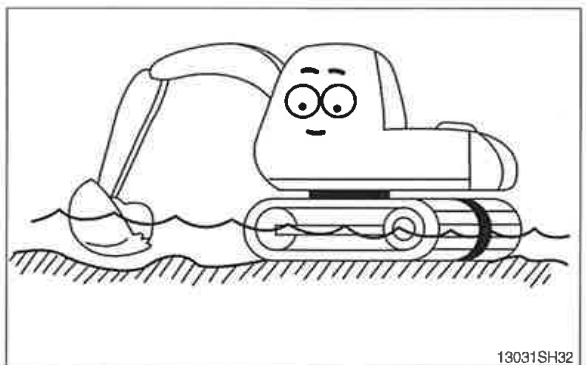

13031SH32

MOUNTING AND DISMOUNTING

Never jump on or off the machine. Never get on or off a moving machine.

When mounting or dismounting, always face the machine and use the handrails, machine or track frame steps, and track shoes. Additional track frame step can be fitted for wider optional shoe. In this case please contact your Hyundai distributor.

Do not hold any control levers when getting on or off the machine.

Ensure safety by always maintaining at least three-point contact of hands and feet with the handrails, steps or track shoes.

Always remove any oil or mud from the handrails, steps and track shoes. If they are damaged, repair them and tighten any loose bolts.

If grasping the door handrail when mounting or dismounting or moving on the track, open and lock the door securely in the open position. Otherwise, the door may move suddenly, causing you to lose balance and fall.

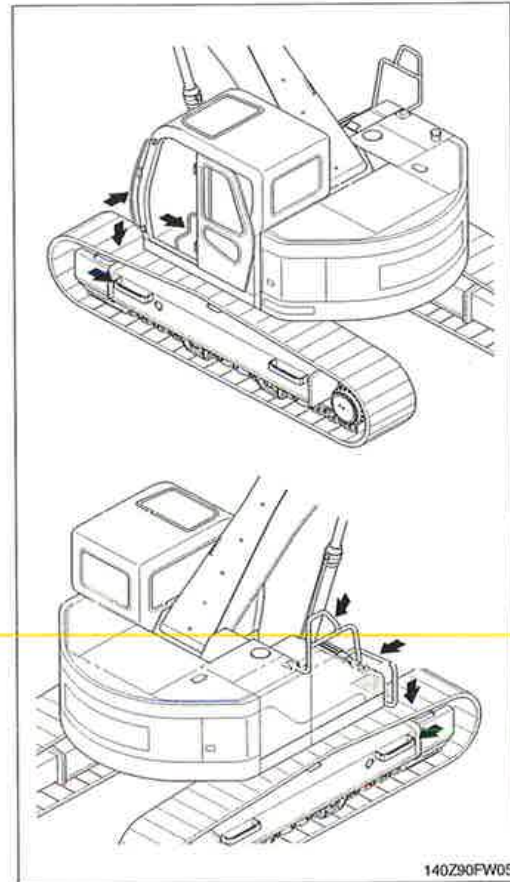

KEEP RIDERS OFF MACHINE

Riders on a machine are subject to injury such as being struck objects and being thrown off the machine.

Only allow the operator on the machine. Keep riders off.

3. DURING MAINTENANCE

Stop the engine immediately when the trouble of the machine is found.
Inspect immediately the cause of trouble such as vibration, overheating and trouble in the cluster then repair.

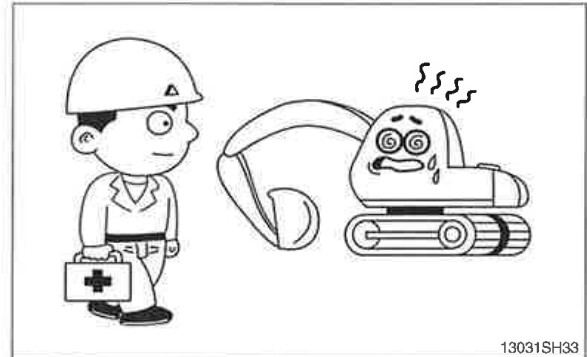

Park on a flat place and stop the engine for inspecting and repairing. Properly TAG machine is not operational. (remove start key)
Extreme care shall be taken during maintenance work. Parts may require additional safe guard.

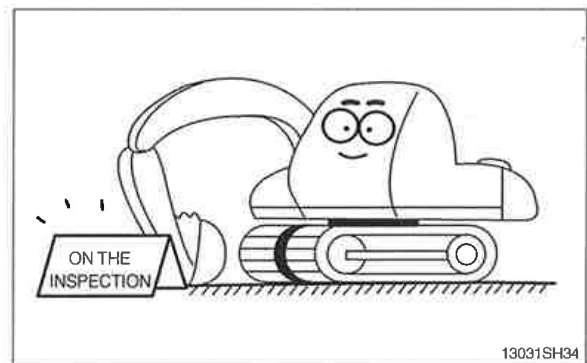

Do not remove the radiator cap from hot engine.
Open the cap after the engine cools, below 50 °C (122 °F) to prevent personal injury from heated coolant spray or steam.



Do not work below the machine.
Be sure to work with proper safety supports.
Do not depend on the hydraulic cylinders to hold up the equipment and attachment.

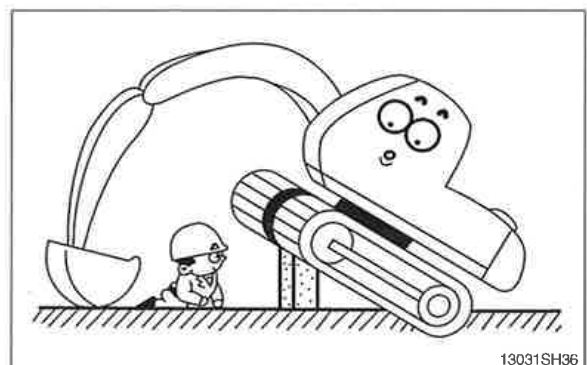

There is the danger of fire in fuel and oil.
Store in cool and dry area, away from any open flames.

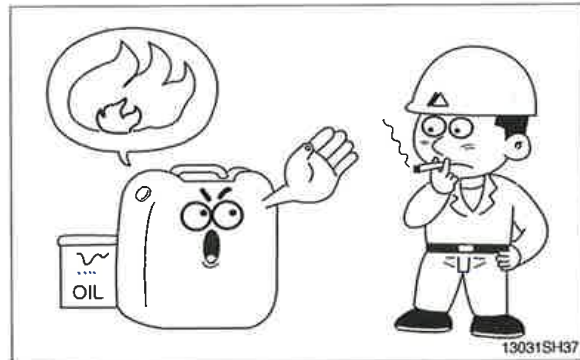

Do not touch exhaust pipe, or may cause severe burn.

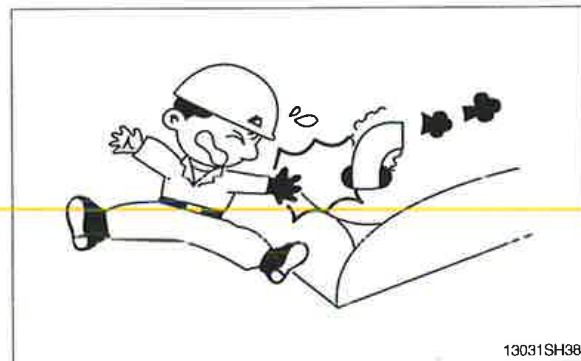

Do not open the engine hood and covers while the engine is running.



Be careful of not hitting the edges when you service engine.

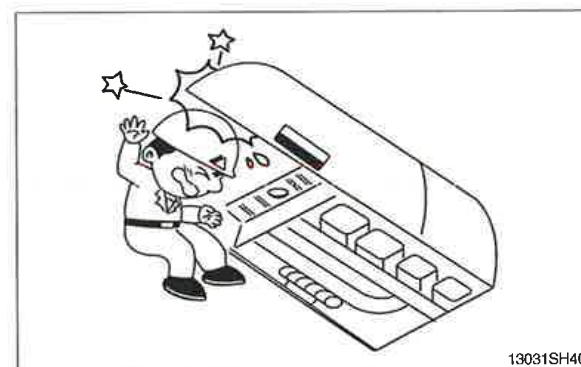



Be careful that the front window may be promptly closed.

Be sure to support stay, when the side door needs to be opened.

Be careful that the open side door may closed by the external or natural force like strong wind.



13031SH41

The antislip protection should be replaced if they have become worn or have been printed over.

Be sure to free of oil, water and grease etc.

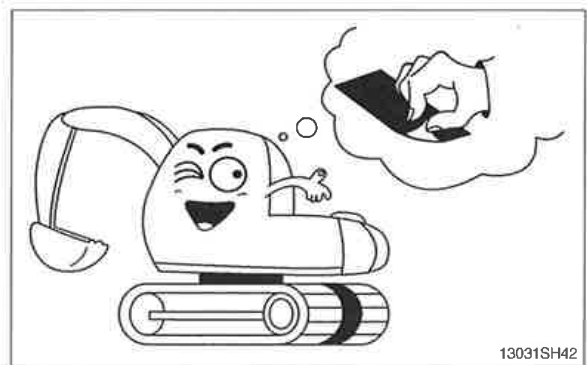

13031SH42

Be careful of not touching slip, fall down etc., when you work at the upper frame to service engine and/or other component.

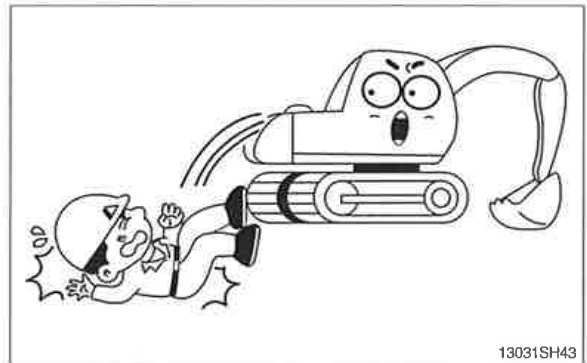

13031SH43

HIGH PRESSURE GAS

Contain high pressure gas.

To avoid explosion and personal injury, do not expose to fire, do not weld, do not drill.

Relieve pressure before discharging.

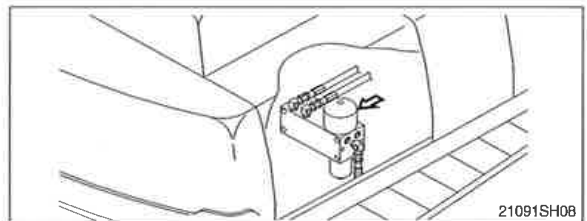

21091SH08

LIFT EYES CAN FAIL

Lift eyes or tank can fail when lifting tank containing fluids resulting in possible personal injury.

Drain tank of all fluids before lifting.

4. PARKING

When leaving the machine after parking, lower the bucket to the ground completely and put the safety lever at parking position then remove the key.
Lock the cab door.

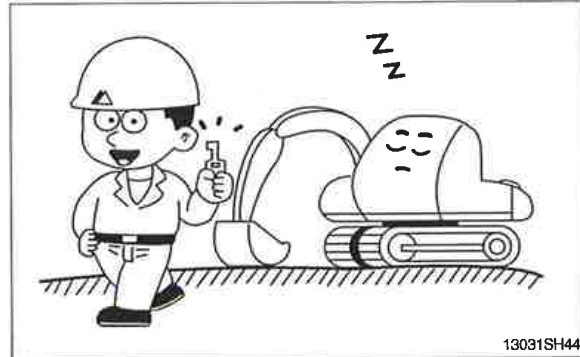

Park the machine in the flat and safe place.

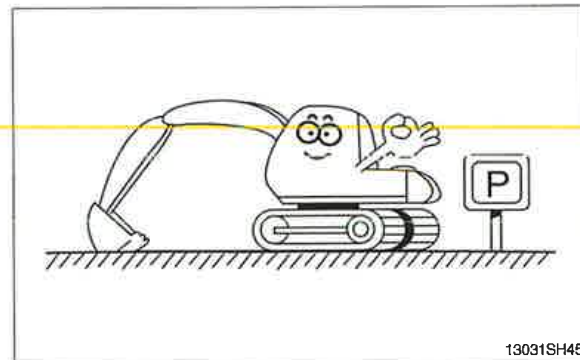

Hope you can work easily and safely observing safety rules.
For safe operation, observe all safety rules.

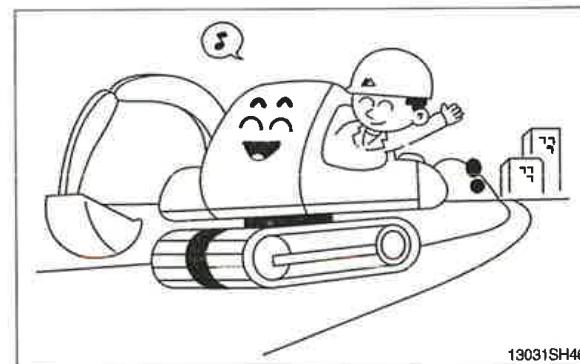

SPECIFICATIONS

1. MAJOR COMPONENT

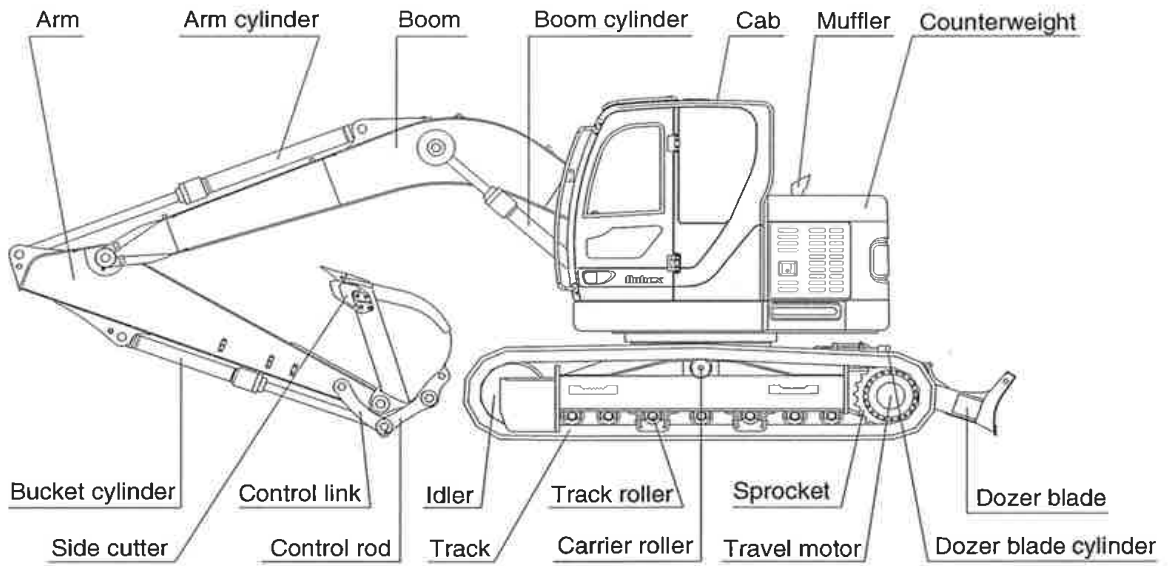
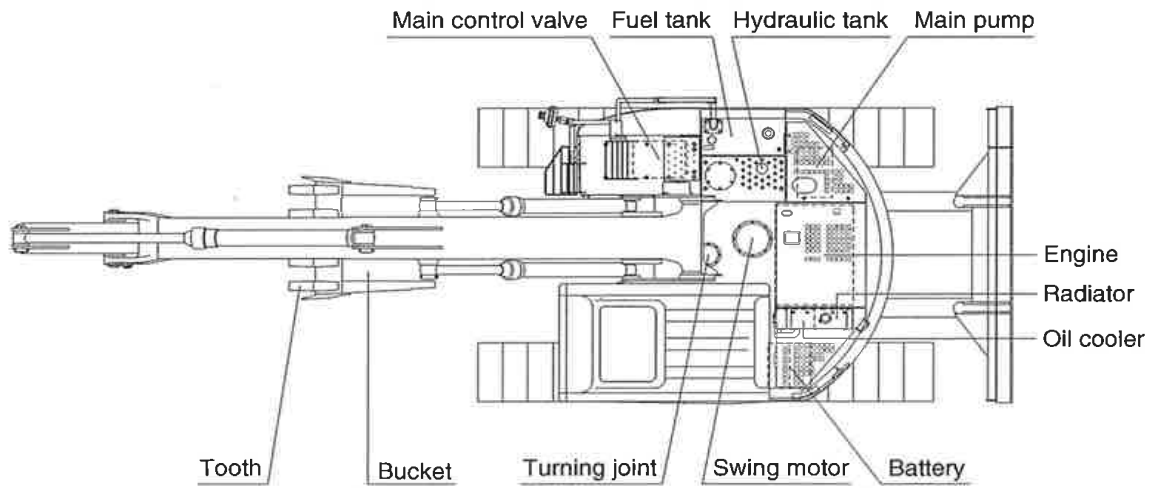

140Z92SP01



2. SPECIFICATIONS

1) R145CR-9

- 4.60 m (15' 1") BOOM and 2.50 m (8' 2") ARM

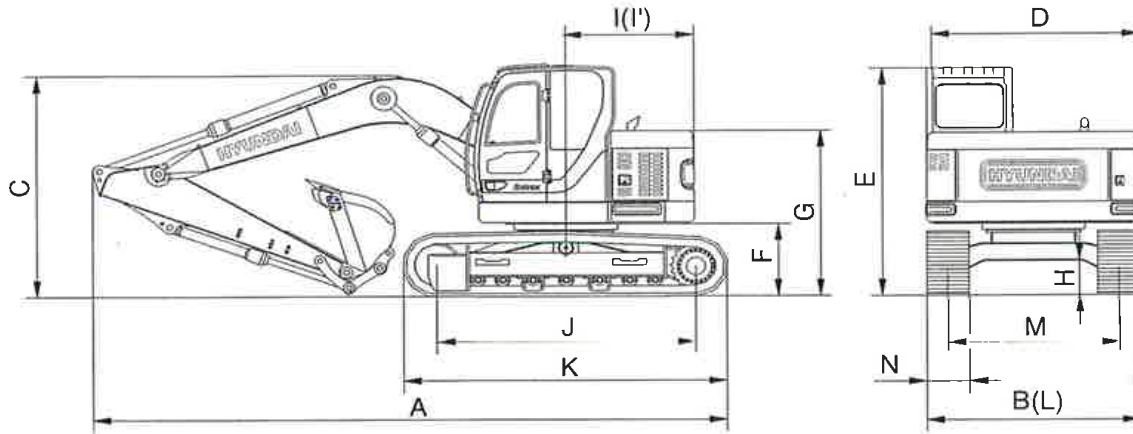

140Z92SF02

Description		Unit	Specification
Operating weight		kg (lb)	14600 (32190)
Bucket capacity (SAE heaped), standard		m ³ (yd ³)	0.52 (0.68)
Overall length	A	mm (ft-in)	7270 (23' 10")
Overall width, with 500 mm shoe	B		2500 (8' 2")
Overall height	C		2860 (9' 5")
Superstructure width	D		2500 (8' 2")
Overall height of cab	E		2900 (9' 6")
Ground clearance of counterweight	F		930 (3' 1")
Engine cover height	G		2065 (6' 9")
Minimum ground clearance	H		440 (1' 5")
Rear-end distance	I		1480 (4' 10")
Rear-end swing radius	I'		1480 (4' 10")
Distance between tumblers	J		2910 (9' 7")
Undercarriage length	K		3640 (11' 11")
Undercarriage width	L		2500 (8' 2")
Track gauge	M		2000 (6' 7")
Track shoe width, standard	N	500 (20")	
Travel speed (low/high)		km/hr (mph)	3.2/5.5 (2.0/3.4)
Swing speed		rpm	12.0
Gradeability		Degree (%)	35 (70)
Ground pressure (500 mm shoe)		kgf/cm ² (psi)	0.46 (6.54)
Max traction force		kg (lb)	13300 (29320)



2) R145CRD-9

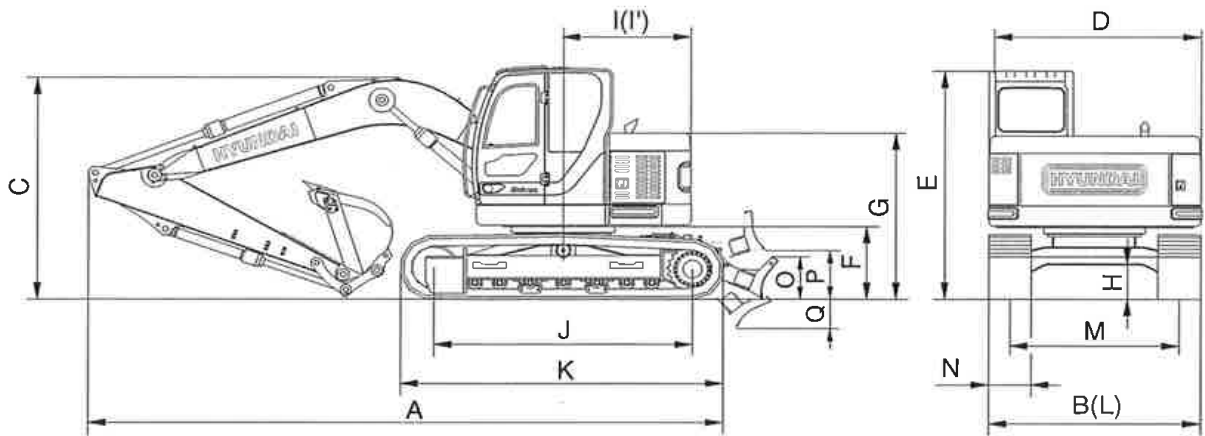

140Z92SP04

Description		Unit	Specification	
Operating weight		kg (lb)	15400 (33950)	
Bucket capacity (SAE heaped), standard		m ³ (yd ³)	0.52 (0.68)	
Overall length	A	mm (ft-in)	7820 (25' 8")	
Overall width, with 500 mm shoe	B		2500 (8' 2")	
Overall height	C		2860 (9' 5")	
Superstructure width	D		2500 (8' 2")	
Overall height of cab	E		2900 (9' 6")	
Ground clearance of counterweight	F		930 (3' 1")	
Engine cover height	G		2065 (6' 9")	
Minimum ground clearance	H		440 (1' 5")	
Rear-end distance	I		1480 (4' 10")	
Rear-end swing radius	I'		1480 (4' 10")	
Distance between tumbler	J		2910 (9' 7")	
Undercarriage length	K		3640 (11' 11")	
Undercarriage width	L		2500 (8' 2")	
Track gauge	M		2000 (6' 7")	
Track shoe width, standard	N		500 (20")	
Height of blade	O		575 (1' 8")	
Ground clearance of blade up	P		420 (1' 8")	
Depth of blade down	Q		430 (1' 6")	
Travel speed (low/high)			km/hr (mph)	3.2/5.5 (2.0/3.4)
Swing speed			rpm	12.0
Gradeability		Degree (%)	35 (70)	
Ground pressure (500 mm shoe)		kgf/cm ² (psi)	0.49 (6.97)	
Max traction force		kg (lb)	13300 (29320)	

3. WORKING RANGE

1) R145CR/CRD-9

(1) 4.60 m (15' 1") MONO BOOM

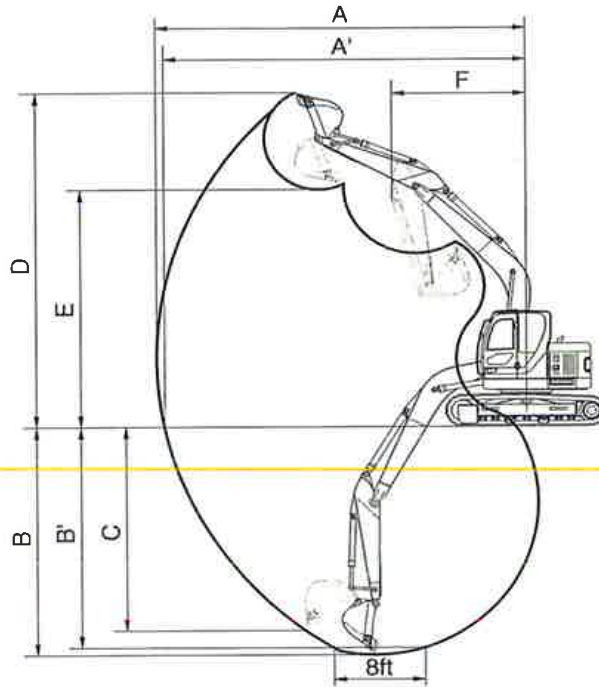

140Z92SP06

Description		1.90 m (6' 3") Arm	2.10 m (6' 11") Arm	※2.50 m (8' 2") Arm	3.00 m (9' 10") Arm
Max digging reach	A	7730 mm (25' 4")	7900 mm (25' 11")	8310 mm (27' 3")	8770 mm (28' 9")
Max digging reach on ground	A'	7580 mm (24' 10")	7750 mm (25' 0")	8170 mm (26' 10")	8630 mm (28' 4")
Max digging depth	B	4890 mm (16' 1")	5100 mm (16' 9")	5500 mm (18' 1")	5990 mm (19' 8")
Max digging depth (8ft level)	B'	4640 mm (15' 3")	4870 mm (16' 0")	5290 mm (17' 4")	5810 mm (19' 1")
Max vertical wall digging depth	C	4400 mm (14' 5")	4600 mm (15' 1")	5000 mm (16' 5")	5400 mm (17' 9")
Max digging height	D	8840 mm (29' 0")	8970 mm (29' 5")	9350 mm (30' 8")	9730 mm (31' 11")
Max dumping height	E	6350 mm (20' 10")	6470 mm (21' 3")	6850 mm (22' 6")	7230 mm (23' 9")
Min swing radius	F	1860 mm (6' 1")	2030 mm (6' 8")	1980 mm (6' 6")	2260 mm (7' 5")
Bucket digging force	SAE	87.3 [94.8] kN	87.3 [94.8] kN	87.3 [94.8] kN	87.3 [94.8] kN
		8900 [9670] kgf	8900 [9670] kgf	8900 [9670] kgf	8900 [9670] kgf
		19620 [21300] lbf	19620 [21300] lbf	19620 [21300] lbf	19620 [21300] lbf
	ISO	102 [110.8] kN	102 [110.8] kN	102 [110.8] kN	102 [110.8] kN
		10400 [11290] kgf	10400 [11290] kgf	10400 [11290] kgf	10400 [11290] kgf
		22930 [24890] lbf	22930 [24890] lbf	22930 [24890] lbf	22930 [24890] lbf
Arm crowd force	SAE	76.5 [83.1] kN	73.6 [79.9] kN	62.8 [68.2] kN	55.9 [60.7] kN
		7800 [8470] kgf	7500 [8140] kgf	6400 [6950] kgf	5700 [6190] kgf
		17200 [18670] lbf	16530 [17950] lbf	14110 [15320] lbf	12570 [13640] lbf
	ISO	80.4 [87.3] kN	77.5 [84.1] kN	65.7 [71.4] kN	57.9 [62.8] kN
		8200 [8900] kgf	7900 [8580] kgf	6700 [7270] kgf	5900 [6410] kgf
		18080 [19630] lbf	17420 [18910] lbf	14770 [16040] lbf	13010 [14120] lbf

※ : STD

[] : Power boost



4. WEIGHT

Item	R145CR-9		R145CRD-9	
	kg	lb	kg	lb
Upper structure assembly	6950	15320	←	
Main frame weld assembly	1315	2900	←	
Engine assembly	420	930	←	
Main pump assembly	90	200	←	
Main control valve assembly	140	310	←	
Swing motor assembly	120	260	←	
Hydraulic oil tank assembly	150	330	←	
Fuel tank assembly	120	260	←	
Counterweight	2800	6170	←	
Cab assembly	450	990	←	
Lower chassis assembly	5230	11530	6030	13290
Track frame weld assembly	1480	3260	1640	3620
Swing bearing	215	470	←	
Travel motor assembly	240	530	←	
Turning joint	50	110	←	
Track recoil spring	105	230	←	
Idler	125	280	←	
Carrier roller	20	45	←	
Track roller	35	80	←	
Track-chain assembly (500 mm standard triple grouser shoe)	910	2010	←	
Dozer blade assembly	-		465	1025
Front attachment assembly (4.6 m boom, 2.5 m arm, 0.52 m³ SAE heaped bucket)	2420	5330	←	
4.6 m boom assembly	830	1830	←	
2.5 m arm assembly	435	960	←	
0.52 m³ SAE heaped bucket	460	1010	←	
Boom cylinder assembly	130	290	←	
Arm cylinder assembly	160	350	←	
Bucket cylinder assembly	100	220	←	
Bucket control rod assembly	90	200	←	
Dozer blade cylinder assembly	-		55	120



5. LIFTING CAPACITIES

1) R145CR-9

(1) 4.60 m (15' 1") boom, 2.50 m (8' 2") arm equipped with 0.52 m³ (SAE heaped) bucket and 500 mm (20") triple grouser shoe and 2800 kg (6170 lb) counterweight.

- : Rating over-front
- : Rating over-side or 360 degree

Load point height		Load radius								At max. reach		Reach m (ft)
		1.5 m (5 ft)		3.0 m (10 ft)		4.5 m (15 ft)		6.0 m (20 ft)		Capacity		
6.0 m (20.0 ft)	kg lb					*2960 *6530	*2960 *6530			2710 5970	1700 3750	6.50 (21.3)
4.5 m (15.0 ft)	kg lb					*3460 *7630	3310 7300	*2670 *5890	1930 4250	2120 4670	1280 2820	7.37 (24.2)
3.0 m (10.0 ft)	kg lb			*6090 *13430	*6090 *13430	*4480 *9880	3090 6810	2990 6590	1850 4080	1870 4120	1090 2400	7.81 (25.6)
1.5 m (5.0 ft)	kg lb			*8480 *18700	5380 11860	4640 10230	2810 6190	2870 6330	1730 3810	1780 3920	1030 2270	7.90 (25.9)
Ground Line	kg lb			9050 19950	4920 10850	4390 9680	2590 5710	2750 6060	1630 3590	1850 4080	1060 2340	7.67 (25.2)
-1.5 m (-5.0 ft)	kg lb	*5850 *12900	*5850 *12900	*8700 *19180	4820 10630	4280 9440	2490 5490	2700 5950	1580 3480	2120 4670	1240 2730	7.07 (23.2)
-3.0 m (-10 ft)	kg lb	*8930 *19690	*8930 *19690	*7030 *15500	4900 10800	4300 9480	2510 5530			*2400 *5290	1700 3750	5.97 (19.6)
-4.5 m (-15.0 ft)	kg lb			*3750 *8270	*3750 *8270							

- Note
1. Lifting capacity are based on SAE J1097 and ISO 10567.
 2. Lifting capacity of the ROBEX series does not exceed 75% of tipping load with the machine on firm, level ground or 87% of full hydraulic capacity.
 3. The load point is a hook located on the back of the bucket.
 4. *indicates load limited by hydraulic capacity.

(2) 4.60 m (15' 1") boom, 1.90 m (6' 3") arm equipped with 0.52 m³ (SAE heaped) bucket and 500 mm (20") triple grouser shoe and 2800 kg (6170 lb) counterweight.

Load point height		Load radius								At max. reach		Reach m (ft)
		1.5 m (5 ft)		3.0 m (10 ft)		4.5 m (15 ft)		6.0 m (20 ft)		Capacity		
6.0 m (20.0 ft)	kg lb					*3270 *7210	*3270 *7210			3360 7410	2130 4700	5.75 (18.9)
4.5 m (15.0 ft)	kg lb			*4960 *10930	*4960 *10930	*4310 *9500	3250 7170			2500 5510	1550 3420	6.73 (22.1)
3.0 m (10.0 ft)	kg lb			*7230 *15940	5970 13160	4900 10800	3050 6720	2980 6570	1850 4080	2170 4780	1310 2890	7.22 (23.7)
1.5 m (5.0 ft)	kg lb			*9120 *20110	5220 11510	4620 10190	2800 6170	2880 6350	1750 3860	2070 4560	1230 2710	7.32 (24.0)
Ground Line	kg lb			*8610 *18980	4970 10560	4430 9770	2640 5820	2800 6170	1680 3700	2170 4780	1290 2840	7.06 (23.2)
-1.5 m (-5.0 ft)	kg lb	*6830 *15060	*6830 *15060	*8140 *17950	4970 10960	4370 9630	2580 5690			2560 5640	1540 3400	6.40 (21.0)
-3.0 m (-10 ft)	kg lb			*6010 *13250	5100 11240	*4100 *9040	2650 5840			*2250 *4960	*2250 *4960	5.12 (16.8)



(3) 4.60 m (15' 1") boom, 3.0 m (9' 10") arm equipped with 0.52 m³ (SAE heaped) bucket and 700 mm (20") triple grouser shoe and 2800 kg (6170 lb) counterweight.

Load point height		Load radius										At max. reach		
		1.5 m (5 ft)		3.0 m (10 ft)		4.5 m (15 ft)		6.0 m (20 ft)		7.0 m (25 ft)		Capacity		Reach
														m (ft)
6.0 m	kg					*2560	*2560	*1730	*1730			2350	1450	7.07
(20.0 ft)	lb					*5640	*5640	*3810	*3810			5180	3200	(23.2)
4.5 m	kg					*2760	*2760	*2550	1980			1890	1120	7.86
(15.0 ft)	lb					*6080	*6080	*5620	4370			4170	2470	(25.8)
3.0 m	kg			*3690	*3690	*3690	3170	3030	1880	*1430	1180	1680	960	8.27
(10.0 ft)	lb			*8140	*8140	*8140	6990	6680	4140	*3150	2600	3700	2120	(27.1)
1.5 m	kg			*7740	5620	4720	2880	2890	1750	1950	1130	1610	910	8.36
(5.0 ft)	lb			*17060	12390	10410	6350	6370	3860	4300	2490	3550	2010	(27.4)
Ground	kg			9180	5020	4440	2630	2760	1630	*1830	1080	1660	930	8.14
Line	lb			20240	11070	9790	5800	6080	3590	*4030	2380	3660	2050	(26.7)
-1.5 m	kg	*5380	*5380	8930	4820	4280	2490	2680	1560			1860	1060	7.59
(-5.0 ft)	lb	*11860	*11860	19690	10630	9440	5490	5910	3440			4100	2340	(24.9)
-3.0 m	kg	*7860	*7860	*7790	4830	4250	2460	2680	1560			2380	1400	6.59
(-10 ft)	lb	*17330	*17330	*17170	10650	9370	5420	5910	3440			5250	3090	(21.6)
-4.5 m	kg	*8050	*8050	*5160	5020	*3260	2580							
(-15 ft)	lb	*17750	*17750	*11380	11070	*7190	5690							



2) R145CRD-9 (with dozer blade)

(1) 4.60 m (15' 1") boom, 2.50 m (8' 2") arm equipped with 0.52 m³ (SAE heaped) bucket and 500 mm (20") triple grouser shoe and 2800 kg (6170 lb) counterweight with dozer blade.

• : Rating over-front • : Rating over-side or 360 degree

Load point height		Load radius								At max. reach		
		1.5 m (5 ft)		3.0 m (10 ft)		4.5 m (15 ft)		6.0 m (20 ft)		Capacity		Reach m (ft)
6.0 m (20.0 ft)	kg lb					*2960 *6530	*2960 *6530			*2910 *6420	1820 4010	6.50 (21.3)
4.5 m (15.0 ft)	kg lb					*3460 *7630	*3460 *7630	*2670 *5890	2060 4540	2340 5160	1380 3040	7.37 (24.2)
3.0 m (10.0 ft)	kg lb			*6090 *13430	*6090 *13430	*4480 *9880	3280 7230	3270 7210	1980 4370	2070 4560	1190 2620	7.81 (25.6)
1.5 m (5.0 ft)	kg lb			*8480 *18700	5720 12610	5060 11160	3000 6610	3150 6940	1860 4100	1980 4370	1120 2470	7.90 (25.9)
Ground Line	kg lb			*9170 *20220	5260 11600	4810 10600	2780 6130	3030 6680	1760 3880	2060 4540	1160 2560	7.67 (25.2)
-1.5 m (-5.0 ft)	kg lb	*5850 *12900	*5850 *12900	*8700 *19180	5160 11380	4700 10360	2680 5910	2980 6570	1710 3770	2350 5180	1340 2950	7.07 (23.2)
-3.0 m (-10 ft)	kg lb	*8930 *19690	*8930 *19690	*7030 *15500	5230 11530	4720 10410	2700 5950			*2400 *5290	1830 4030	5.97 (19.6)
-4.5 m (-15.0 ft)	kg lb			*3750 *8270	*3750 *8270							

- Note
1. Lifting capacity are based on SAE J1097 and ISO 10567.
 2. Lifting capacity of the ROBEX series does not exceed 75% of tipping load with the machine on firm, level ground or 87% of full hydraulic capacity.
 3. The load point is a hook located on the back of the bucket.
 4. *indicates load limited by hydraulic capacity.

(2) 4.60 m (15' 1") boom, 3.0 m (9' 10") arm equipped with 0.52 m³ (SAE heaped) bucket and 700 mm (20") triple grouser shoe and 2800 kg (6170 lb) counterweight with dozer blade.

Load point height		Load radius									At max. reach			
		1.5 m (5 ft)		3.0 m (10 ft)		4.5 m (15 ft)		6.0 m (20 ft)		7.0 m (25 ft)		Capacity		Reach m (ft)
6.0 m (20.0 ft)	kg lb					*2560 *5640	*2560 *5640	*1730 *3810	*1730 *3810			2570 5670	1560 3440	7.07 (23.2)
4.5 m (15.0 ft)	kg lb					*2760 *6080	*2760 *6080	*2550 *5620	2110 4650			2090 4610	1220 2690	7.86 (25.8)
3.0 m (10.0 ft)	kg lb			*3690 *8140	*3690 *8140	*3690 *8140	3360 7410	*3210 *7080	2020 4450	*1430 *3150	1280 2820	1860 4100	1050 2310	8.27 (27.1)
1.5 m (5.0 ft)	kg lb			*7740 *17060	5950 13120	*5030 *11090	3070 6770	3170 6990	1890 4170	*1990 *4390	1230 2710	1790 3590	990 2180	8.36 (27.4)
Ground Line	kg lb			*9190 *20260	5360 11820	4850 10690	2820 6220	3040 6700	1770 3900	*1830 *4030	1180 2600	1850 4080	1020 2250	8.14 (26.7)
-1.5 m (-5.0 ft)	kg lb	*5380 *11860	*5380 *11860	*9060 *19970	5160 11380	4700 10360	2680 5910	2960 6530	1690 3730			2070 4560	1160 2560	7.59 (24.9)
-3.0 m (-10 ft)	kg lb	*7860 *17330	*7860 *17330	*7790 *17170	5170 11400	4670 10300	2650 5840	2960 6530	1690 3730			*2460 *5420	1520 3350	6.59 (21.6)
-4.5 m (-15 ft)	kg lb	*8050 *17750	*8050 *17750	*5160 *11380	*5160 *11380	3260 7190	2770 6110							



3) R145LCR-9

(1) 4.60 m (15' 1") boom, 2.50 m (8' 2") arm equipped with 0.52 m³ (SAE heaped) bucket and 500 mm (20") triple grouser shoe and 2800 kg (6170 lb) counterweight.



Load point height		Load radius								At max. reach		
		1.5 m (5 ft)		3.0 m (10 ft)		4.5 m (15 ft)		6.0 m (20 ft)		Capacity		Reach m (ft)
6.0 m (20.0 ft)	kg lb					*2960 *6530	*2960 *6530			2870 6330	1710 3770	6.50 (21.3)
4.5 m (15.0 ft)	kg lb					*3460 *7630	3340 7360	*2670 *5890	1950 4300	2250 4960	1300 2870	7.37 (24.2)
3.0 m (10.0 ft)	kg lb			*6090 *13430	*6090 *13430	*4480 *9880	3120 6880	3170 6990	1870 4120	1990 4390	1110 2450	7.81 (25.6)
1.5 m (5.0 ft)	kg lb			*8480 *18700	5420 11950	4930 10870	2840 6260	3040 6700	1750 3860	1900 4190	1040 2290	7.90 (25.9)
Ground Line	kg lb			*9170 *20220	4970 10960	4680 10320	2620 5780	2930 6460	1650 3640	1970 4340	1080 2380	7.67 (25.2)
-1.5 m (-5.0 ft)	kg lb	*5850 *12900	*5850 *12900	*8700 *19180	4870 10740	4570 10080	2520 5560	2870 6330	1600 3530	2260 4980	1250 2760	7.07 (23.2)
-3.0 m (-10 ft)	kg lb	*8930 *19690	*8930 *19690	*7030 *15500	4940 10890	4590 10120	2540 5600			*2400 *5290	1720 3790	5.97 (19.6)
-4.5 m (-15 ft)	kg lb			*3750 *8270	*3750 *8270							



6. BUCKET SELECTION GUIDE

1) R145CR-9, R145CRD-9

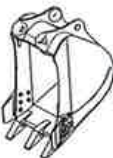
(1) General bucket

		
0.23 m ³ SAE heaped bucket	0.40, 0.46 m ³ SAE heaped bucket	0.52, 0.58, 0.65, 0.71 m ³ SAE heaped bucket

Capacity		Width		Weight	Recommendation			
					4.6 m (15' 1") boom			
SAE heaped	CECE heaped	Without side cutter	With side cutter		1.9 m arm (6' 3")	2.1 m arm (6' 11")	2.5 m arm (8' 2")	3.0 m arm (9' 10")
0.23 m ³ (0.30 yd ³)	0.20 m ³ (0.26 yd ³)	520 mm (20.5")	620 mm (24.4")	335 kg (740 lb)				
0.40 m ³ (0.52 yd ³)	0.35 m ³ (0.46 yd ³)	750 mm (29.5")	850 mm (33.5")	410 kg (900 lb)				
0.46 m ³ (0.60 yd ³)	0.40 m ³ (0.52 yd ³)	840 mm (33.1")	940 mm (37.0")	435 kg (960 lb)				
0.52 m ³ (0.68 yd ³)	0.45 m ³ (0.59 yd ³)	915 mm (36.0")	1015 mm (40.0")	460 kg (1010 lb)				
0.58 m ³ (0.76 yd ³)	0.50 m ³ (0.65 yd ³)	1000 mm (39.4")	1100 mm (43.3")	480 kg (1060 lb)				
0.65 m ³ (0.85 yd ³)	0.55 m ³ (0.72 yd ³)	1105 mm (43.5")	1205 mm (47.4")	500 kg (1100 lb)				
0.71 m ³ (0.93 yd ³)	0.60 m ³ (0.78 yd ³)	1190 mm (46.9")	1290 mm (50.8")	540 kg (1190 lb)				

- Applicable for materials with density of 2000 kg/m³ (3370 lb/yd³) or less
- Applicable for materials with density of 1600 kg/m³ (2700 lb/yd³) or less
- Applicable for materials with density of 1100 kg/m³ (1850 lb/yd³) or less

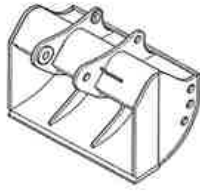
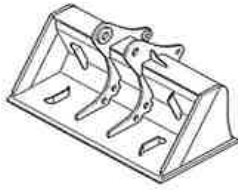

(2) Special bucket

<p>Ditch cleaning bucket</p> 	<p>Slope finishing bucket</p> 
<p>★0.45 m³ SAE heaped bucket</p>	<p>◎0.55 m³ SAE heaped bucket</p>

Capacity		Width		Weight	Recommendation			
SAE heaped	CECE heaped	Without side cutter	With side cutter		4.6 m (15' 1") boom			
					1.9 m arm (6' 3")	2.1 m arm (6' 11")	2.5 m arm (8' 2")	3.0 m arm (9' 10")
★0.45 m ³ (0.59 yd ³)	0.40 m ³ (0.52 yd ³)	1520 mm (59.8")	-	410 kg (900 lb)				
◎0.55 m ³ (0.72 yd ³)	0.45 m ³ (0.59 yd ³)	1800 mm (70.9")	-	585 kg (1290 lb)				

★ : Ditch cleaning bucket

◎ : Slope finishing bucket

- Applicable for materials with density of 2000 kgf/m³ (3370 lbf/yd³) or less
- Applicable for materials with density of 1600 kgf/m³ (2700 lbf/yd³) or less
- Applicable for materials with density of 1100 kgf/m³ (1850 lbf/yd³) or less



7. UNDERCARRIAGE

1) TRACKS

X-leg type center frame is integrally welded with reinforced box-section track frames. The design includes dry tracks, lubricated rollers, idlers, sprockets, hydraulic track adjusters with shock absorbing springs and assembled track-type tractor shoes with triple grousers.

2) TYPES OF SHOES

Model	Shapes		Triple grouser		
R145CR-9	Shoe width	mm (in)	※ 500 (20)	600 (24)	700 (28)
	Operating weight	kg (lb)	14600/32190	14790 (32610)	15020 (33110)
	Ground pressure	kgf/cm ² (psi)	0.46 (6.54)	0.39 (5.55)	0.34 (4.83)
	Overall width	mm (ft-in)	2500 (8' 2")	2600 (8' 6")	2700 (8' 10")
R145CRD-9	Shoe width	mm (in)	※ 500 (20)	600 (24)	700 (28)
	Operating weight	kg (lb)	15400 (33950)	15610 (34610)	15840 (34920)
	Ground pressure	kgf/cm ² (psi)	0.49 (6.97)	0.41 (5.83)	0.36 (5.12)
	Overall width	mm (ft-in)	2500 (8' 2")	2600 (8' 6")	2700 (8' 10")
R145LCR-9	Shoe width	mm (in)	※ 500 (20)	600 (24)	700 (28)
	Operating weight	kg (lb)	14660 (32320)	14850 (32740)	15080 (33250)
	Ground pressure	kgf/cm ² (psi)	0.47 (6.68)	0.39 (5.55)	0.34 (4.83)
	Overall width	mm (ft-in)	2500 (8' 2")	2600 (8' 6")	2700 (8' 10")

※ : Standard

3) NUMBER OF ROLLERS AND SHOES ON EACH SIDE

Item	Quantity	
	R145CR-9/R145CRD-9	R145LCR-9
Carrier rollers	1 EA	1 EA
Track rollers	7 EA	7 EA
Track shoes	45 EA	46 EA



4) SELECTION OF TRACK SHOE

Suitable track shoes should be selected according to operating conditions.

Method of selecting shoes

Confirm the category from the list of applications in table 2, then use table 1 to select the shoe. Wide shoes (Categories B and C) have limitations on applications. Before using wide shoes, check the precautions, then investigate and study the operating conditions to confirm if these shoes are suitable.

Select the narrowest shoe possible to meet the required flotation and ground pressure. Application of wider shoes than recommendations will cause unexpected problem such as bending of shoes, crack of link, breakage of pin, loosening of shoe bolts and the other various problems.

※ Table 1

Track shoe	Specification	Category
500 mm triple grouser	Standard	A
600 mm triple grouser	Option	A
700 mm triple grouser	Option	B

※ Table 2

Category	Applications	Applications
A	Rocky ground, river beds, normal soil	<ul style="list-style-type: none"> Travel at low speed on rough ground with large obstacles such as boulders or fallen trees
B	Normal soil, soft ground	<ul style="list-style-type: none"> These shoes cannot be used on rough ground with large obstacles such as boulders or fallen trees Travel at high speed only on flat ground Travel slowly at low speed if it is impossible to avoid going over obstacles



8. SPECIFICATIONS FOR MAJOR COMPONENTS

1) ENGINE

Item	Specification
Model	Mitsubishi D04FD-TAA
Type	4-cycle turbocharged charge air cooled diesel engine
Cooling method	Water cooling
Number of cylinders and arrangement	4 cylinders, in-line
Firing order	1-3-4-2
Combustion chamber type	Direct injection type
Cylinder bore × stroke	102 × 130 mm
Piston displacement	4250cc (260cu in)
Compression ratio	16.5 : 1
Rated gross horse power (SAE J1995)	119 Hp (89 kW) at 2000 rpm
Maximum torque	45.4 kgf · m (328 lbf · ft) at 1700 rpm
Engine oil quantity	17.5 l (4.6 U.S. gal)
Dry weight	420 kg (930 lb)
High idling speed	2100 ± 50 rpm
Low idling speed	800 ± 100 rpm
Rated fuel consumption	165 g/Hp · hr at 2000 rpm
Starting motor	24 V-5.0 kW
Alternator	24 V-50 A
Battery	2 × 12 V × 80 Ah

2) MAIN PUMP

Item	Specification
Type	Variable displacement tandem axis piston pumps
Capacity	2 × 65 cc/rev
Maximum pressure	350 kgf/cm ² (4980 psi) [380 kgf/cm ² (5400 psi)]
Rated oil flow	2 × 130 l /min (34.3 U.S. gpm / 28.6 U.K. gpm)
Rated speed	2000 rpm

[]: Power boost



3) GEAR PUMP

Item	Specification
Type	Fixed displacement gear pump single stage
Capacity	15cc/rev
Maximum pressure	40 kgf/cm ² (570 psi)
Rated oil flow	30 l /min (7.9 U.S. gpm / 6.6 U.K. gpm)

4) MAIN CONTROL VALVE

Item	Specification
Type	11 spools
Operating method	Hydraulic pilot system
Main relief valve pressure	350 kgf/cm ² (4980 psi) [380 kgf/cm ² (5400 psi)]
Overload relief valve pressure	400 kgf/cm ² (5690 psi)

[]: Power boost

5) SWING MOTOR

Item	Specification
Type	Fixed displacement axial piston motor
Capacity	72 cc/rev
Relief pressure	285 kgf/cm ² (4053 psi)
Braking system	Automatic, spring applied hydraulic released
Braking torque	25 kgf · m (181 lbf · ft)
Brake release pressure	15~50 kgf/cm ² (213~711 psi)
Reduction gear type	2 - stage planetary

6) TRAVEL MOTOR

Item	Specification
Type	Variable displacement axial piston motor
Relief pressure	350 kgf/cm ² (4970 psi)
Capacity (max / min)	77/45 cc/rev
Reduction gear type	2-stage planetary
Braking system	Automatic, spring applied hydraulic released
Brake release pressure	9.5 kgf/cm ² (135 psi)
Braking torque	19.7 kgf · m (280.2 lbf · ft)



7) CYLINDER

Item		Specification
Boom cylinder	Bore dia × Rod dia × Stroke	∅ 105 × ∅ 75 × 1105 mm
	Cushion	Extend only
Arm cylinder	Bore dia × Rod dia × Stroke	∅ 115 × ∅ 80 × 1138 mm
	Cushion	Extend and retract
Bucket cylinder	Bore dia × Rod dia × Stroke	∅ 100 × ∅ 70 × 840 mm
	Cushion	Extend only
Dozer cylinder (option)	Bore dia × Rod dia × Stroke	∅ 100 × ∅ 70 × 250 mm
	Cushion	-

※ Discoloration of cylinder rod can occur when the friction reduction additive of lubrication oil spreads on the rod surface.

※ Discoloration does not cause any harmful effect on the cylinder performance.

8) SHOE

Item		Width	Ground pressure	Link quantity	Overall width
R145CR-9	Standard	500 mm (20")	0.46 kgf/cm ² (6.54 psi)	45	2500 mm (8' 2")
	Option	600 mm (24")	0.39 kgf/cm ² (5.55 psi)	45	2600 mm (8' 6")
		700 mm (28")	0.34 kgf/cm ² (4.83 psi)	45	2700 mm (8' 10")
R145CRD-9	Standard	500 mm (20")	0.49 kgf/cm ² (6.97 psi)	45	2500 mm (8' 2")
	Option	600 mm (24")	0.41 kgf/cm ² (5.81 psi)	45	2600 mm (8' 6")
		700 mm (28")	0.36 kgf/cm ² (5.12 psi)	45	2700 mm (8' 10")
R145LCR-9	Standard	500 mm (20")	0.47 kgf/cm ² (6.68 psi)	46	2500 mm (8' 2")
	Option	600 mm (24")	0.39 kgf/cm ² (5.55 psi)	46	2600 mm (8' 6")
		700 mm (28")	0.34 kgf/cm ² (4.83 psi)	46	2700 mm (8' 10")

BUCKET

Item	Capacity		Tooth quantity	Width	
	SAE heaped	CECE heaped		Without side cutter	With side cutter
R145CR-9	0.52 m ³ (0.68 yd ³)	0.45 m ³ (0.59 yd ³)	5	915 mm (36.0")	1015 mm (40.0")
	0.23 m ³ (0.30 yd ³)	0.20 m ³ (0.26 yd ³)	3	520 mm (20.5")	620 mm (24.4")
	0.40 m ³ (0.52 yd ³)	0.35 m ³ (0.46 yd ³)	4	750 mm (29.5")	850 mm (33.5")
	0.46 m ³ (0.60 yd ³)	0.40 m ³ (0.52 yd ³)	4	840 mm (33.1")	940 mm (37.0")
	0.58 m ³ (0.76 yd ³)	0.50 m ³ (0.65 yd ³)	5	1000 mm (39.4")	1100 mm (43.3")
	0.65 m ³ (0.85 yd ³)	0.55 m ³ (0.72 yd ³)	5	1105 mm (43.5")	1205 mm (47.4")
	0.71 m ³ (0.93 yd ³)	0.60 m ³ (0.78 yd ³)	5	1190 mm (46.9")	1290 mm (50.8")
	★0.45 m ³ (0.59 yd ³)	0.40 m ³ (0.52 yd ³)	-	1520 mm (59.8")	-
	◎0.55 m ³ (0.72 yd ³)	0.45 m ³ (0.59 yd ³)	-	1800 mm (70.9")	-

★ : Ditch cleaning bucket

◎ : Slope finishing bucket



9. RECOMMENDED OILS

Use only oils listed below or equivalent.
Do not mix different brand oil.

Service point	Kind of fluid	Capacity l (U.S. gal)	Ambient temperature °C (°F)								
			-20 (-4)	-10 (14)	0 (32)	10 (50)	20 (68)	30 (86)	40 (104)		
Engine oil pan	Engine oil	17.5 (4.6)					SAE 30				
			SAE 10W								
			SAE 10W-30								
			SAE 15W-40								
Swing drive	Grease	0.35 (0.09)	NLGI NO.1								
			NLGI NO.2								
Swing drive	Gear oil	2.5 (0.7)	SAE 85W-140								
Final drive		1.8 × 2 (0.48 × 2)									
Hydraulic tank	Hydraulic oil	Tank: 96 (25.4) System: 180 (47.6)	ISO VG 32								
			ISO VG 46								
			ISO VG 68								
Fuel tank	Diesel fuel	232 (61.3)	ASTM D975 NO.1								
			ASTM D975 NO.2								
Fitting (Grease nipple)	Grease	As required	NLGI NO.1								
			NLGI NO.2								
Radiator (Reservoir tank)	Mixture of antifreeze and water 50 : 50	15.5 (4.1)	Ethylene glycol base permanent type								

SAE : Society of Automotive Engineers
 API : American Petroleum Institute
 ISO : International Organization for Standardization
 NLGI : National Lubricating Grease Institute
 ASTM : American Society of Testing and Material



CONTROL DEVICES

1. CAB DEVICES

1) The ergonomically designed console box and suspension type seat provide the operator with comfort.

2) ELECTRONIC MONITOR SYSTEM

(1) The centralized electronic monitor system allows the status and conditions of the machine to be monitored at a glance.

(2) It is equipped with a safety warning system for early detection of machine malfunction.

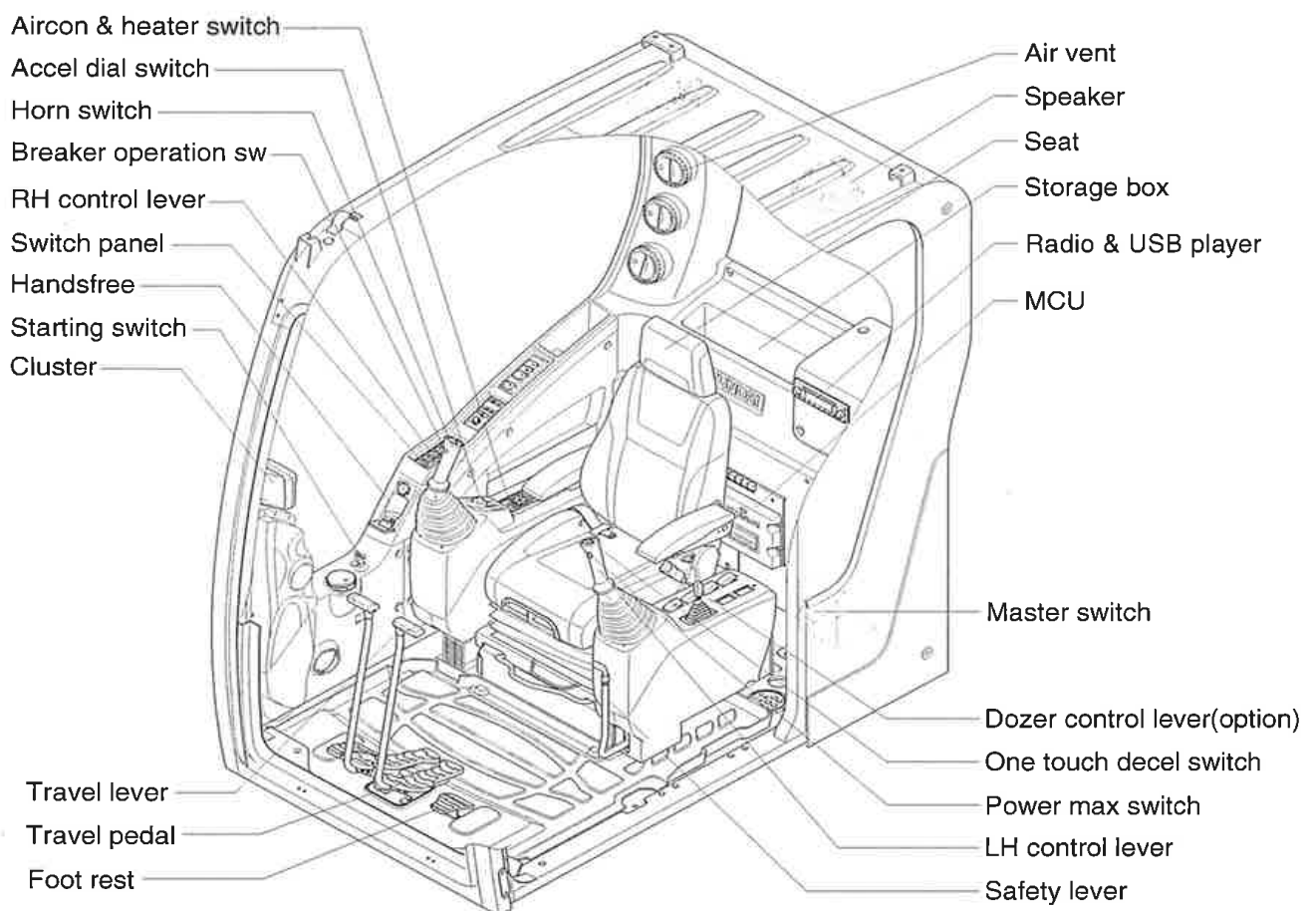

140Z93CD01

2. CLUSTER

1) STRUCTURE

The cluster consists of LCD and switches as shown below. The LCD is to warn the operator in case of abnormal machine operation or conditions for the appropriate operation and inspection. Also, The LCD is to set and display for modes, monitoring and utilities with the switches. The switches are to set the machine operation modes.

- ※ The cluster installed on this machine does not entirely guarantee the condition of the machine. Daily inspection should be performed according to chapter 6, Maintenance.
- ※ When the cluster provides a warning immediately check the problem, and perform the required action.

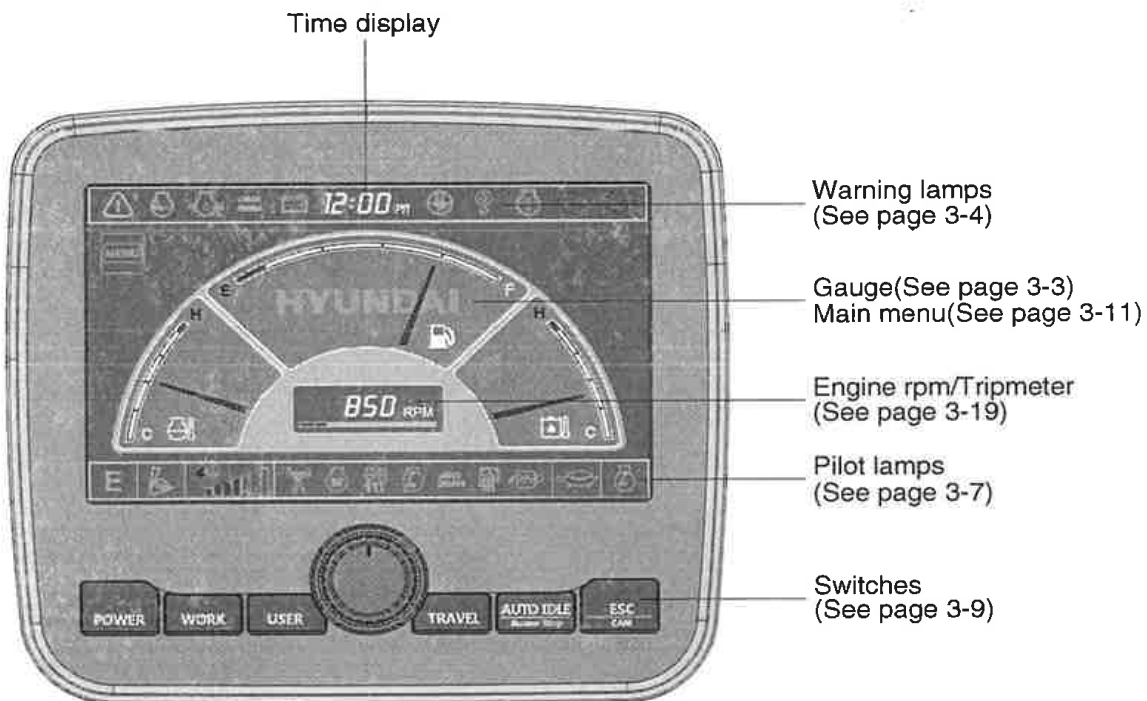

21093CD07

- ※ The warning lamp pops up and/or blinks and the buzzer sounds when the machine has a problem.
The warning lamp blinks until the problem is cleared. Refer to page 3-4 for details.

2) GAUGE



(1) Operation screen



※ Operation screen type can be set by the screen type menu of the display.
Refer to page 3-21 for details.



(2) Engine coolant temperature gauge



- ① This gauge indicates the temperature of coolant.
 - White range : 40-107°C (104-225°F)
 - Red range : Above 107°C (225°F)
 - ② If the indicator is in the red range or  lamp blinks in red, turn OFF the engine and check the engine cooling system.
- ※ If the gauge indicates the red range or  lamp blinks in red even though the machine is on the normal condition, check the electric device as that can be caused by the poor connection of electricity or sensor.



(3) Hydraulic oil temperature gauge



- ① This gauge indicates the temperature of hydraulic oil.
 - White range : 40-105°C (104-221°F)
 - Red range : Above 105°C (221°F)
 - ② If the indicator is in the red range or  lamp blinks is red, reduce the load on the system. If the gauge stays in the red range, stop the machine and check the cause of the problem.
- ※ If the gauge indicates the red range or  lamp blinks in red even though the machine is on the normal condition, check the electric device as that can be caused by the poor connection of electricity or sensor.

(4) Fuel level gauge



- ① This gauge indicates the amount of fuel in the fuel tank.
 - ② Fill the fuel when the red range, or  lamp blinks in red.
- ※ If the gauge indicates the red range or  lamp blinks in red even though the machine is on the normal condition, check the electric device as that can be caused by the poor connection of electricity or sensor.

(5) RPM / Tripmeter display



- ① This displays the engine speed or the tripmeter.
- ※ Refer to page 3-19 for details.



3) WARNING LAMPS



21093CD08D

- ※ Each warning lamp on the top of the LCD pops up on the center of LCD and the buzzer sounds when the each warning is happened. The pop-up warning lamp moves to the original position and blinks when the select switch is pushed. And the buzzer stops. Refer to page 3-10 for the select switch.

(1) Engine coolant temperature



21093CD08A

- ① Engine coolant temperature warning is indicated two steps.
 - 103°C over : The lamp blinks.
 - 107°C over : The lamp pops up on the center of LCD and the buzzer sounds.
- ② The pop-up lamp moves to the original position and blinks when the select switch is pushed. Also, the buzzer stops and lamp keeps blink.
- ③ Check the cooling system when the lamp keeps ON.

(2) Hydraulic oil temperature

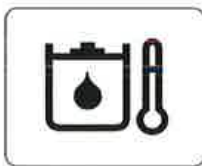

21093CD08C

- ① Hydraulic oil temperature warning is indicated two steps.
 - 100°C over : The lamp blinks and the buzzer sounds.
 - 105°C over : The lamp pops up on the center of LCD and the buzzer sounds.
- ② The pop-up lamp moves to the original position and blinks when the select switch is pushed. Also, the buzzer stops and lamp keeps blink.
- ③ Check the hydraulic oil level and hydraulic oil cooling system.

(3) Fuel level



21093CD08B

- ① This warning lamp blinks and the buzzer sounds when the level of fuel is below 31 l (8.2 U.S. gal).
- ② Fill the fuel immediately when the lamp blinks.

(4) Emergency warning lamp



21093CD30

- ① This lamp pops up and the buzzer sounds when each of the below warnings is happened.
 - Engine coolant overheating (over 107°C)
 - Hydraulic oil overheating (over 105°C)
 - Pump EPPR circuit abnormal or open
 - Attachment flow EPPR circuit abnormal or open
 - MCU input voltage abnormal
 - Accel dial circuit abnormal or open
 - Cluster communication data error
 - Engine ECM communication data error
- ※ The pop-up warning lamp moves to the original position and blinks when the select switch is pushed. Also the buzzer stops. This is same as following warning lamps.
- ② When this warning lamp blinks, machine must be checked and serviced immediately.

(5) Engine oil pressure warning lamp



21093CD32

- ① This lamp blinks when the engine oil pressure is low.
- ② If the lamp blinks, shut OFF the engine immediately. Check oil level.

(6) Check engine warning lamp

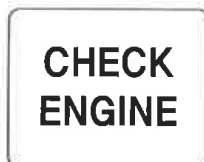

21093CD33



29093CD03

- ① This lamp blinks when the communication between MCU and engine ECM on the engine is abnormal, or if the cluster received any fault code from engine ECM.
- ② Check the communication line between them.
If the communication line is OK, then check the fault codes on the cluster.
- ③ This lamp blinks when "Engine check water in fuel" is displayed in the message box then check water separator.

(7) Battery charging warning lamp

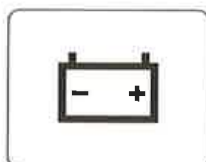

21093CD34

- ① This lamp blinks when the battery charging voltage is low.
- ② Check the battery charging circuit when this lamp blinks.



(8) Air cleaner warning lamp



21093CD35

- ① This lamp blinks when the filter of air cleaner is clogged.
- ② Check the filter and clean or replace it.

(9) Overload warning lamp (opt)



21093CD36

- ① When the machine is overload, the overload warning lamp blinks during the overload switch is ON. (if equipped)
- ② Reduce the machine load.

4) PILOT LAMPS



21093CD09

(1) Mode pilot lamps

No	Mode	Pilot lamp	Selected mode
1	Power mode		Heavy duty power work mode
			Standard power mode
			Economy power mode
2	User mode		User preferable power mode
3	Work mode		General operation mode
			Breaker operation mode
			Crusher operation mode
4	Travel mode		Low speed traveling
			High speed traveling
5	Auto idle mode		Auto idle
6	Work tool mode		Oil flow level of breaker or crusher mode
7	Message display		"Setting is completed" display after selection

(2) Power max pilot lamp



21093CD38

- ① The lamp will be ON when pushing power max switch on the LH RCV lever.
- ② The power max function is operated maximum 8 seconds.
- ※ Refer to the page 3-26 for power max function.

(3) Preheat pilot lamp

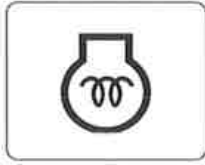

21093CD39

- ① Turning the start key switch ON position starts preheating in cold weather.
- ② Start the engine after this lamp is OFF.

(4) Warming up pilot lamp

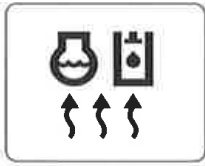

21093CD40

- ① This lamp is turned ON when the coolant temperature is below 30°C (86°F).
- ② The automatic warming up is cancelled when the engine coolant temperature is above 30°C, or when 10 minutes have passed since starting the engine.

(5) Decel pilot lamp



21093CD41

- ① Operating one touch decel switch on the RCV lever makes the lamp ON.
 - ② Also, the lamp will be ON and engine speed will be lowered automatically to save fuel consumption when all levers and pedals are at neutral position, and the auto idle function is selected.
- ※ One touch decel is not available when the auto idle pilot lamp is turned ON.
- ※ Refer to the page 3-26.

(6) Fuel warmer pilot lamp



21093CD43

- ① This lamp is turned ON when the coolant temperature is below 10°C (50°F) or the hydraulic oil temperature 20°C (68°F).
- ② The automatic fuel warming is cancelled when the engine coolant temperature is above 60°C, or the hydraulic oil temperature is above 45°C since the start switch was ON position.

(7) Maintenance pilot lamp

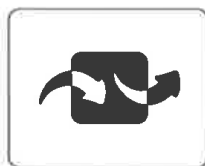

21093CD44

- ① This lamp will be ON when the consuming parts are needed to change or replace. It means that the change or replacement interval of the consuming parts remains below 30 hours.
- ② Check the message in maintenance information of main menu. Also, this lamp lights ON for 3 minutes when the start switch is ON position.

5) SWITCHES

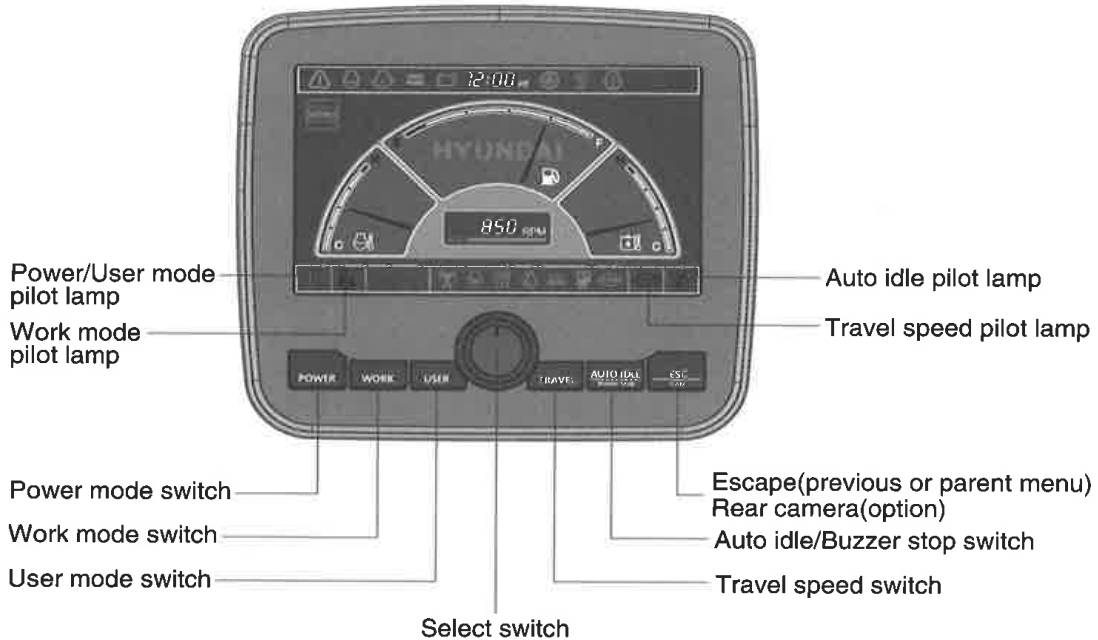

21093CD45

※ When the switches are selected, the pilot lamps are displayed on the LCD. Refer to the page 3-7 for details.

(1) Power mode switch



21093CD45A

① This switch is to select the machine power mode and selected power mode pilot lamp is displayed on the pilot lamp position.

- P : Heavy duty power work.
- S : Standard power work.
- E : Economy power work.



② The pilot lamp changes E → S → P → E in order.

(2) Work mode switch



21093CD45C

① This switch is to select the machine work mode, which shifts from general operation mode to optional attachment operation mode.

-  : General operation mode
-  : Breaker operation mode (if equipped)
-  : Crusher operation mode (if equipped)
- Not installed : Breaker or crusher is not installed.

※ Refer to the page 4-6 for details.

(3) User mode switch



21093CD45D

- ① This switch is used to memorize the current machine operating status in the MCU and activate the memorized user mode.
 - Memory : Push more than 2 seconds.
 - Action : Push within 2 seconds.
 - Cancel : Push this switch once more within 2 seconds.
- ② Refer to the page 3-12 for another set of user mode.

(4) Select switch



21093CD45E

- ① This switch is used to select or change the menu and input value.
- ② Knob push
 - Long (over 2 sec) : Return to the operation screen
 - Medium (0.5~2 sec) : Return to the previous screen
 - Short (below 0.5 sec) : Select menu
- ③ Knob rotation

This knob changes menu and input value.

 - Right turning : Down direction / Increase input value
 - Left turning : Up direction / Decreased input value

(5) Auto idle/ buzzer stop switch





21093CD45F

- ① This switch is used to activate or cancel the auto idle function.
 - Pilot lamp ON : Auto idle function is activated.
 - Pilot lamp OFF : Auto idle function is cancelled.
- ② The buzzer sounds when the machine has a problem. In this case, push this switch and buzzer stops, but the warning lamp blinks until the problem is cleared.

(6) Travel speed control switch



21093CD45G

- ① This switch is used to select the travel speed alternatively.
 -  : High speed
 -  : Low speed

(7) Escape/Camera switch



21093CD45H

- ① This switch is used to return to the previous menu or parent menu.
- ② In the operation screen, pushing this switch will display the view of the camera on the machine (if equipped). Please refer to page 3-22 for the camera.
- ③ If the camera is not installed, this switch is used only ESC function.

6) MAIN MENU



※ Please refer to select switch, page 3-10 for selection and change of menu and input value.

(1) Structure

No	Main menu	Sub menu	Description
1	 Mode 21093CD64D	Work tool U mode power Boom/Arm speed Auto power boost Initial mode Cluster switch (back up)	Breaker, Crusher, Not installed User mode only Boom speed, Arm speed Enable, Disable Default, U mode Switch function
2	 Monitoring 21093CD64E	Active fault Logged fault Delete logged fault Monitoring (analog) Monitoring (digital) Operating hours	MCU, Engine ECM MCU, Engine ECM All logged fault delete, Initialization canceled Machine information Switch status, Output status Operating hours for each mode
3	 Management 21093CD64F	Maintenance information Machine security Machine Information A/S phone number Service menu	Replacement, Change interval oils and filters ESL mode setting, Password change Cluster, MCU, Engine, Machine A/S phone number, A/S phone number change Power shift, Hourmeter, Replacement history, Update
4	 Display 21093CD64G	Display item Clock Brightness Unit Language Screen type	Engine speed, Tripmeter A, Tripmeter B, Tripmeter C Clock Manual, Auto Temperature, Pressure, Flow, Date format Korean, English, Chinese A type, B type
5	 Utilities 21093CD64H	Tripmeter DMB Entertainment Camera setting Message box	3 kinds (A, B, C) DMB select, DAB select, Channel scan, Exit Play MP4, codec. Basic direction, Display switching, Full screen Record for fault, attachment etc.

(2) Mode setup

① Work tool

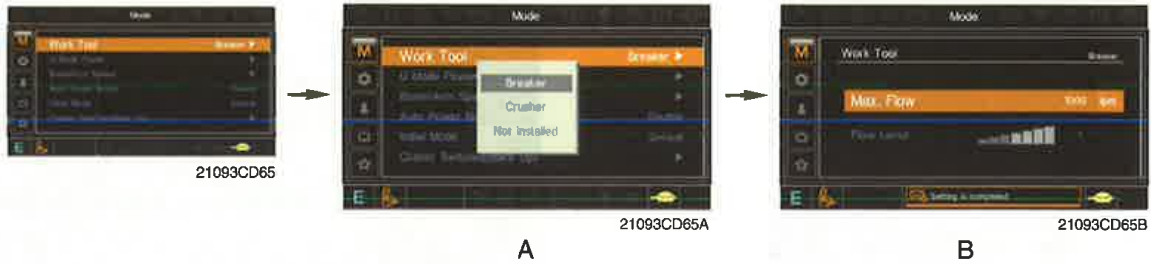

- A : Select one installed optional attachment.
 - B : Max flow - Set the maximum flow for the attachment.
 - Flow level - Reduce the operating flow from maximum flow.
 - Breaker - Max 7 steps, Reduced 10 lpm each step.
 - Crusher - Max 4 steps, Reduced 20 lpm each step.
- ※ The flow level is displayed with the work mode pilot lamp.

② U mode power



- Engine high idle rpm, auto idle rpm and pump torque (power shift) can be modulated and memorized separately in U-mode.
- U-mode can be activated by user mode switch.

Step (■)	Engine speed (rpm)	Idle speed (rpm)	Power shift (bar)
1	1550	800	0
2	1600	850	3
3	1650	900 (low idle)	6
4	1700	950	9
5	1750	1000 (decel rpm)	12
6	1800	1050	16
7	1850	1100	20
8	1900	1150	26
9	1950	1200	32
10	2000	1250	38

③ Boom/Arm speed



- Boom speed
 - Control type
 - Manual - Boom up speed is fixed as set steps.
 - Auto - Boom up speed is automatically adjusted as working conditions by the MCU.
 - Speed setting - Boom up speed is increased as much as activated steps.
- Arm speed
 - Regeneration - Arm regeneration function can be activated or cancelled.
 - Enable - Arm in speed is up.
 - Disable - Fine operation.

④ Auto power boost



- The power boost function can be activated or cancelled.
- Enable - The digging power is automatically increased as working conditions by the MCU. It is operated max 8 seconds.
- Disable - Not operated.

⑤ Initial mode



- Default - The initial power mode is set E mode when the engine is started.
- U mode - The initial power mode is set U mode when the engine is started.

⑥ Cluster switch (back up)



- The cluster switch can be selected and changed by this menu when the switches are abnormal on the cluster.
- In order to exit "Cluster switch" mode, please put the cursor on the ESC/CAM switch by turning the select switch and push the select switch.
- In "Cluster switch", other switches except "Select switch" do not work.

(3) Monitoring

① Active fault



• The active faults of the MCU or engine ECM can be checked by this menu.

② Logged fault



• The logged faults of the MCU or engine ECM can be checked by this menu.

③ Delete logged fault



• The logged faults of the MCU or engine ECM can be deleted by this menu.

④ Monitoring(Analog)



• The machine status such as the engine rpm, oil temperature, voltage and pressure etc. can be checked by this menu.

⑤ Monitoring (digital)



- The switch status or output status can be confirmed by this menu.
- The activated switch or output pilot lamps are light ON.

⑥ Operating hours



- The operating hour of each mode can be confirmed by this menu.

(4) Management

① Maintenance information



- Alarm (⚙️ 🟡 🔴) : Gray ⚙️ - Normal
Yellow 🟡 - First warning
Red 🔴 - Second warning
- Replacement : The elapsed time will be reset to zero (0).
- Change interval : The change or replace interval can be changed in the unit of 50 hours.
- OK : Return to the item list screen.
- Change or replace interval

No	Item	Interval
1	Engine oil	500
2	Final gear oil	1000
3	Swing gear oil	1000
4	*Hydraulic oil	5000
5	Pilot line filter	1000
6	Drain filter	1000
7	Hydraulic oil return filter	1000
8	Engine oil filter	500
9	Fuel filter	500
10	Pre-filter	500
11	Hydraulic tank breather	250
12	Air cleaner (inner)	500
13	Radiator coolant	2000
14	Swing gear pinion grease	1000

* : Hyundai genuine long life hydraulic oil

② Machine security



• ESL mode

- ESL : Engine Starting Limit
- ESL mode is designed to be a theft deterrent or will prevent the unauthorized operation of the machine.
- If the ESL mode was selected Enable, the password will be required when the start switch is turned ON.
- Disable : Not used ESL function
- Enable (always) : The password is required whenever the operator start engine.
- Enable (interval) : The password is required when the operator start engine first. But the operator can restart the engine within the interval time without inputting the password. The interval time can be set maximum 4 hours.



• Password change

- The password is 5~10 digits.

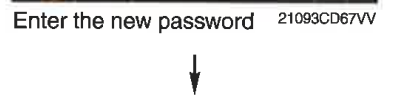

The new password is stored in the MCU.

Enter the new password again

③ Machine Information



• This can confirm the identification of the cluster, MCU, engine and machine.

④ A/S phone number



⑤ Service menu



- Power shift (standard/option) : Power shift pressure can be set by option menu.
- Hourmeter : Operating hours since the machine line out can be checked by this menu.
- Replacement history : Replacement history of the MCU and cluster can be checked by this menu.
- Update : Firm ware can be upgraded by this menu. (the USB port is located under the cluster)

(5) Display

① Display item



- The center display type of the LCD can be selected by this menu.
- The engine speed or each of the tripmeter (A,B,C) is displayed on the center display.

② Clock



- The first line's three spots "**/**/****" represent Month/Day/Year each.
- The second line shows the current time. (0:00~23:59)

③ Brightness

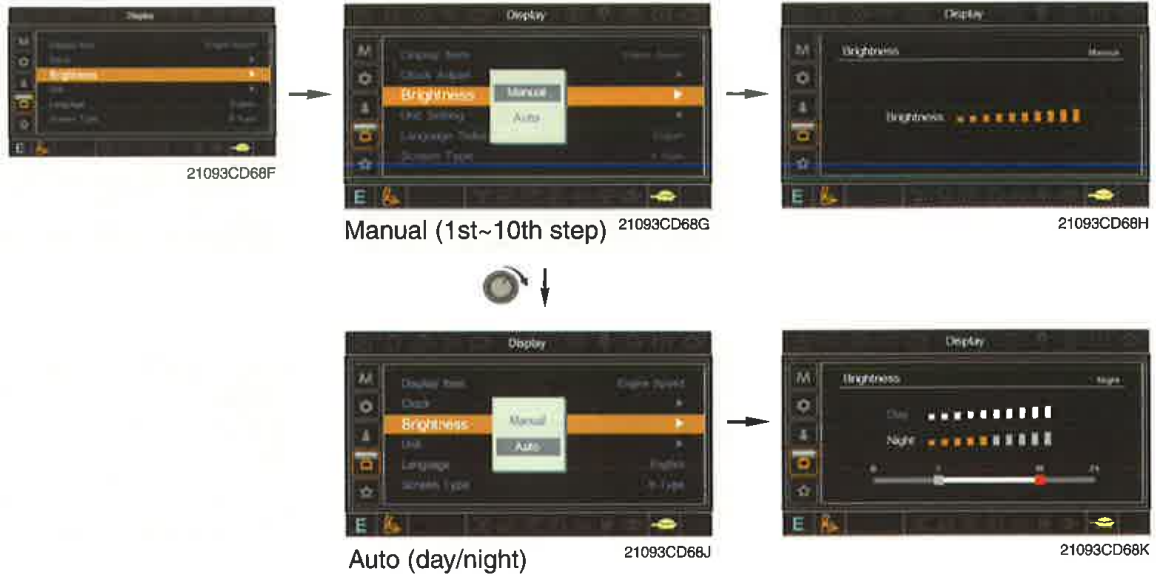

※ If "Auto" is chosen, brightness for day and night can be differently set up. Also by using the bar in lower side, users can define which time interval belongs to day and night. (in bar figure, gray area represents night time while white shows day time)

④ Unit



- Temperature : °C ↔ °F
- Pressure : bar ↔ MPa ↔ kgf/cm²
- Flow : lpm ↔ gpm
- Date format : yy/mm/dd ↔ mm/dd/yy ↔ dd-Mar-yy

⑤ Language



- User can select preferable language and all displays are changed the selected language.

⑥ Screen type

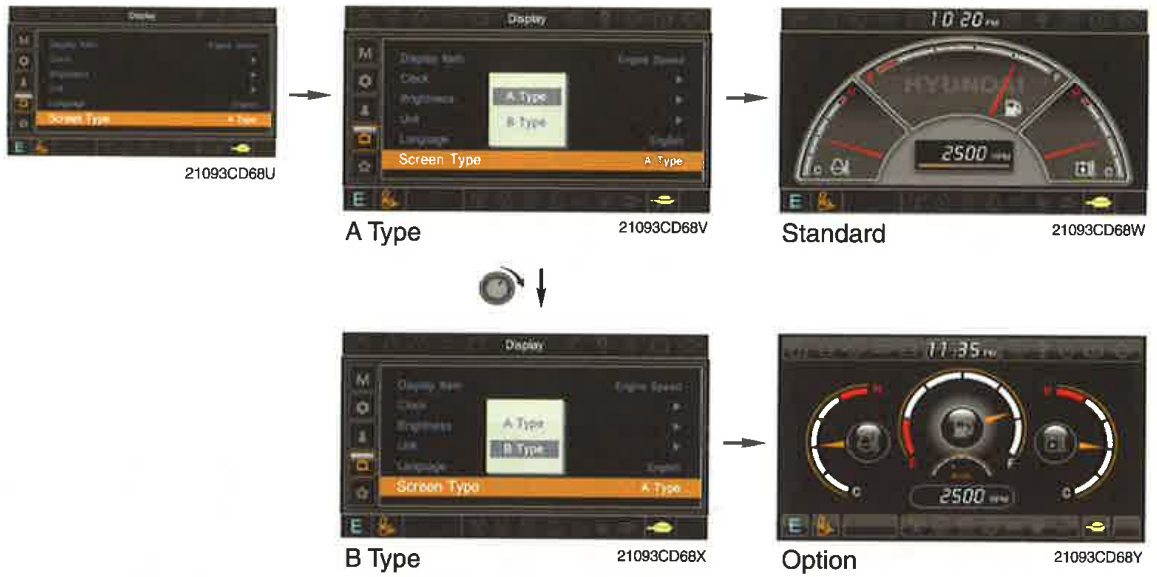

(6) Utilities

① Tripmeter



- Maximum 3 kinds of tripmeters can be used at the same time.
- Each tripmeter can be turned on by choosing "Start" while it also can be turned off by choosing "Stop".
- If the tripmeter icon is activated in the operation screen, it can be controlled directly there.

② DMB



- DMB select : TV channel can be selected by this menu.
- DAB select : Audio channel can be selected by this menu.
- Channel scan : This menu can be used other region for TV/Audio.
- Exit : Exit DMB menu

③ Entertainment

- Play MP4 or codec file of external hard disk through USB port.
- The USB port is located under the cluster.

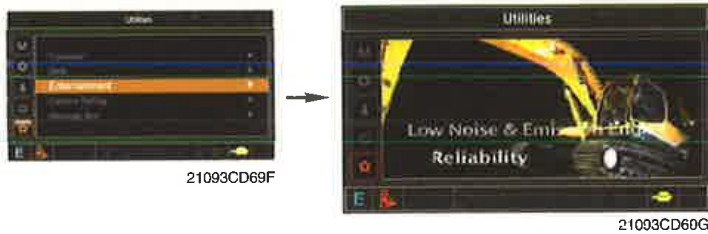

④ Camera setting



- Three cameras can be installed on the machine.
- The display order can be set by this menu.



- If the camera was not equipped, this menu is not useful.
- In the operation screen, if the ESC/CAM switch is pushed, the first ordered display camera will be viewed.
- Turning the select switch in clockwise direction, the next ordered will be shown and in counter-clockwise direction, the previously ordered will be shown.
- Push the select switch, the displayed screen will be enlargement.

⑤ Message box

- The history of the machine operating status can be checked by this menu.



3. SWITCHES

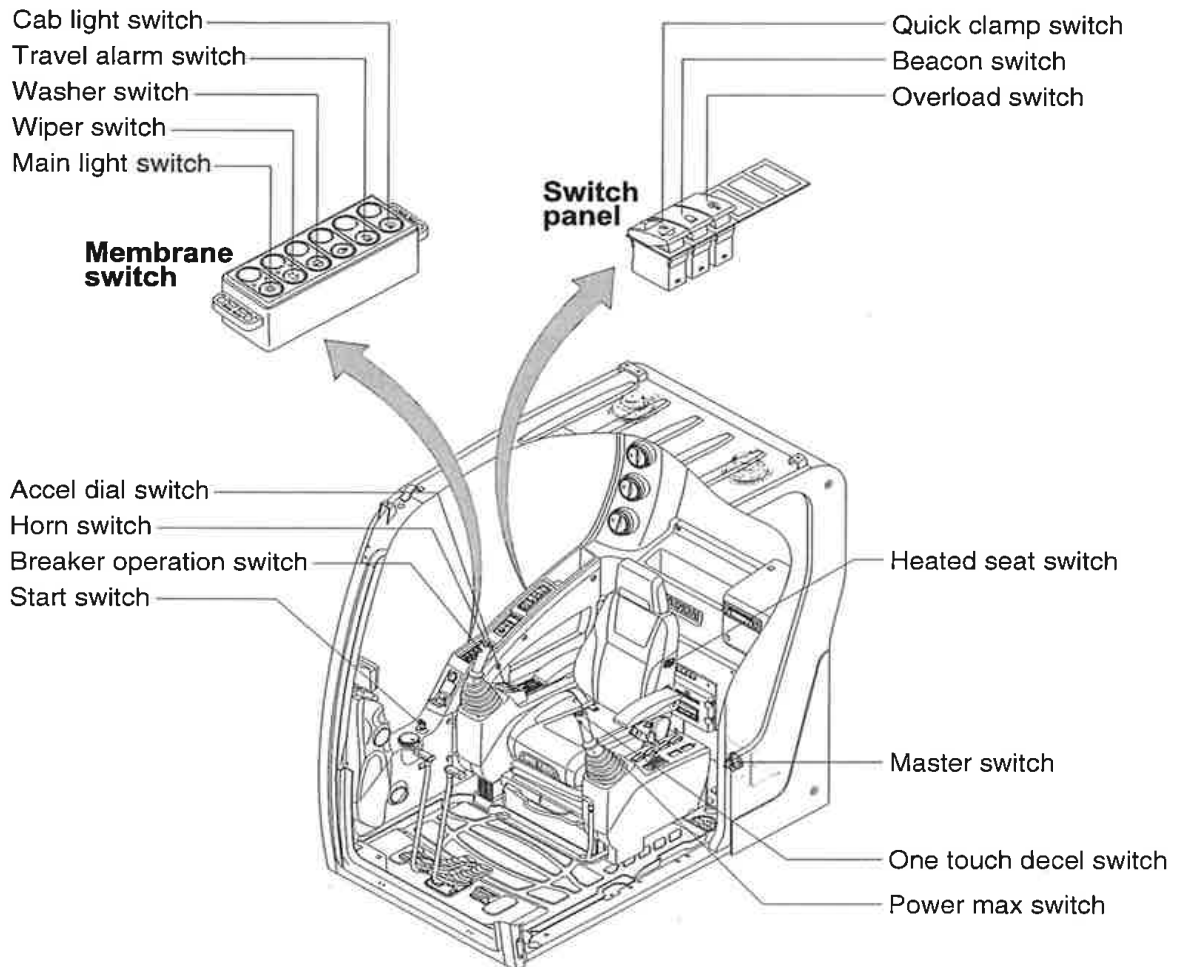

140Z93CD47

1) STARTING SWITCH

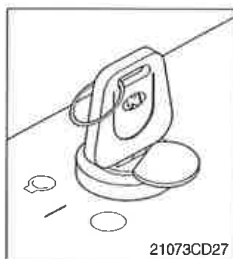

(1) There are three positions, OFF, ON and START.

- ○ (OFF) : None of electrical circuits activate.
- | (ON) : All the systems of machine operate.
- ◯ (START) : Use when starting the engine.

Release key immediately after starting.

- ※ If you turn ON the starting switch in cold weather, the fuel warmer is automatically operated to heat the fuel by sensing the coolant temperature. Start the engine in 1~2 minutes after turning ON the starting switch. More time may take according to ambient temperature.
- ※ Key must be in the ON position with engine running to maintain electrical and hydraulic function and prevent serious machine damage.

2) MASTER SWITCH

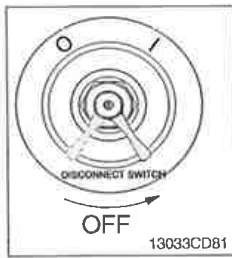

- (1) This switch is used to shut off the entire electrical system.
 - (2) I : The battery remains connected to the electrical system.
O : The battery is disconnected to the electrical system.
- ※ **Never turn the master switch to O (OFF) with the engine running. Engine and electrical system damage could result.**

3) ACCEL DIAL SWITCH



- (1) There are 10 dial setting.
- (2) Setting 1 is low idle and setting 10 is high idle.
 - By rotating the accel dial to right : Engine speed increases
 - By rotating the accel dial to left : Engine speed decreases

4) MAIN LIGHT SWITCH

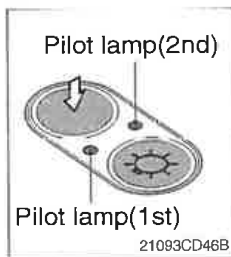

- (1) This switch used to operate the head light and work light.
 - Press the switch once, the head light comes ON and the 1st pilot lamp ON.
 - Press the switch once more, the work light comes ON and the 2nd pilot lamp ON.
 - Press the switch again, return to a first step position.
 - Press the switch more than one second to turn off lights.

5) WIPER SWITCH

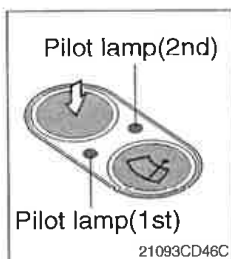

- (1) This switch used to operate wiper.
 - Press the switch once the wiper operates intermittently and the 1st pilot lamp comes ON.
 - Press the switch once more, the wiper operates low speed and the 2nd pilot lamp comes ON.
 - Press the switch again return to a first step position.
 - Press the switch more than one second to turn off wiper.

6) WASHER SWITCH

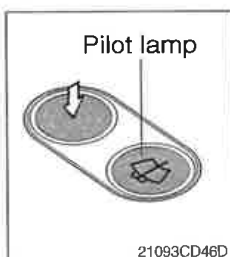

- (1) The washer liquid is sprayed and the wiper is operated only while pressing this switch.
- (2) The pilot lamp is turned ON when operating this switch.

7) TRAVEL ALARM SWITCH

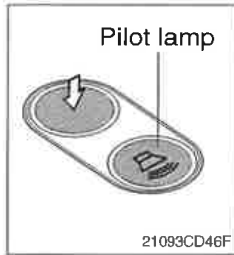

- (1) This switch is to activate travel alarm function surrounding when the machine travels to forward and backward.
- (2) On pressing this switch, the alarm operates only when the machine is traveling.

8) CAB LIGHT SWITCH (option)

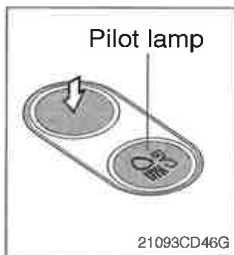

- (1) This switch turns ON the cab light on the cab.

9) OVERLOAD SWITCH (option)



- (1) When this switch turned ON, buzzer makes sound and overload warning lamp comes ON in case that the machine is overload.
- (2) When it turned OFF, buzzer stops and warning lamp goes out.

10) QUICK CLAMP SWITCH (option)



- (1) This switch is used to engage or disengage the moving hook on quick clamp.
- ※ Refer to the page 8-6 for details.

11) BEACON SWITCH (option)



- (1) This switch turns ON the rotary light on the cab.
- (2) The indicator lamp is turned ON when operating this switch.

12) HEATED SEAT SWITCH (option)



- (1) This switch is used to heat the seat.
 - Heater ON : $10 \pm 3.5^{\circ}\text{C}$
 - Heater OFF : $20 \pm 3^{\circ}\text{C}$
- (2) On pressing the switch, the indicator lamp is turned ON.

13) HORN SWITCH

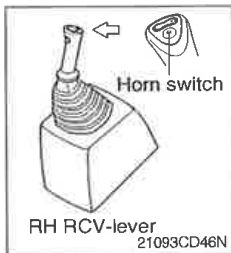

- (1) This switch is at the top of right side control lever. On pressing, the horn sounds.

14) BREAKER OPERATION SWITCH

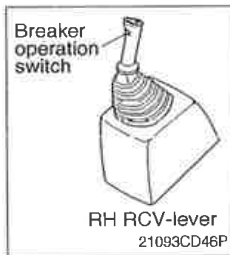

- (1) On pressing this switch, the breaker operates only when the breaker operation mode is selected.

15) ONE TOUCH DECEL SWITCH

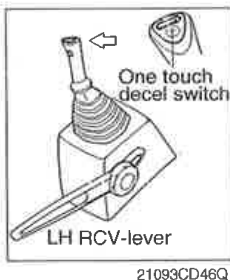

- (1) This switch is used to actuate the deceleration function quickly.
- (2) The engine speed is increased to previous setting value by pressing the switch again.
- (3) One touch decel function is available only when the auto idle pilot lamp is turned OFF.

16) POWER MAX SWITCH

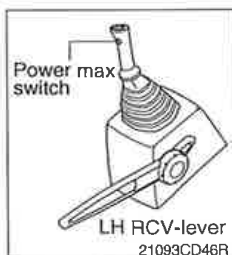

- (1) This switch activate power max function. When this switch is kept pressed, hydraulic power of work equipment will be increased to approx 110 percent during 8 seconds.
 - (2) After 8 seconds, function is cancelled automatically even the switch keeps pressed.
- ※ Do not use for craning purposes.

4. LEVERS AND PEDALS

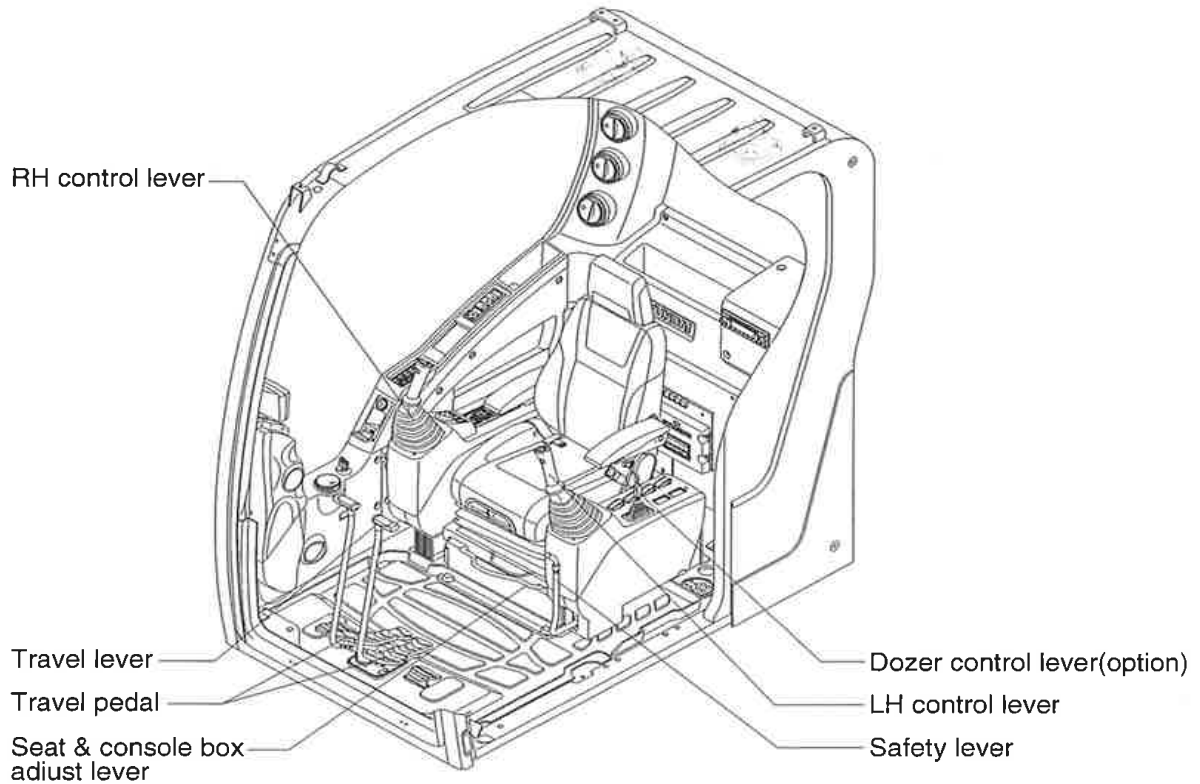

140Z93CD48

1) LH CONTROL LEVER



- (1) This joystick is used to control the swing and the arm.
- (2) Refer to operation of working device in chapter 4 for details.

2) RH CONTROL LEVER

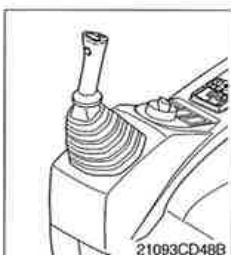

- (1) This joystick is used to control the boom and the bucket.
- (2) Refer to operation of working device in chapter 4 for details.

3) SAFETY LEVER

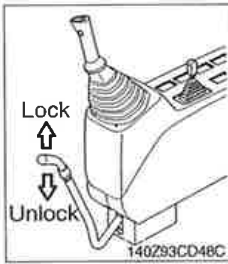

- (1) All control levers and pedals are disabled from operation by locating the lever to lock position as shown.
 - ※ Be sure to raise the lever to LOCK position when leaving from operator's seat.
- (2) By push lever to UNLOCK position, the machine is operational.
 - ※ Do not use the safety lever for handle when getting on or off the machine.

4) TRAVEL LEVER



- (1) This lever is mounted on travel pedal and used for traveling by hand. The operation principle is same as the travel pedal.
- (2) Refer to traveling of the machine in chapter 4 for details.

5) TRAVEL PEDAL



- (1) This pedal is used to move the machine forward or backward.
- (2) If left side pedal is pressed, left track will move.
If right side pedal is pressed, right track will move.
- (3) Refer to traveling of machine in chapter 4 for details.

6) SEAT AND CONSOLE BOX ADJUST LEVER

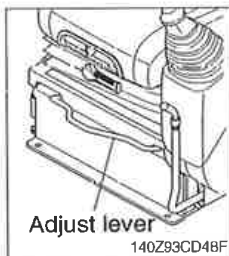

- (1) This lever is used to move the seat and console box to fit the contours of the operator's body.
- (2) Pull the lever to adjust forward or backward over 170 mm (6.7").

7) DOZER CONTROL LEVER (option)

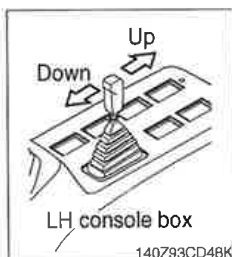

- (1) This lever is used to operate the dozer blade.
- (2) If the lever is pushed forward, the dozer blade will be going down.
And the lever is pulled back, the dozer blade will be going up.

5. AIR CONDITIONER AND HEATER

■ FULL AUTO AIR CONDITIONER AND HEATER (standard)

Full auto air conditioner and heater system automatically keeps the optimum condition in accordance with operator's temperature configuration sensing ambient and cabin inside temperature.

※ Refer to the page 3-33 for semi auto air conditioner and heater.

- Location of air flow ducts

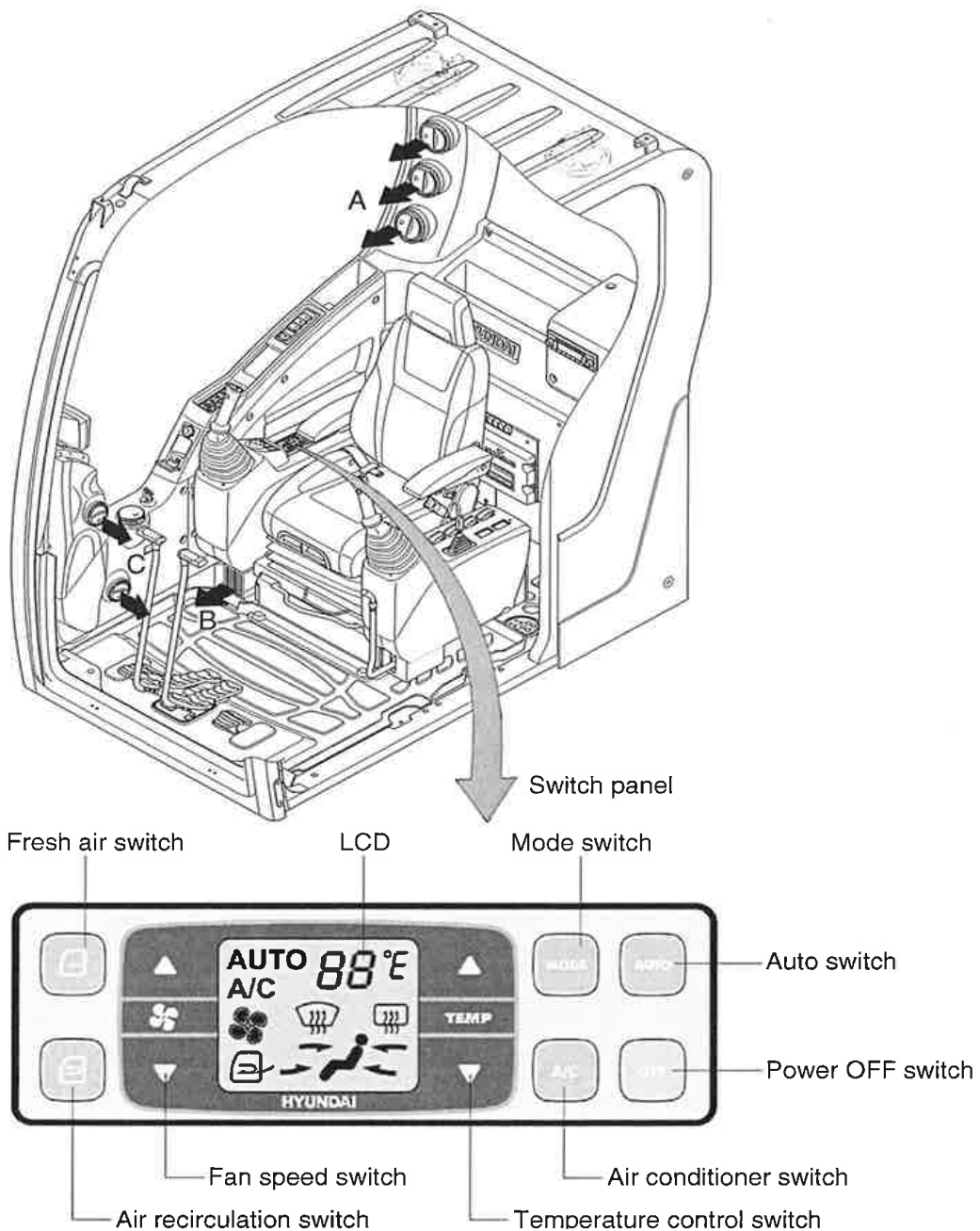

140Z93CD49

1) POWER OFF SWITCH



- (1) This switch makes the system and the LED OFF.
Just before the power OFF, set values are stored.

(2) Default setting values

Function	Air conditioner	In/outlet	LCD	Temperature	Mode
Value	OFF	Inlet	OFF	Previous sw OFF	Previous sw OFF

2) AUTO SWITCH



- (1) Turn the starting switch to ON position, LCD lights ON.
Auto air conditioner and heater system automatically keeps the optimum condition in accordance with operator's temperature configuration sensing ambient and cabin inside temperature.

- (2) This switch can restart system after system OFF.

3) AIR CONDITIONER SWITCH (compressor switch)



- (1) This switch turns the compressor and the LCD ON.
- (2) In accordance with the temperature sensed by duct (evaporator) sensor, compressor turns ON or OFF automatically.
- ※ Air conditioner operates to remove vapor and drains water through a drain hose. Water can be sprayed into the cab in case that the drain cock at the ending point of drain hose has a problem.

In this case, exchange the drain cock.

4) FAN SPEED SWITCH

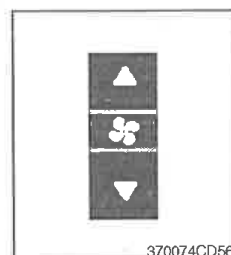

- (1) Fan speed is controlled automatically by setted temperature.
- (2) This switch controls fan speed manually.
- There are 8 up/down steps to control fan speed.
 - The maximum step or the minimum step beeps 5 times.
- (3) This switch makes the system ON.

5) TEMPERATURE CONTROL SWITCH



- (1) Setting temperature indication
 - ① Type A : 17~32°C, scale : 1°C
 - ② Type B : Lo, 18~31°C, Hi, scale : 1°C
- (2) Max cool and max warm beeps 5 times.
- (3) The max cool or the max warm position operates as following table.

Temperature	Compressor	Fan speed	In/Outlet	Mode
Max cool	ON	Max (Hi)	Recirculation	Vent
Max warm	OFF	Max (Hi)	Fresh	Foot

- (4) Temperature unit can be changed between celsius (°C) and fahrenheit (°F)
 - ① Default status (°C)
 - ② Push Up/Down temperature control switch simultaneously more than 5 second displayed temperature unit change (°C → °F)

6) MODE SWITCH

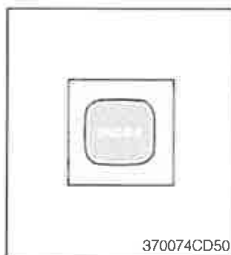

- (1) Operating this switch, it beeps and displays symbol of each mode in order. (Vent → Vent/Foot → Foot → Foot/Def → Vent)

Mode switch		Vent	Vent/Foot	Foot	Foot/Def
Outlet	A	●	●		
	B		●	●	●
	C				●

- (2) When defroster switch operating, FRESH AIR/AIR RECIRCULATION switch turns to FRESH AIR mode and air conditioner switch turns ON.
- (3) When this switch ON, the system operates with previous configuration.

7) FRESH AIR/AIR RECIRCULATION SWITCH



- (1) It is possible to change the air-inlet method.
 - ① Fresh air ()
Inhaling air from the outside.
* Check out the fresh air filter periodically to keep a good efficiency.
 - ② Air recirculation ()
It recycles the heated or cooled air to increase the energy efficiency.
* Change air occasionally when using recirculation for a long time.
* Check out the recirculation filter periodically to keep a good efficiency.



8) SELF DIAGNOSIS FUNCTION

(1) Procedure

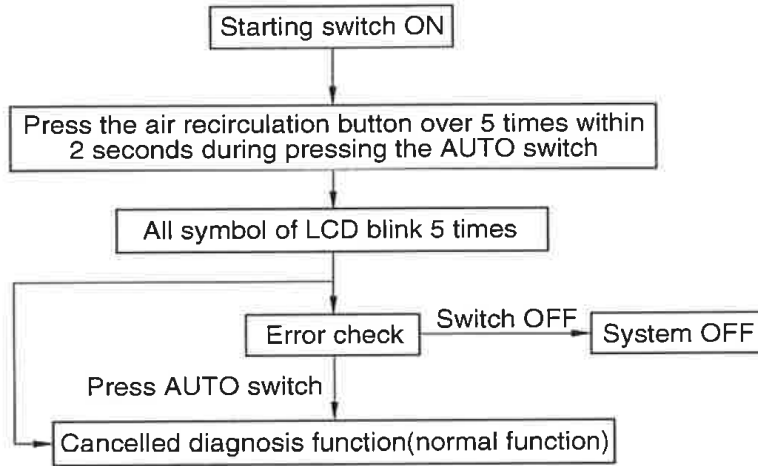

3607A3CD69

(2) Error check

- The corresponding error code flickers on the setup temperature display panel, the other symbol bol will turn OFF.
- Error code flickers every 0.5 second.
- If error code is more than two, each code flickers 2 times in sequence.
- Error code

Error code	Description	Error code	Description
11	Cabin inside sensor	15	Temp actuator
12	Ambient sensor	16	Mode actuator 1
13	Coolant temp sensor	17	Mode actuator 2
14	Duct (evaporator) sensor	18	Intake actuator

(3) Fail safe function

Error description	Fail safe function
Cabin inside sensor (11)	25°C alternate value control
Ambient sensor (12)	20°C alternate value control
Coolant temp sensor (13)	More than 10 minutes after engine start up, the alternate value is ON
Duct (evaporator) sensor (14)	1°C alternate value control
Temp actuator (15)	If opening amount is 0 %, the alternate value is 0 %
	If not, the alternate value is 100 %
Mode actuator 1, 2 (16, 17)	The alternate value is Vent



■ SEMI AUTO AIR CONDITIONER AND HEATER (option)

Semi auto air conditioner and heater are equipped for pleasant operation against outside temperature and defrost on window glass.

※ Refer to the page 3-29 for full auto air conditioner and heater.

· Location of air flow ducts

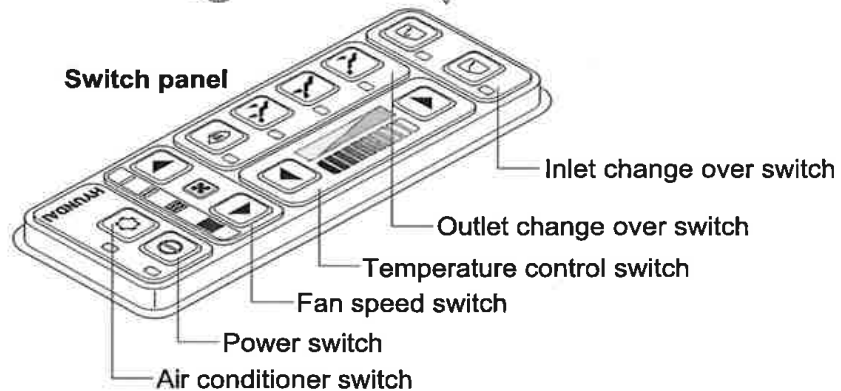
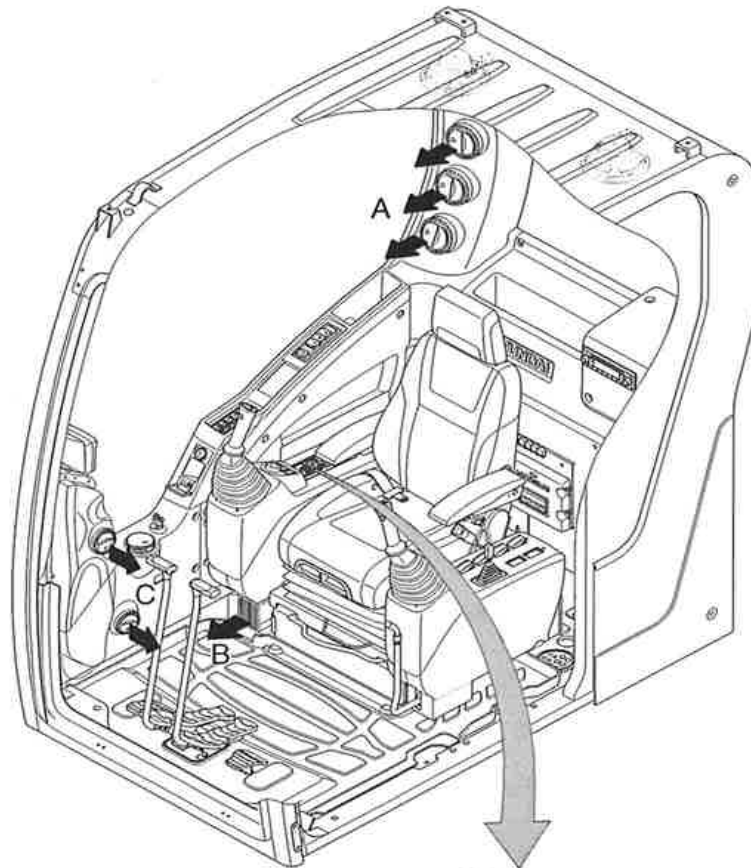

140Z93CD53

1) POWER SWITCH

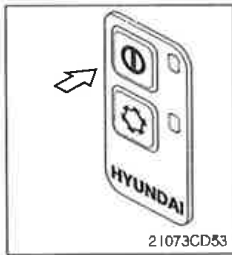

(1) This switch makes the system and the LED simultaneously ON or OFF.

(2) Default setting values

Function	Air conditioner	Fan speed	Temperature	Outlet	Inlet
Value	OFF	1	Max cool	Face	Recirculation

2) AIR CONDITIONER SWITCH (compressor switch)

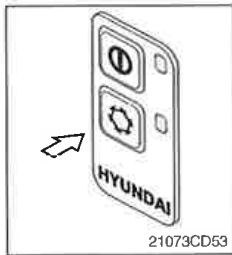

(1) Operating this switch turns the compressor and the LED simultaneously ON or OFF.

(2) In accordance with the evaporator temperature, compressor turns on or off automatically without changing LED state.

※ **Air conditioner operates to remove vapor and drains water through a drain hose. Water can be sprayed into the cab in case that the vacuum valve of drain hose has a problem. In this case, exchange the vacuum valve.**

3) FAN SPEED SWITCH

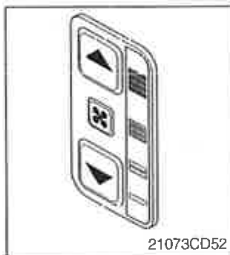

(1) It is possible to control the fan to four steps.

(2) The first step or the fourth step gives 5 times beeps.

4) TEMPERATURE CONTROL SWITCH

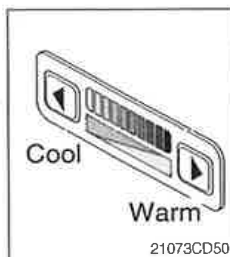

(1) There are 9 steps to control temperature from max cool to max warm controlled up and down by 1 step.

(2) Max cool and max warm arouse 5 times beeps.

(3) For the max warm or the max cool it's better to be configured as following table.

Temperature	Air conditioner	Fan speed	Outlet	Inlet
Max cool	ON	4	Face	Recirculation
Max warm	OFF	3	Foot	Fresh

5) OUTLET CHANGE OVER SWITCH

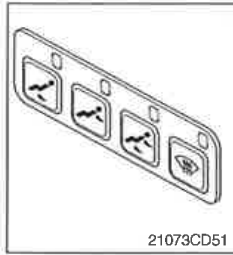

(1) There are four steps of air flow.

Switch position		Mode			
Outlet	A		●	●	
	B	●		●	●
	C				●

(2) When defroster switch operating, INLET switch turns to FRESH mode and air conditioner switch turns ON.

(3) In case of heating range (5~Max warm), air conditioner won't turn ON.

6) INLET CHANGE OVER SWITCH

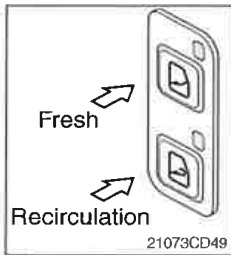

(1) It is possible to change the air-inlet method.

① Fresh

Inhaling air from the outside to pressurize cab inside.

※ Check out the fresh air filter periodically to keep a good efficiency.

② Recirculation

It recycles the heated or cooled air to increase the energy efficiency.

※ Change air occasionally when using recirculation for a long time.

※ Check out the recirculation filter periodically to keep a good efficiency.

(2) Recirculation function operates when the system is OFF but it can be changed whenever needed.

6. OTHERS

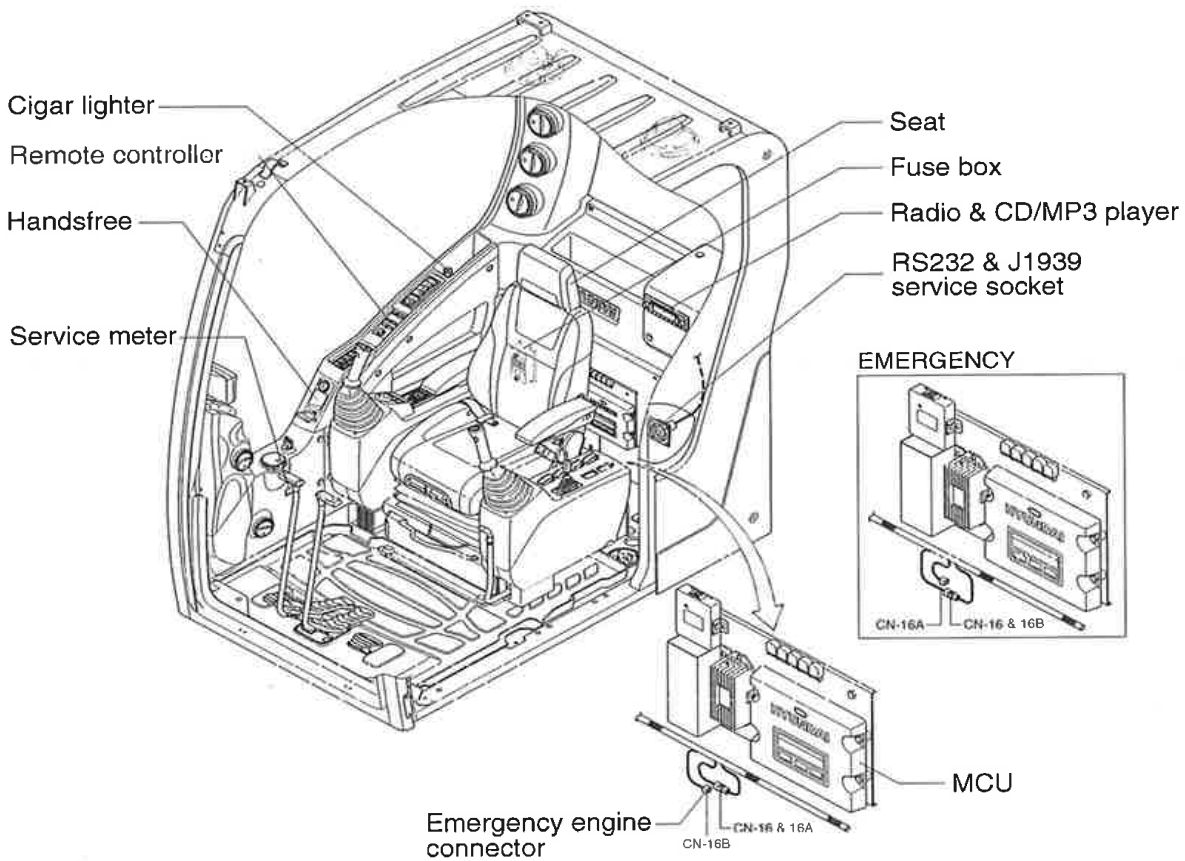

140Z93CD50

1) CIGAR LIGHTER



- (1) This can be used when the engine starting switch is ON.
- (2) The lighter can be used when it springs out in a short while after being pressed down.

※ Service socket

Use cigar lighter socket when you need emergency power.
Do not use the lighter exceeding 24V, 100W.

2) HANDSFREE

Allow you to dial a call or to have a conversation without holding your handset. Use the remote controller when making and answering a calls or ring off.

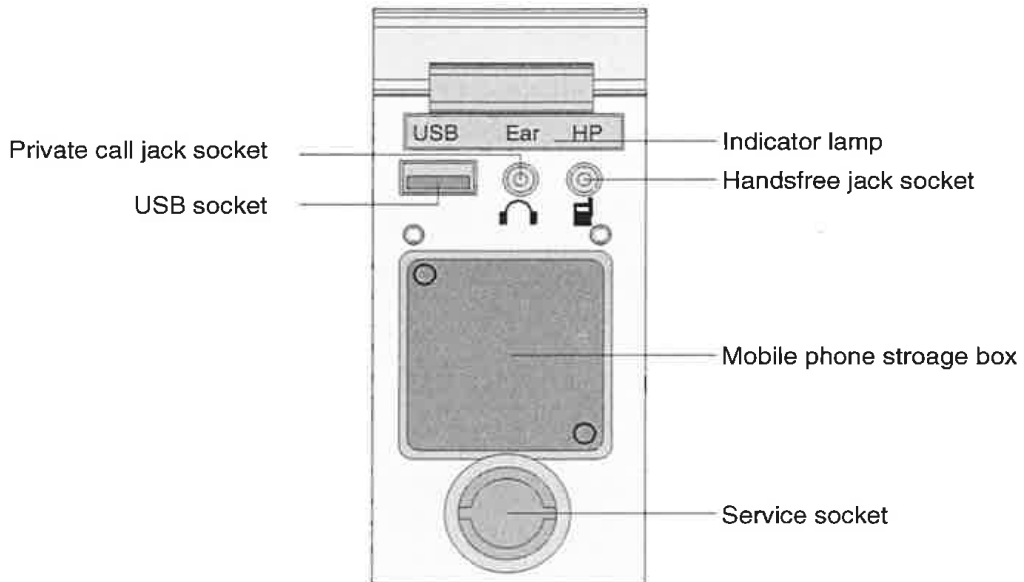

21093CD51

(1) Mobile phone storage box

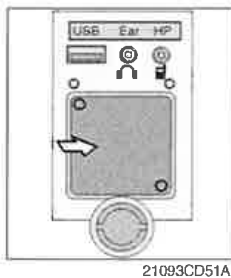

21093CD51A

- ① Mobile phone can be stored when call by handsfree.

(2) USB socket



21093CD51B

- ① This socket is used to charging the mobile phone.

(3) Private call jack socket

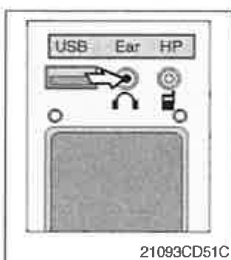

21093CD51C

- ① This can be used protect you privacy calling by using ear phone.
- ② The mobile phone must be connected handsfree jack socket.



(4) Handsfree jack socket



- ① Connect the jack cable when call by handsfree.
- ② Use the special adapter when jack cable is not interchangeable.
- ③ Check the jack type of mobile phone before use.

(5) Indicator lamp



- ① This lamp is turned ON when the handsfree mode selected.

(6) Service socket

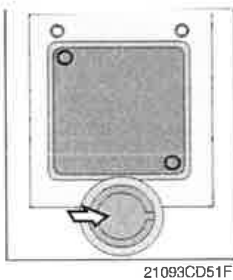

- ① Utilize the power of 12 V as your need and do not exceed power of 12 V, 30 W.

3) REMOTE CONTROLLER

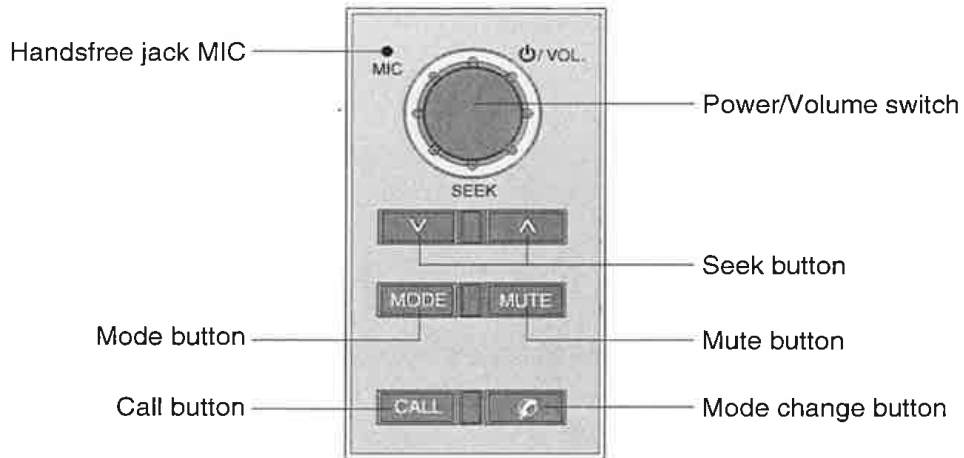

21093CD52

(1) Power and volume switch



21093CD52A

- ① This switch is used to turn the audio or handsfree ON or OFF.
 - ② This switch is turned to right, the handsfree volume is increased over 7 steps.
 - ③ If it is turned to left, volume will be decreased.
- ※ This switch adjust the audio volume when selected audio mode.

(2) Mode change button



21093CD52B

- ① This button is to select the handsfree mode or audio mode.
 - Lamp ON : Handsfree mode ("TEL MUTE" displayed ON audio LCD)
 - Lamp OFF : Audio mode

(3) Call button

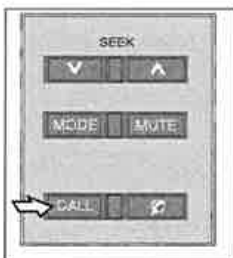

21093CD52C

- ① This button is used answer a call, last number redial, ring off.
 - ② For calling, press the button over 0.5sec within 3 seconds until the beep sounds.
- ※ This can be used when the starting switch is ON.

(4) Handsfree jack MIC



21093CD52D

- ① This MIC transfers user voice to receiver of the call when making a call by handsfree.

(5) Seek button

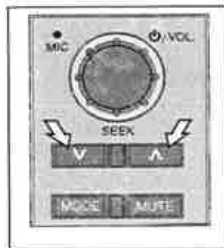

21093CD52E

- ① If this button pressed, the radio automatically stops at the next frequency of broadcasting for your listening.
- ② Press to turn a station of a higher frequency or to a lower frequency.

(6) Mute button

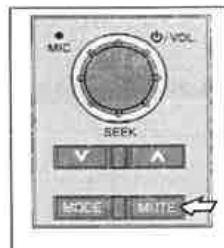

21093CD52G

- ① Short press this button to mute or cancel the mute (silence) while broadcasting.

(7) Mode button

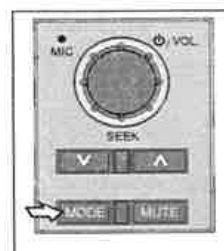

21093CD52F





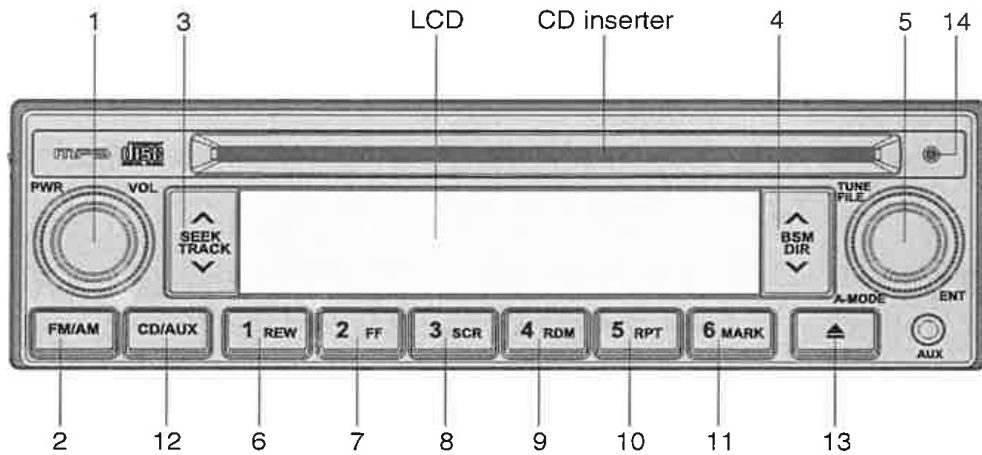







- ① Press the mode button to select the desired mode.
- ② FM1 → FM2 → AM → CD → MP3 → FM1
- * The LCD displayed each mode.

4) RADIO AND CD/MP3 PLAYER



21093CD70

■ FRONT PANEL PRESENTATION

- | | |
|---|--|
| <p>1  Power and volume switch
PWR Press to power on/off
VOL Turn right/left to adjust the volume</p> <p>2  AM/FM button (radio)</p> <p>3  Seek mode (radio)
Auto search up/down
Track mode(CD)
Short press : Next/previous track
Long press : Fast forward or rewind
Memory file search up/down (MP3)</p> <p>4  BSM mode (radio)
6 best station automatic memory
DIR mode (MP3)
Select the desired folder (MP3)
Long press : Fast forward or rewind</p> <p>5  Manual frequency search (radio)
Turn right/left to adjust the frequency
FILE Search for desired file (CD/MP3)
Turn right/left to adjust the track no
A · MODE ... Select bass/middle/treble (radio)
ENT Select the desired track (CD/MP3)</p> | <p>6  Preset memory button 1
REW Fast rewind (CD)</p> <p>7  Preset memory button 2
FF Fast forward (CD)</p> <p>8  Preset memory button 3
SCR Scroll button (CD-MP3)</p> <p>9  Preset memory button 4
RDM CD random playback on/off</p> <p>10  Preset memory button 5
RPT CD repeat track on/off</p> <p>11  Preset memory button 6
MARK Long press : MP3 file memory/deletion
Short press : Memory file playback</p> <p>12  CD playback button
Press to CD insert</p> <p>13  Disc eject (CD)</p> <p>14 CD indicator lamp</p> |
|---|--|

■ RADIO

(1) Power and volume switch

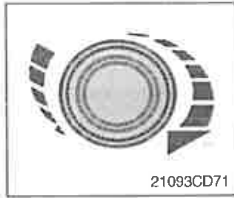

① **Power ON/OFF**

This switch is used to turn the audio ON or OFF.

② **Volume**

This switch turned to right or left, the sound is increased or decreased.

(2) FM/AM button



① You can broadcasting on AM or FM band by pressing this band selection button.



② The bands are changed in the following order.

FM1 → FM2 → AM → FM1

(3) Seek button



① If this button pressed, the radio automatically stops at the next frequency of broadcasting for your listening.

② Press  to turn a station of a higher frequency or  to a lower frequency.

(4) BSM (best station memory) button



① You can automatically memory 6 strongest FM stations on the FM BSM band or 6 strongest AM stations on the AM BSM band.

- Press BSM to active best station memory.
- The set gives a beep and then mutes.
- When it has finished, you heard a beep followed by the station memoried on preset 1.
- Sometimes it may not be possible to find 6 stations.

(5) Manual tuning/audio mode button

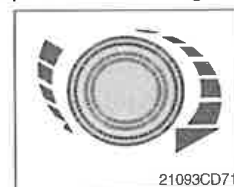

① It is possible to change manual tuning while broadcasting.

- Turned to right or left, the frequency is increased or decreased.

② **Audio mode (Bass/Middle/Treble)**

- Press this button to select desired audio mode.
- Adjust the settings with the volume button right/left.
 - BASS : Press the button once
 - MIDDLE : Press the button twice
 - TREBLE : Press the button three times

③ If it is pressed four times, BALANCE will be selected.

- Turned to clockwise, the LH speaker volume is decreased and counterclockwise, the RH speaker volume is decreased.

(6) Preset memory button

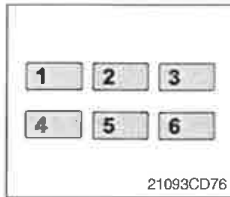

① Manually storing stations in a preset

Six stations per band can be stored and recalled using the preset keys (1 to 6).

- Tune in to the desired station.
- Press the desired preset key (1 to 6) for more than 0.8 seconds to store the current tuned station.

② Recalling a preset

Press the desired preset key (1 to 6) to recall the stored station.

(7) Frequency band setting

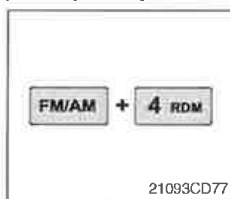

① America : Press **FM/AM** and **4 RDM** button at the same time. "nA" will be displayed on the LCD for one second.

AM : Frequency changes in 10kHz between 530 to 1710kHz.

FM : Frequency changes in 0.2MHz between 87.7 to 107.9MHz.

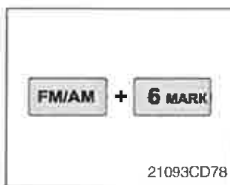

① EUROPE : Press **FM/AM** and **6 MARK** button at the same time. "Eu" will be displayed on the LCD for one second.

LW : Frequency changes in 9kHz between 153 to 279kHz.

MW : Frequency changes in 9kHz between 531 to 1620kHz.

FM : Frequency changes in 0.05MHz between 87.5 to 108.0MHz.

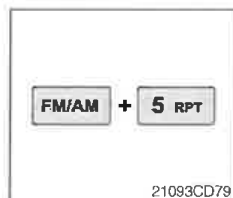

① General : Press **FM/AM** and **5 RPT** button at the same time. "inT" will be displayed on the LCD for one second.

AM : Frequency changes in 9kHz between 531 to 1602kHz.

FM : Frequency changes in 0.1MHz between 87.5 to 108.0MHz.

■ CD/MP3 PLAYER

(1) CD playback button



- ① It is possible to change CD playback during broadcasting.
- ② If there was no CD on audio, "NO DISC" displays on LCD during 5 seconds.

(2) Track button



- ① CD player
 - Short press : Select the next/previous track
 - Long press : Select the fast forward or rewind
- ② MP3 player
 - Memory file search up/down

(3) DIR mode button (MP3)



- ① You can find the desired mp3 folder up/down.
- ② If you find desired folder, press the file search button to playback the first file in the folder.
- ※ If a file is not selected until 5 seconds after search folder, the function will be terminated.

(4) File search button

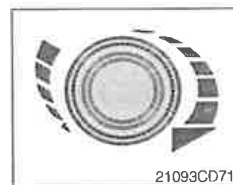

- ① It is possible to search the desired CD track or mp3 file.
 - Turned to clockwise, the CD track or mp3 file number is increased.
 - If it is turned to counterclockwise, CD track or mp3 file number is decreased.
- ※ If a file or track is not selected until 5 seconds, function will be terminated.

(5) Fast rewind/Fast forward button (CD)

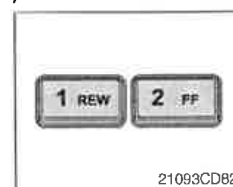

- ① Continually press these button to quickly move rewind or forward through the disc.
- ※ The CD player sound level is lower while press this button.
- ② Normal playback resumes when you release the button.

(6) Random track button (CD)



- ① Press this button to activate random track playback.
- ※ The LCD displays "RDM".
- ② It is canceled press one more this button.

(7) Repeat track button (CD)

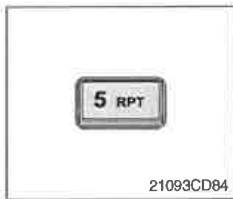

- ① Press this button to activate repeat current track playback.
- ※ The LCD displays "RPT".
- ② It is canceled press one more this button.

(8) Mark button (MP3)



- ① Memory
 - Press over 0.8 second, the current file memorized with a beep (max 100 tune memory).
 - ※ The LCD displays "M" and "Marked number" for 3 seconds.
- ② Memory file playback
 - Press within 0.8 second, the marked file playback.
- ③ Deletion
 - Press over 0.8 second, the marked file will be deleted with a beep.

(9) CD EJECT BUTTON



- ① Press this button to eject the disc.
- ※ If there is no disc in the audio, the LCD displays "NO disc" for 5 seconds.

(10) SCR BUTTON (MP3)

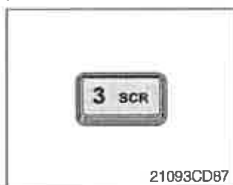

- ① This button to confirm the long file name on LCD.

5) SEAT

The seat is adjustable to fit the contours of the operator's body. It will reduce operator fatigue due to long work hours and enhance work efficiency.

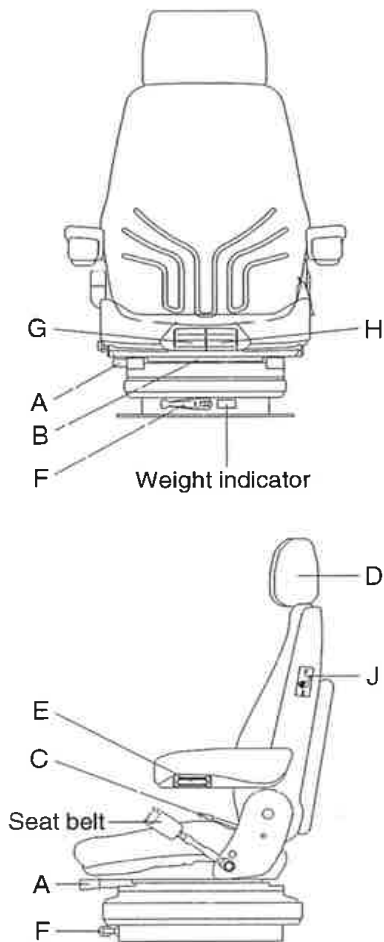

140Z93CD55

(1) Forward/Backward adjustment (A)

- ① Pull lever A to adjust seat forward or backward.
- ② The seat can be moved forward and backward over 130 mm (5.1") in 13 steps.

▲ Do not lift the locking lever with you leg or calf.

(2) Upward/Downward adjustment (B)

- ① Pull lever B to adjust seat upward or downward over 60 mm (2.4").
- ② Forward or backward side adjustment only can be made, tilting to one side, by moving lever B respectively.

(3) Reclining adjustment (C)

Pull lever C to adjust seat back rest.

(4) Armrest adjustment (E)

This can be adjusted by pushing the button E to right and left.

(5) Headrest adjustment (D)

This is adjustable vertically and forward or rearward to fit operator's requirements.

(6) Weight adjustment (F)

Adjust the lever with the seat empty to the operator's weight.

(7) Seat depth adjustment (G)

- ① The depth of the seat pan can be individually adjusted.
- ② To adjust the depth of the seat cushion, pull the right handle upward. By moving the seat cushion backwards or forwards the desired seating position can be reached.

(8) Seat pan angle adjustment (H)

- ① The angle of the seat pan can be individually adjusted.
- ② To adjust the angle of the seat pan, pull the left handle upwards. By exerting pressure on or off the front or rear part of the seat pan it can be moved to the desired position.

(9) Seat heater (J)

The seat heater can be turned on/off by pressing the switch.

0 = Seat heater OFF

1 = Seat heater ON

▲ Always check the condition of the seat belt and mounting hardware before operating the machine.

▲ Replace the seat belt at least once every three years, regardless of appearance.



6) FUSE BOX

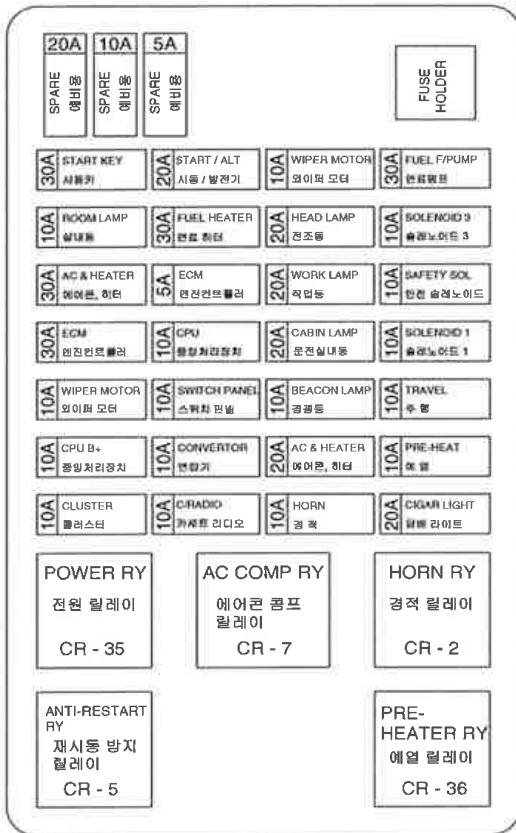

140Z93CD56

(1) The fuses protect the electrical parts and wiring from burning out.

(2) The fuse box cover indicates the capacity of each fuse and circuit it protects.

※ Replace a fuse with another of the same capacity.

▲ Before replacing a fuse, be sure to turn OFF the starting switch.

7) MCU

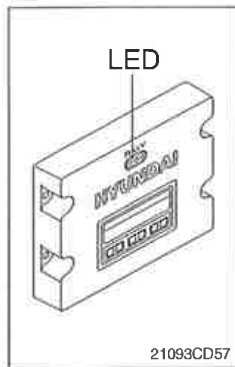

(1) To match the pump absorption torque with the engine torque, MCU varies EPPR valve output pressure, which control pump discharge amount whenever feedbacked engine speed drops under the reference rpm of each mode set.

(2) Three LED lamps on the MCU display as below.

LED lamp	Trouble	Service
G is turned ON	Normal	-
G and R are turned ON	Trouble on MCU	• Change the MCU
G and Y are turned ON	Trouble on serial communication line	• Check if serial communication lines between MCU and cluster are disconnected
Three LED are turned OFF	Trouble on MCU power	• Check if the input power wire (24 V, GND) of MCU is disconnected • Check the fuse

G : green, R : red, Y : yellow

8) EMERGENCY ENGINE SPEED CONTROL CONNECTOR

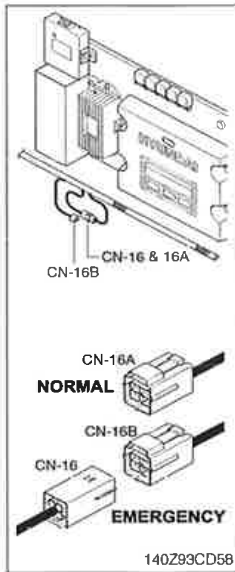

(1) When the CAN communication between the ECM and the MCU is abnormal due to malfunction of the MCU, change CN-16 connection from CN-16A to CN-16B and then control the engine speed by rotating accel dial switch.

※ Never connect connector CN-16 with CN-16B when MCU is in normal operation.

9) SERVICE METER



(1) This meter shows the total operation hours of the machine.

(2) Always ensure the operating condition of the meter during the machine operation. Inspect and service the machine based on hours as indicated in chapter 6, maintenance.

10) RS232 & J1939 SERVICE SOCKET

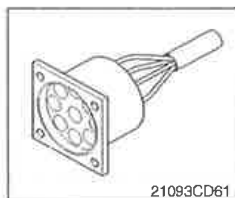

(1) MCU communicates the machine data with Laptop computer through RS232 service socket.

(2) ECM communicates the engine data with Mitsubishi electric tool adapter through J1939 service socket.

- ① ECM fault code check
- ② ECM program change
- ③ Engine data monitoring & test

11) UPPER WINDSHIELD

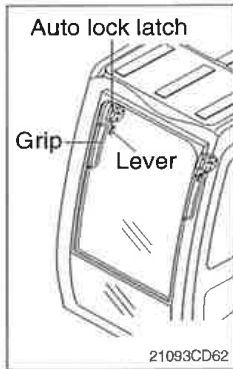

(1) Perform the following procedure in order to open the upper windshield.

- ① Pull both levers with hold both grips that are located at the top of the windshield frame and push the windshield upward.
- ② Hold both grips and back into the lock position until auto lock latch is engaged, then release the lever locked position.



(2) Perform the following procedure in order to close the upper windshield.

- ① Pull the lever of the auto lock latch in order to release the auto lock latch.
- ② Reverse above step ① and ② in order to close the upper windshield.





OPERATION

1. SUGGESTION FOR NEW MACHINE

- 1) It takes about 100 operation hours to enhance its designed performance.
- 2) Operate according to below three steps and avoid excessive operation for the initial 100 hours.

Service meter	Load
Until 10 hours	About 60 %
Until 100 hours	About 80 %
After 100 hours	100 %

※ Excessive operation may deteriorate the potential performance of machine and shorten lifetime of the machine.

3) Be careful during the initial 100 hours operation

- (1) Check daily for the level and leakage of coolant, engine oil, hydraulic oil and fuel.
- (2) Check regularly the lubrication and fill grease daily all lubrication points.
- (3) Tighten bolts.
- (4) Warm up the machine fully before operation.
- (5) Check the gauges occasionally during the operation.
- (6) Check if the machine is operating normally during operation.

4) Replace followings after initial operation hours.

Checking items	Hours
Engine oil	50
Engine oil filter element	
Fuel filter	
Prefilter	
Hydraulic oil return filter element	250
Hydraulic oil tank drain filter cartridge	
Pilot line filter element	
Swing reduction gear oil	500
Travel reduction gear oil	

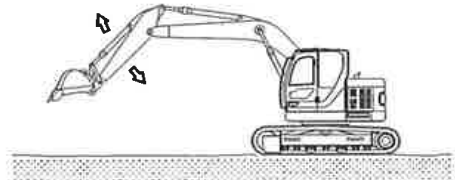

140Z94OP01

2. CHECK BEFORE STARTING THE ENGINE

- 1) Look around the machine and under the machine to check for loosen nut or bolts, collection of dirt, or leakage of oil, fuel or coolant and check the condition of the work equipment and hydraulic system. Check also loosen wiring, and collection of dust at places which reach high temperature.
 ※ Refer to the daily check on the chapter 6, maintenance.
- 2) Adjust seat to fit the contours of the operator's body for the pleasant operation.
- 3) Adjust the rear view mirror.

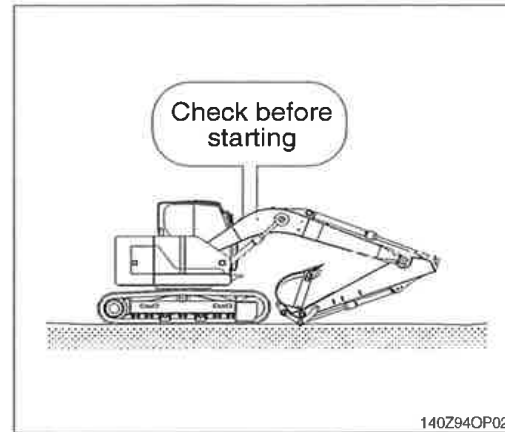

140Z94OP02

3. STARTING AND STOP THE ENGINE

1) CHECK INDICATOR LIGHTS

- (1) Check if all the operating levers are in the neutral position.
- (2) Turn the starting switch to the ON position.
Buzzer sounding for 4 seconds with HYUN-DAI logo on cluster.
- ※ If the ESL mode is set to the enable, enter the password to start engine.
- ※ If the password has failed 5 times, please wait 30 minutes before re-attempting to enter the password.
- ※ Refer to page 3-17 for ESL mode.
- (3) After initialization of cluster, the operating screen is displayed on LCD (1).
Also, self-diagnostic function is carried out.

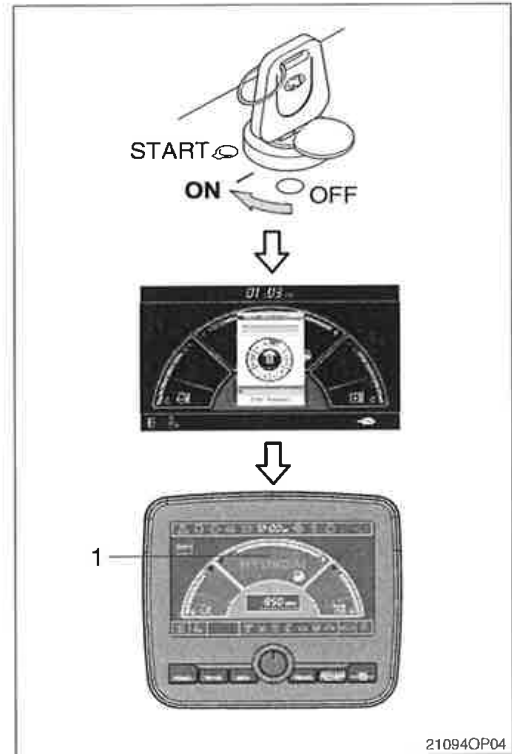

2) STARTING ENGINE IN NORMAL TEMPERATURE

- ※ Sound the horn to warn the surroundings after checking if personnel or obstacles are in the area.
- (1) Turn the starting switch to START position to start the engine.
※ If the engine does not start, allow the starter to cool for about 2 minutes before re-attempting to start the engine again.
 - (2) Release the starting switch instantly after the engine starts to avoid possible damage to the starting motor.

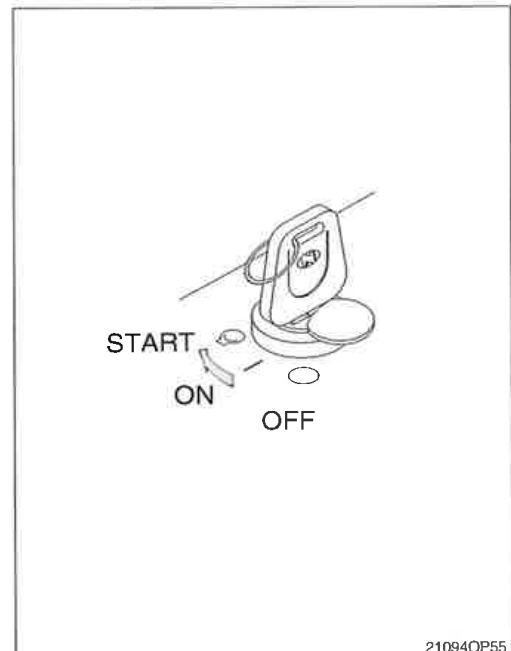



3) STARTING ENGINE IN COLD WEATHER

- ※ Sound horn to warn surroundings after checking if there are obstacles in the area.
- ※ Replace the engine oil and fuel referring to recommended oils at page 2-28.
- ※ Fill the anti-freeze solution to the coolant as required.
- ※ If you turn ON the starting switch, the fuel warmer is automatically operated to heat the fuel by sensing the coolant temperature.

- (1) Check if all the levers are in the neutral position.
- (2) Turn the starting switch to the ON position, and wait 1~2 minutes. More time may take according to ambient temperature.
- (3) Start the engine by turning the starting switch to the START position after the preheat pilot lamp OFF.
- ※ If the engine does not start, allow the starter to cool for about 2 minutes before attempting to start the engine again.
- (4) Release the starting switch immediately after starting engine.
- (5) The operation for warming up machine is automatic.

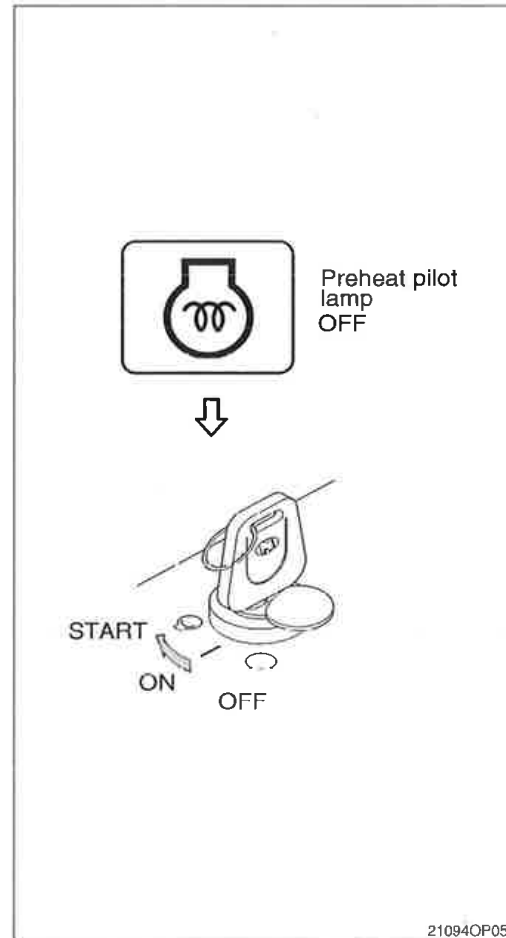

4) INSPECTION AFTER ENGINE START

Inspect and confirm the following after engine starts.

- (1) Is the level gauge of hydraulic oil tank in the normal level?
- (2) Are there leakages of oil or water?
- (3) Are all the warning lamps turned OFF (1~9)?
- (4) Are the indicator of water temperature gauge (10) and hydraulic temperature gauge (11) in the operating range?
- (5) Are the engine sound and the color of exhaust gas normal?
- (6) Are the sound and vibration normal?
- ※ Do not increase engine speed quickly after starting, it can damage engine or turbocharger.
- ※ If there are problems in the cluster, stop the engine immediately and correct problems as required.

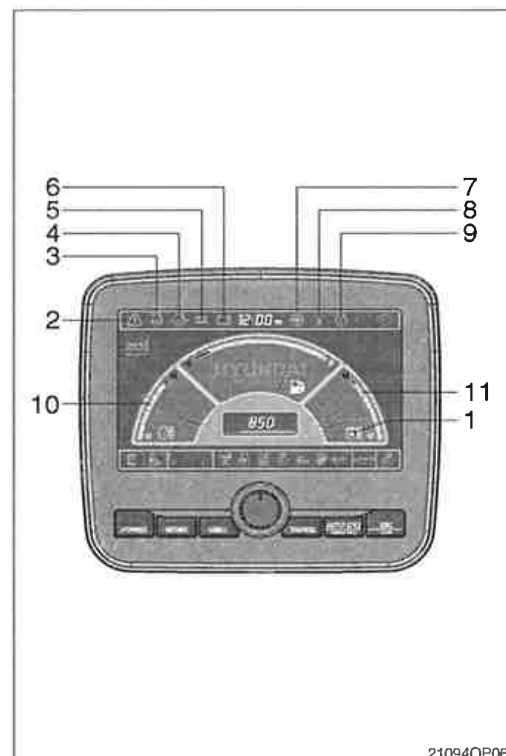

5) WARMING-UP OPERATION

※ The most suitable temperature for the hydraulic oil is about 50°C (122°F).

It can cause serious trouble in the hydraulic system by sudden operation when the hydraulic oil temperature is below 25°C (77°F).

Then temperature must be raised to at least 25°C (77°F) before starting work.

- (1) Run the engine at low idle speed for 5 minutes.
- (2) Speed up the engine by accel dial and run the engine at mid-range speed.
- (3) Operate bucket lever for 5 minutes.
※ Do not operate anything except bucket lever.
- (4) Run the engine at the high speed and operate the bucket lever and arm lever for 5-10 minutes.
※ Operate only the bucket lever and arm lever.
- (5) This warming-up operation will be completed by operation of all cylinders several times, and operation of swing and traveling.
※ Increase the time for warming-up during winter.

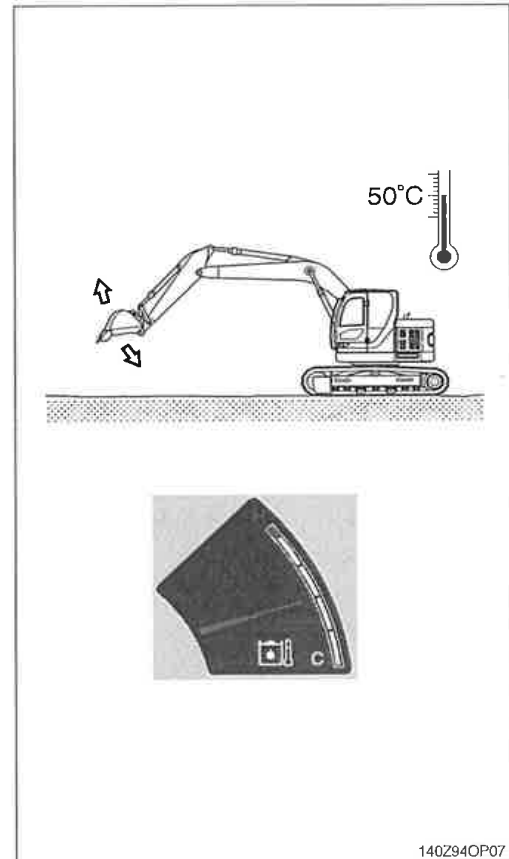

6) TO STOP THE ENGINE

※ If the engine is abruptly stopped before it has cooled down, engine life may be greatly shortened. Consequently, do not abruptly stop the engine apart from an emergency.

※ In particular, if the engine has overheated, do not abruptly stop it but run it at medium speed to allow it to cool gradually, then stop it.

- (1) Down the bucket on the ground then put all the levers in the neutral position.
- (2) Run the engine at low idle speed for about 5 minutes.
- (3) Return the key of starting switch to the OFF position.
- (4) Remove the key to prevent other people using the machine and LOCK safety lever.
- (5) Lock the cab door.

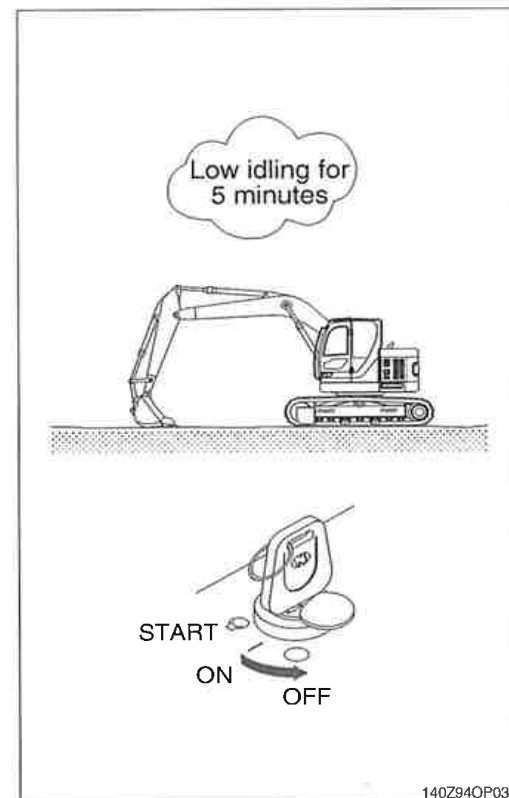



4. MODE SELECTION SYSTEM

1) STRUCTURE OF MECHATRONICS SYSTEM

CAPO, Computer Aided Power Optimization system, is the name of mode selection system developed by Hyundai.

※ Please refer to chapter 3, cluster for below modes setting.

(1) Power mode

Power mode designed for various work loads supports high performance and reduces fuel consumption.

- P mode : Heavy duty power
- S mode : Standard power
- E mode : Economy power

(2) Work mode

One of the two work modes can be selected for the optimal work condition of the machine operation.

① General work mode (bucket)

When key switch is turned ON, this mode is selected automatically.

② Work tool mode (breaker, crusher)

It controls the pump flow and system pressure for the optimal operation of breaker or crusher.

(3) User mode

① User mode is useful for setting the user preferable power quickly.

(engine speed, power shift and idle speed)

② There are two methods for use of user mode.

a. In operation screen

User mode switch is used to memorize the current machine operating status and activate the memorized user mode.

Refer to page 3-10.

b. In menu

Engine high idle rpm, auto idle rpm and pump torque (power shift) can be modulated and memorized separately in menu status.

- Each memory mode has a initial set which are mid-range of max engine speed, power shift and auto idle speed.

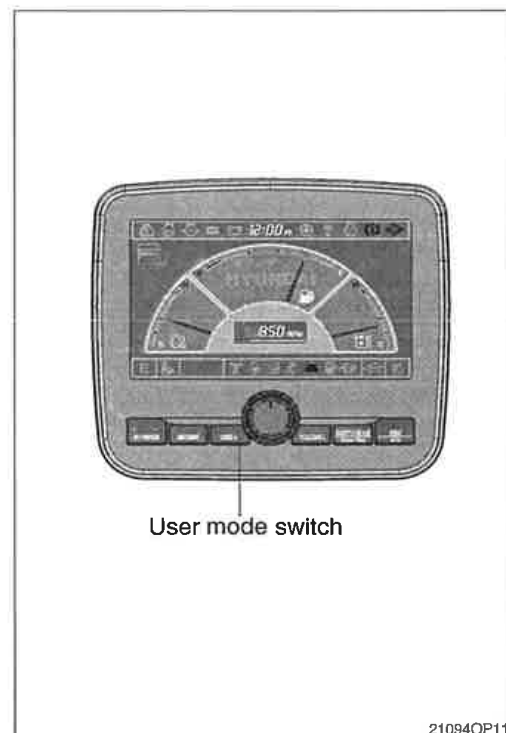
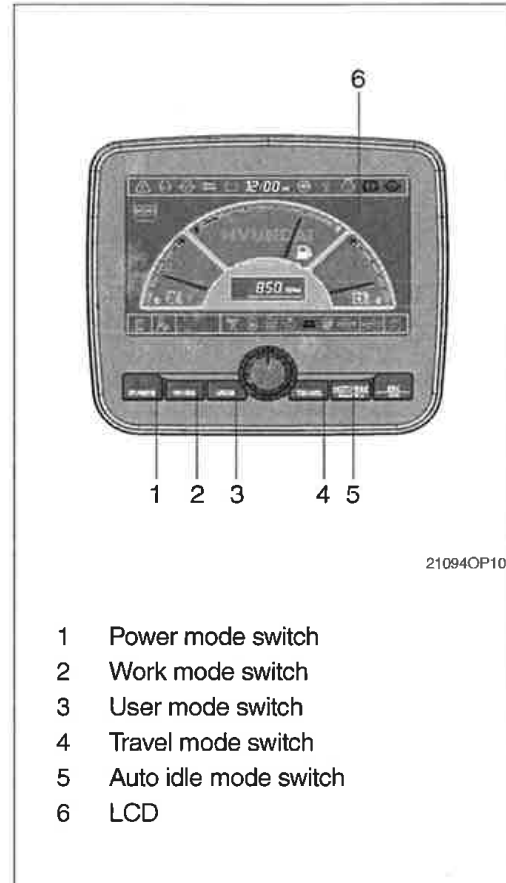



- High idle rpm, auto idle rpm and EPPR pressure can be adjusted and memorized in the U-mode.
- ※ Refer to the page 3-12 for setting the user mode (available on U mode only).

· LCD segment vs parameter setting

Step ()	Engine speed (rpm)	Idle speed (rpm)	Power shift (bar)
1	1550	800	0
2	1600	850	3
3	1650	900 (low idle)	6
4	1700	950	9
5	1750	1000 (decel rpm)	12
6	1800	1050	16
7	1850	1100	20
8	1900	1150	26
9	1950	1200	32
10	2000	1250	38



21094OP12

(4) Travel mode

- : Low speed traveling.
- : High speed traveling.

(5) Auto idle mode

- Pilot lamp ON : Auto idle function is activated.
- Pilot lamp OFF : Auto idle function is canceled.



(6) Monitoring system

Information of machine performance as monitored by the MCU can be displayed on the LCD. Refer to the page 3-11.

(7) Self diagnostic system

① **MCU (Machine Control Unit)**

The MCU diagnoses machine status and problems and displays fault code in the cluster (fault code detected by MCU is composed of HCESPN and FMI).

② **Engine ECM (Electronic Control Module)**

If the engine or relevant system has problem, engine ECM detects and displays on the LCD as fault codes (this code is composed of SPN and FMI).

※ Refer to the page 3-11 for LCD display.

(8) Anti-restart system

The system protects the starter from inadvertent restarting after the engine is already operational.

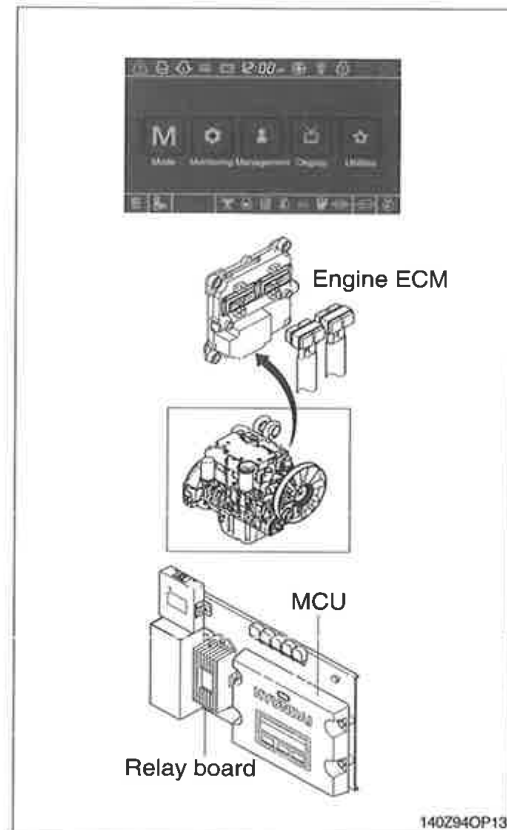

140Z94OP13

2) HOW TO OPERATE MODE SELECTION SYSTEM

(1) When start key switch is turned ON

- ① When start key switch is turned on, the cluster turns on and buzzer sounds for 4 seconds. And then main information as gauges and engine speed are displayed on LCD.
- ② Initial default mode settings are displayed in the cluster.

Mode		Status
Power mode	E	ON
Work mode		ON
Travel mode	Low (ON
Auto decel		ON

※ These setting can be changed at U mode.

- ③ Self-diagnostic function can be carried out from this point.

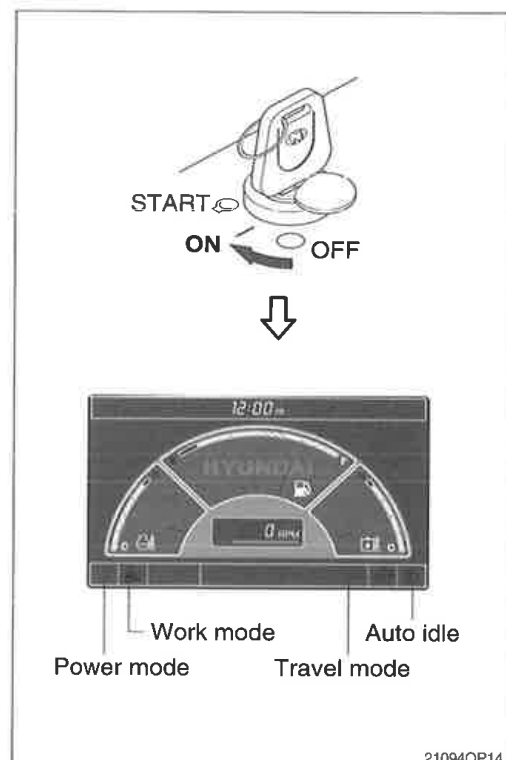

21094OP14



(2) After engine start

- ① When the engine is started, rpm display indicates low idle, 900 ± 100 rpm.
- ② If coolant temperature is below 30°C , the warming up pilot lamp lights ON and after 4 seconds the engine speed increases to 1000 ± 100 rpm automatically to warm up the machine.
 - After 2-3 minutes, you can select any mode depending on job requirement.

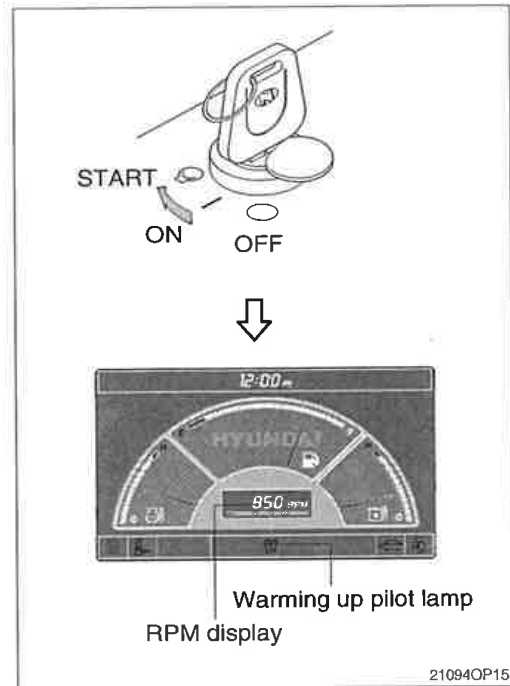

21094OP15

3) SELECTION OF POWER MODE

(1) E mode

The accel dial is set 10 and the auto idle mode is canceled.

Engine rpm	Effect
1650 ± 50	Variable power control in proportion to lever stroke (improvement in fuel efficiency) ※ Same power as S mode in full lever operation.

※ When the accel dial is located below 9 the engine speed decreases about 50~100 rpm per dial set.

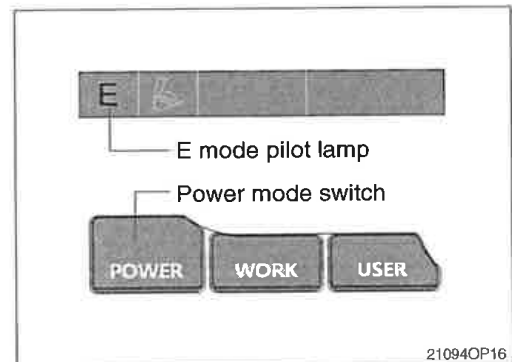

21094OP16

(2) S mode

The accel dial is set 10 and the auto idle mode is canceled.

Engine rpm	Effect
1800 ± 50	Standard power

※ When the accel dial is located below 9 the engine speed decreases about 50~100 rpm per dial set.

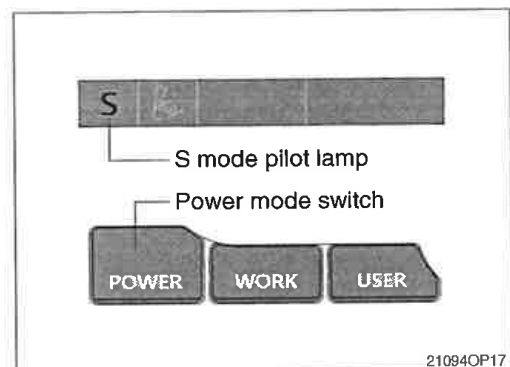

21094OP17



(3) P mode

The accel dial is set 10 and the auto idle mode is canceled.

Engine rpm	Effect
2000 ± 50	Approximately 120 % of power and speed available than S mode.

※ When the accel dial is located below 9 the engine speed decreases about 50~100 rpm per dial set.

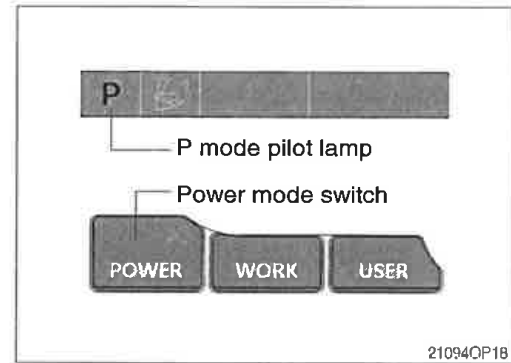

5. OPERATION OF THE WORKING DEVICE

※ Confirm the operation of control lever and working device.

- 1) Left control lever controls arm and swing.
- 2) Right control lever controls boom and bucket.
- 3) When you release the control lever, control lever returns to neutral position automatically.

※ When operating swing, consider the swing distance by inertia.

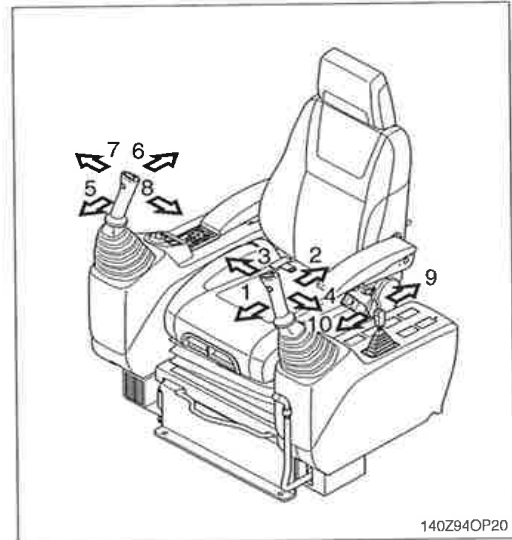

※ Left control lever

- 1 Arm roll-out
- 2 Arm roll-in
- 3 Swing right
- 4 Swing left

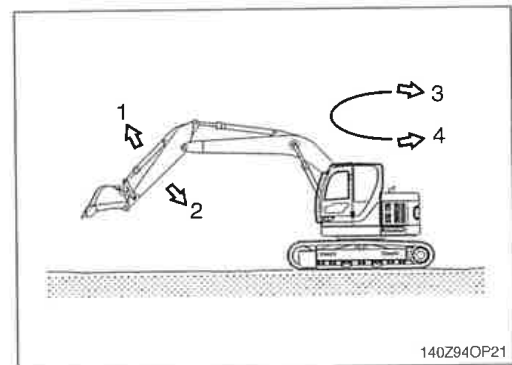

※ Right control lever

- 5 Boom lower
- 6 Boom raise
- 7 Bucket roll-out
- 8 Bucket roll-in

※ Dozer blade control lever

- 9 Dozer blade up
- 10 Dozer blade down

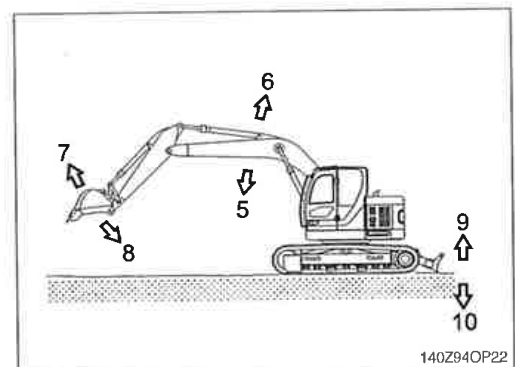

6. TRAVELING OF THE MACHINE

1) BASIC OPERATION

(1) Traveling position

It is the position which the traveling motor is in the rear and the working device is forward.

- ▲ **Be careful as the traveling direction will be reversed when the whole machine is swunged 180 degree.**

(2) Traveling operation

It is possible to travel by either travel lever or pedal.

- ※ **Do not travel continuously for a long time.**
- ※ **Reduce the engine speed and travel at a low speed when traveling on uneven ground.**

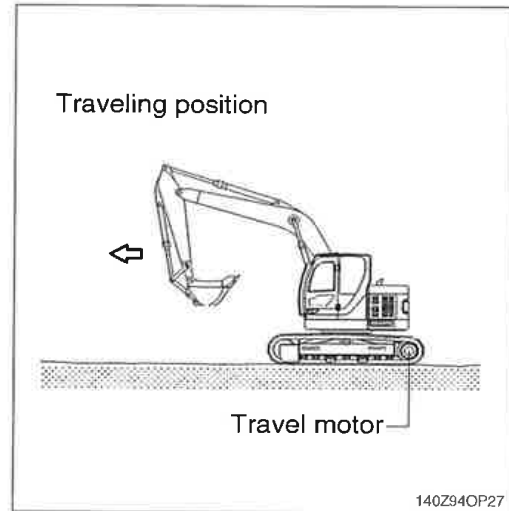

(3) Forward and backward traveling

When the left and right travel lever or pedal are pushed at the same time, the machine will travel forward or backward.

- ※ **The speed can be controlled by the operation stroke of lever or pedal and change of direction will be controlled by difference of the left and right stroke.**

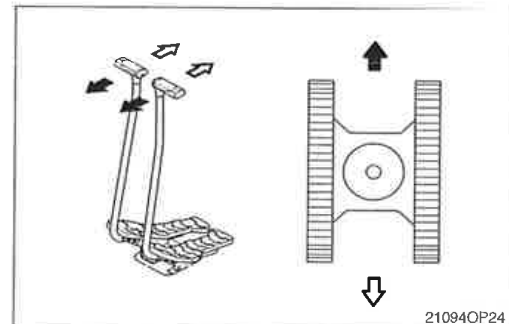

(4) Pivot turning

Operating only one side of lever or pedal make the change of direction possible by moving only one track.

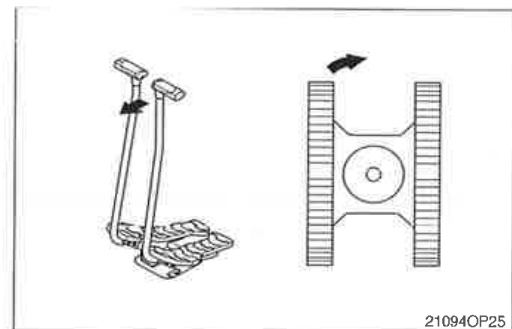

(5) Counter rotation

It is to change the direction at the original place by moving the right and left track. Both side of lever or pedal are operated to the other way at the same time.

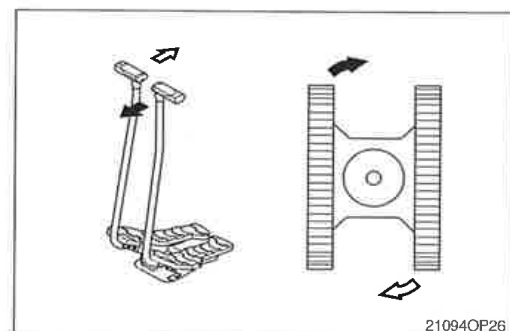

2) TRAVELING ON A SLOPE

- (1) Make sure that the travel lever is properly maneuvered by confirming the travel motor is in the right location.
 - (2) Lower the bucket 20 to 30 cm (1 ft) to the ground so that it can be used as a brake in an emergency.
 - (3) If the machine starts to slide or loses stability, lower the bucket immediately and brake the machine.
 - (4) When parking on a slope, use the bucket as a brake and place blocks behind the tracks to prevent sliding.
- ※ Machine cannot travel effectively on a slope when the oil temperature is low. Do the warming-up operation when it is going to travel on a slope.
- ⚠ Be careful when working on slopes. It may cause the machine to lose its balance and turn over.
- ⚠ Be sure to keep the travel speed switch on the LOW (turtle mark) while traveling on a slope.

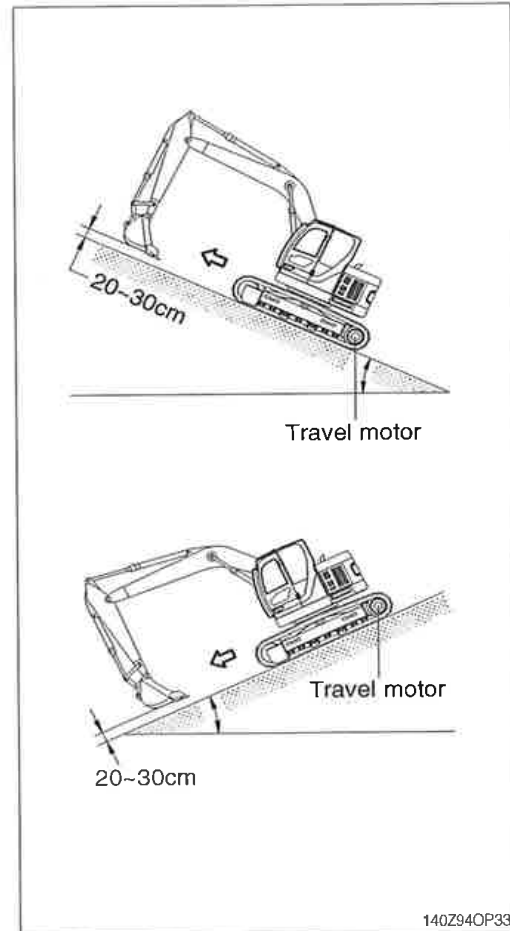

3) TRAVELING ON SOFT GROUND

- ※ If possible, avoid to operate on soft ground.
- (1) Move forward as far as machine can move.
 - (2) Take care not to go beyond the depth where towing is impossible on soft ground.
 - (3) When driving becomes impossible, lower bucket and use boom and arm to pull the machine. Operate boom, arm, and travel lever at the same time to avoid the machine sinking.

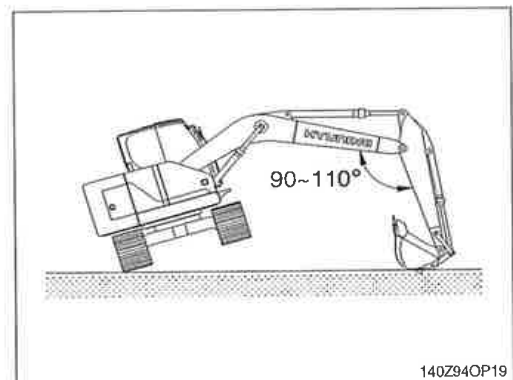



4) TOWING THE MACHINE

Tow the machine as follows when it can not move on it's own.

- (1) Tow the machine by other machine after hook the wire rope to the frame as shown in picture at right.
 - (2) Hook the wire rope to the frame and put a support under each part of wire rope to prevent damage.
- ※ **Never tow the machine using only the tie hole, because this may break.**
 - ▲ **Make sure no personnel are standing close to the tow rope.**

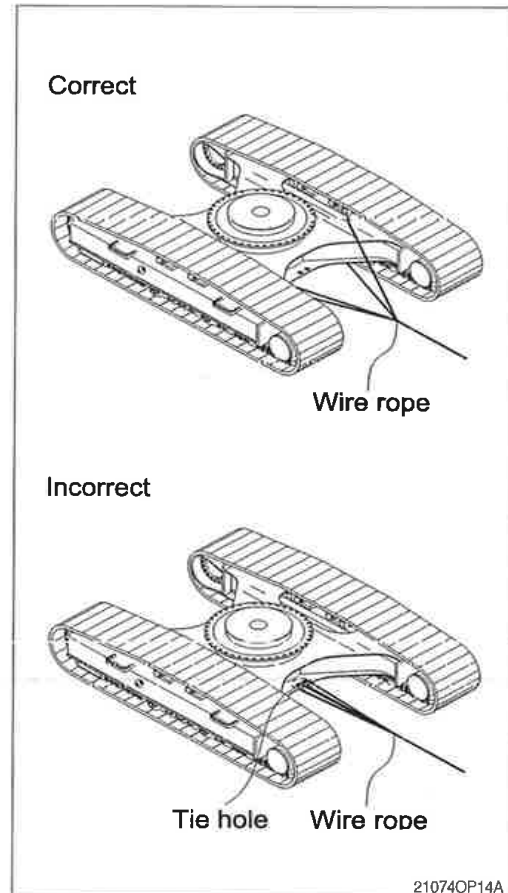

7. EFFICIENT WORKING METHOD

- 1) Do the digging work by arm.

Use the pulling force of arm for digging and use together with the digging force of the bucket if necessary.

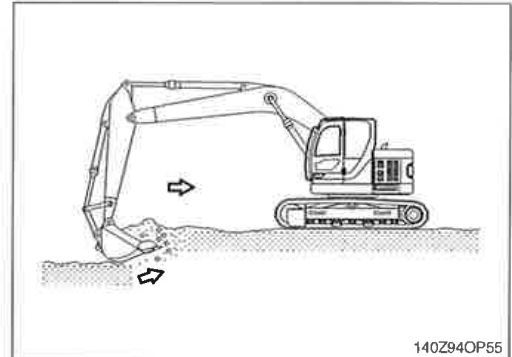

- 2) When lowering and raising the boom operate softly for the beginning and the end.

In particularly, sudden stops while lowering the boom may cause damage to the machine.

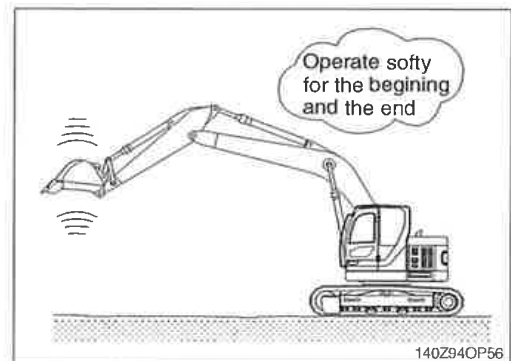

- 3) The digging resistance and wearing of tooth can be reduced by putting the end of bucket tooth to the digging direction.

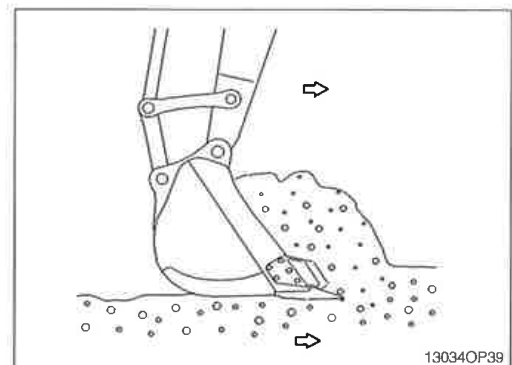

- 4) Set the tracks parallel to the line of the ditch to be excavated when digging ditch. Do not swing while digging.

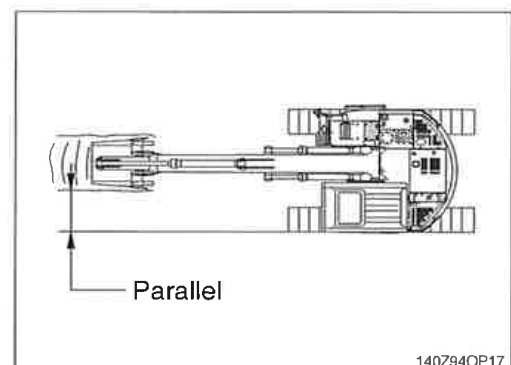

- 5) Dig slowly with keeping the angle of boom and arm, 90-110 degree when maximum digging force is required.

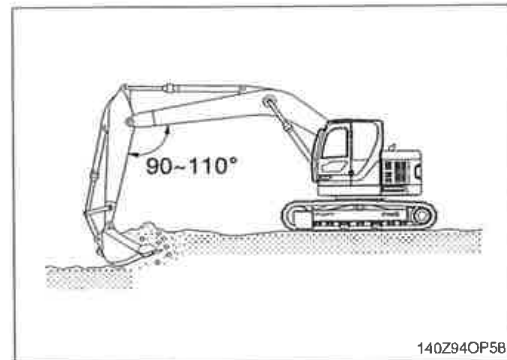

- 6) Operate leaving a small safety margin of cylinder stroke to prevent damage of cylinder when working with the machine.

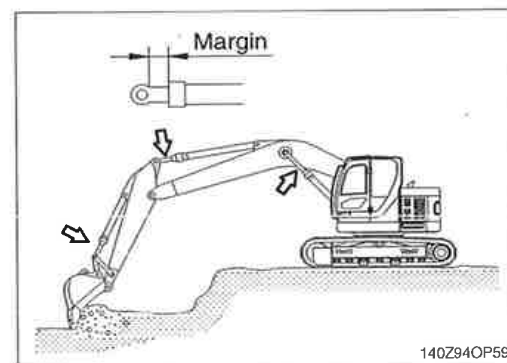

- 7) Keep the bucket to the dumping position and the arm horizontal when dumping the soil from the bucket.
Operate bucket lever 2 or 3 times when hard to dump.

※ Do not use the impact of bucket tooth when dumping.

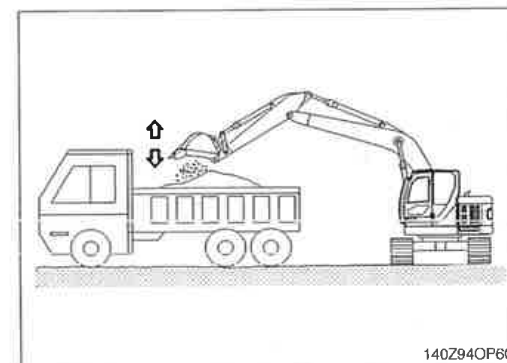

- 8) Operate stop of swing considering the swing slip distance is created by inertia after neutralizing the swing lever.

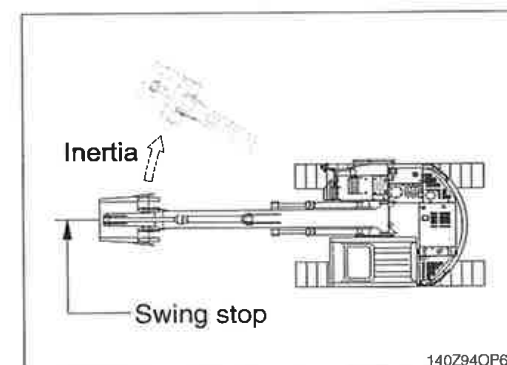

- 9) If the excavation is in an underground location or in a building, make sure that there is adequate overhead clearance and that there is adequate ventilation.

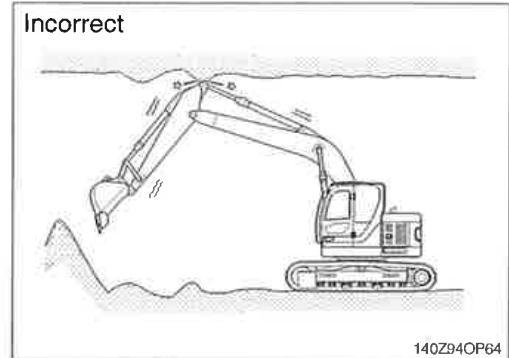

- 10) Do not use the dropping force of the work equipment for digging.
The machine can be damaged by the impact.

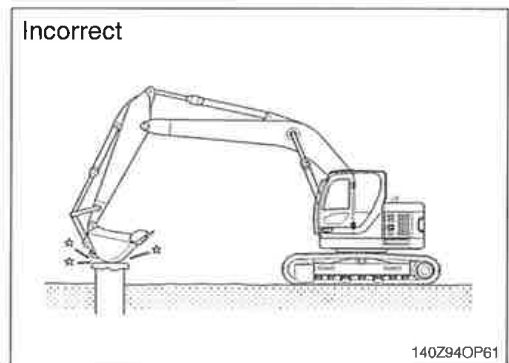

- 11) Do not use the bucket to crack hard objects like concrete or rocks.
This may break a tooth or pin, or bend boom.

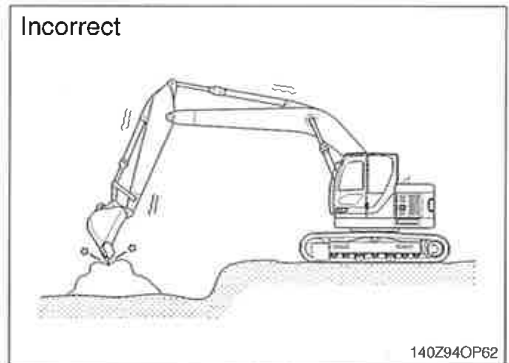

- 12) NEVER CARRY OUT EXCESSIVE OPERATIONS
Operation exceeding machine performance may result in accident or failure.
Carry out lifting operation within specified load limit.
Never carry out operations which may damage the machine such as overload or over-impact-load.
Never travel while carrying a load.
In case you need installing over load warning device for object handling procedure, please contact Hyundai distributor.

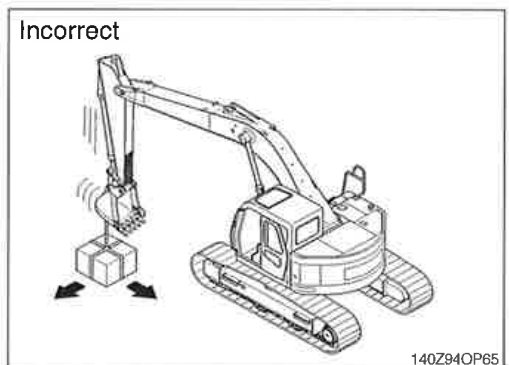

12) BUCKET WITH HOOK

When carrying out lifting work, the special lifting hook is necessary.

The following operations are prohibited.

- Lifting loads with a wire rope fitted around the bucket teeth.
- Lifting loads with the wire rope wrapped directly around the boom or arm.

When performing lifting operation, securely hook the wire rope onto the special lifting hook.

When performing lifting operation, never raise or lower a person.

Due to the possible danger of the load falling or of collision with the load, no persons shall be allowed in the working area.

Before performing lifting operation, designate an operation supervisor.

Always execute operation according to his instructions.

- Execute operating methods and procedures under his direction.
- Select a person responsible for signaling. Operate only on signals given by such person.

Never leave the operator's seat while lifting a load.

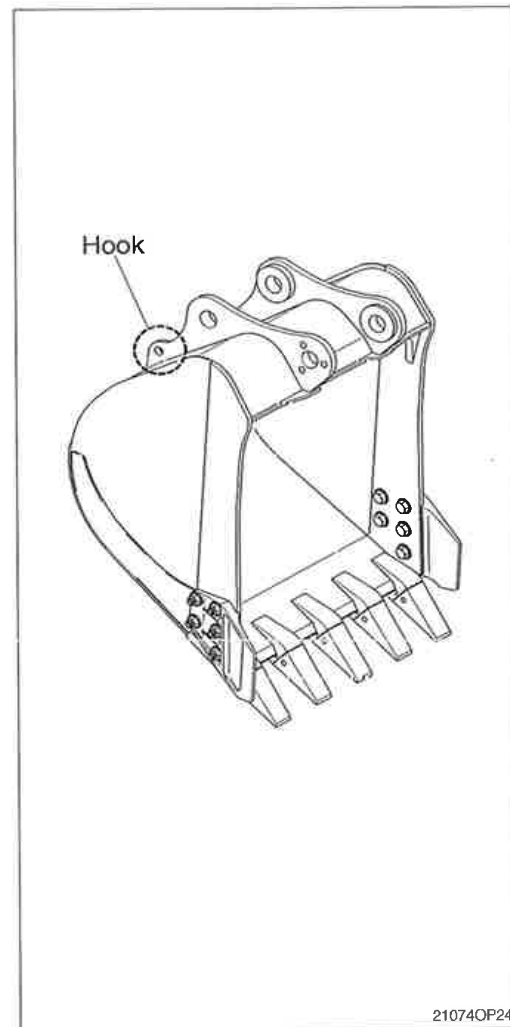

21074OP24

8. OPERATION IN THE SPECIAL WORK SITES

1) OPERATION THE MACHINE IN A COLD WEATHER

- (1) Use proper engine oil and fuel for the weather.
- (2) Fill the required amount of antifreeze in the coolant.
- (3) Refer to the starting engine in cold weather.
Start the engine and extend the warming up operation.
- (4) Be sure to open the heater cock when using the heater.
- (5) Always keep the battery completely charged.
※ **Discharged batteries will freeze more easily than fully charged.**
- (6) Clean the machine and park on the wood plates.

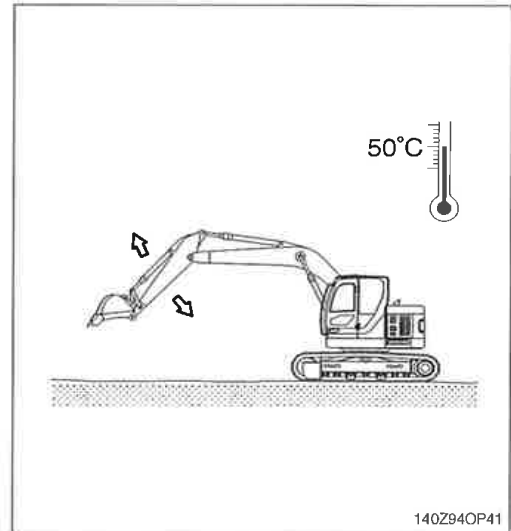

2) OPERATION IN SANDY OR DUSTY WORK SITES

- (1) Inspect air cleaner element frequently. Clean or replace element more frequently, if warning lamp comes ON and buzzer sounds simultaneously, regardless of inspection period.
※ **Replace the inner and outer element after 6 times of cleaning.**
- (2) Inspect radiator frequently, and keep cooling fins clean.
- (3) Prevent sand or dust from getting into fuel tank and hydraulic tank during refilling.
- (4) Prevent sand or dust from penetrating into hydraulic circuit by tightly closing breather cap of hydraulic oil tank. Replace hydraulic oil filter frequently.
- (5) Keep all lubricated part, such as pins and bushings, clean at all times.
- (6) If the air conditioner and heater filters clogged, the heating or cooling capacity will drop. Clean or replace the filter element more frequently.



3) SEA SHORE OPERATION

- (1) Prevent ingress of salt by securely tightening plugs, cocks and bolts of each part.
- (2) Wash machine after operation to remove salt residue.
Pay special attention to electrical parts, and hydraulic cylinders and track tension cylinder to prevent corrosion.
- (3) Inspection and lubrication must be carried out more frequently.
Supply sufficient grease to replace all old grease in bearings which have been submerged in water for a long time.

4) OPERATION IN MUD, WATER OR RAIN WORK SITES

- (1) Perform a walk around inspection to check for any loose fittings, obvious damage to the machine or any fluid leakage.
- (2) After completing operations, clean mud, rocks or debris from the machine. Inspect for damage, cracked welds or loosened parts.
- (3) Perform all daily lubrication and service.
- (4) If the operations were in salt water or other corrosive materials, make sure to flush the affected equipment with fresh water.

9. NORMAL OPERATION OF EXCAVATOR

Followings may occur during operation due to the nature of a hydraulic excavator.

- 1) When rolling in the arm, the roll-in movement stop momentary at point X in the picture shown, then recovers speed again after passing point X.
The reason for this phenomenon is that movement by the arm weight is faster than the speed of oil flow into the cylinder.
- 2) When lowering the boom, one may hear continuous sound.
This is caused by oil flow in the valve.
- 3) Overloaded movement will produce sound caused by the relief valves, which are for the protection of the hydraulic systems.
- 4) When the machine is started swing or stopped, a noise near the swing motor may be heard. The noise is generated when the brake valve relieves.

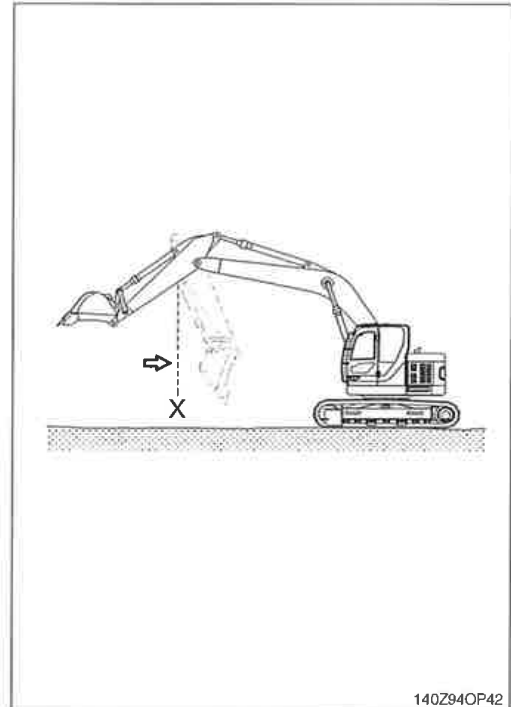

140Z94OP42

10. ATTACHMENT LOWERING (when engine is stopped)

1) On machines equipped with an accumulator, for a short time (within 1 minute) after the engine is stopped, the attachment will lower under its own weight when the attachment control lever is shifted to LOWER. That is happen only starting switch ON position and safety lever UNLOCK position. After the engine is stopped, set the safety lever to the LOCK position.

⚠ Be sure no one is under or near the attachment before lowering the boom.

2) The accumulator is filled with high-pressure nitrogen gas, and it is extremely dangerous if it is handled in the wrong way. Always observe the following precautions.

⚠ Never make any hole in the accumulator expose it to flame or fire.

⚠ Do not weld anything to the accumulator.

※ When carrying out disassembly or maintenance of the accumulator, or when disposing of the accumulator, it is necessary to release the gas from the accumulator.

A special air bleed valve is necessary for this operation, so please contact your Hyundai distributor.

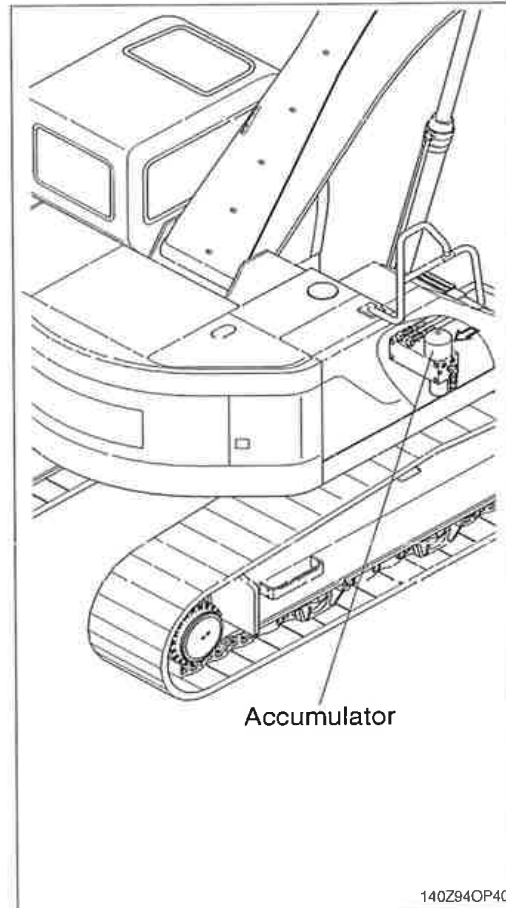

140Z94OP40



11. STORAGE

Maintain the machine taking care of following to prevent the deterioration of machine when storing the machine for a long time, over 1 month.

1) CLEANING THE MACHINE

Clean the machine. Check and adjust tracks.
Grease each lubrication part.

2) LUBRICATION POSITION OF EACH PART

Change all oil.

※ Be particularly careful when you reuse the machine.

As oil can be diluted during storage.

Apply an anticorrosive lubricant on the exposed part of piston rod of cylinder and in places where the machine rusts easily.

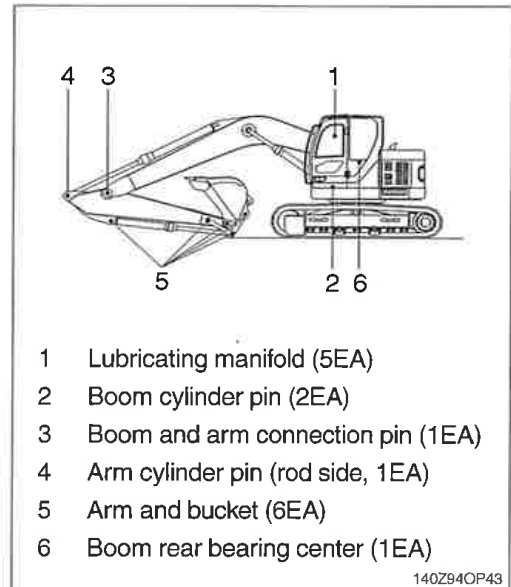

3) MASTER SWITCH

Turn OFF the master switch mounted electric box and store the machine.

4) Be sure to mix anticorrosive antifreezing solution in the radiator.

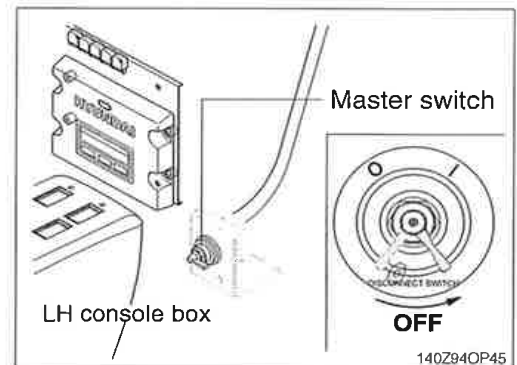

5) PREVENTION OF DUST AND MOISTURE

Keep machine dry. Store the machine setting wood on the ground.

※ Cover exposed part of piston rod of cylinder.

※ Lower the bucket to the ground and set a support under track.

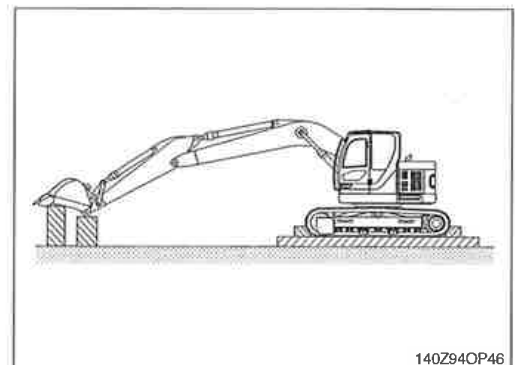



6) DURING STORAGE

Start engine and move the machine and work equipment once a month and apply lubrication to each part.

- ※ Check the level of engine oil and coolant and fill if required when starting engine.
- ※ Clean the anticorrosive on the piston rod of cylinder.
- ※ Operate the machine such as traveling, swing and work equipment operation to make sure enough lubrication of all functional components.

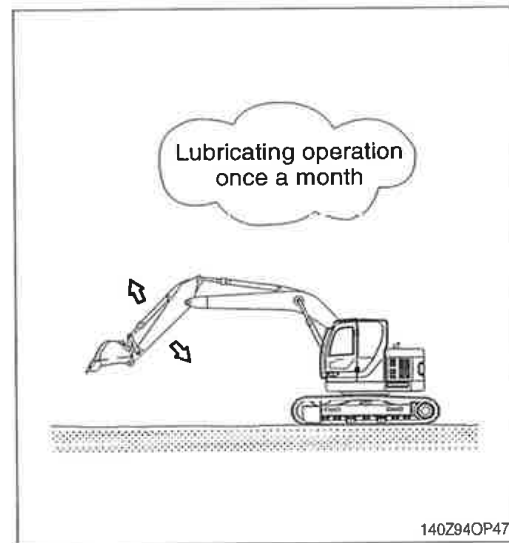



12. RCV LEVER OPERATING PATTERN

1) PATTERN CHANGE VALVE NOT INSTALL (standard)

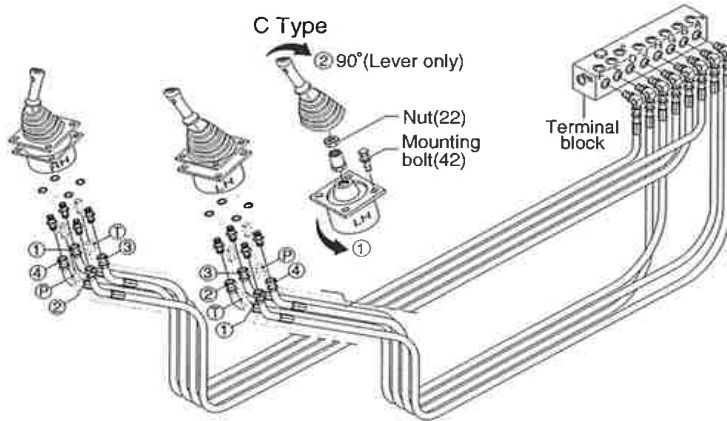

※ Whenever a change is made to the machine control pattern also exchange the pattern label in the cab to match the new pattern.

21094OP50

Pattern	Operation		Control function	Hose connection (port)			
	Left RCV lever	Right RCV lever		RCV lever	Change of Terminal block		
					From	To	
ISO Type			Left	1 Arm out	②	D	-
				2 Arm in	④	E	-
				3 Swing right	③	B	-
				4 Swing left	①	A	-
	Hyundai		Right	5 Boom lower	④	J	-
				6 Boom raise	②	H	-
				7 Bucket out	①	G	-
				8 Bucket in	③	F	-
A Type			Left	1 Boom lower	②	D	J
				2 Boom raise	④	E	H
				3 Swing right	③	B	-
				4 Swing left	①	A	-
	Right	5 Arm out	④	J	D		
		6 Arm in	②	H	E		
		7 Bucket out	①	G	-		
		8 Bucket in	③	F	-		
B Type			Left	1 Boom lower	②	D	J
				2 Boom raise	④	E	H
				3 Bucket in	③	B	F
				4 Bucket out	①	A	G
	Right	5 Arm out	④	J	D		
		6 Arm in	②	H	E		
		7 Swing right	①	G	B		
		8 Swing left	③	F	A		
C Type			Left	① Loosen the RCV lever mounting bolt (42) and rotates lever assy 90° counterclockwise; then install. ② To put lever in correct position, disassemble nut (22) and rotates only lever 90° clockwise.			
			Right	Same as ISO type			



2) PATTERN CHANGE VALVE INSTALL (option)

- ※ If the machine is equipped with the pattern change valve, the machine operation pattern can be easily changed.
- ※ Whenever a change is made to the machine control pattern also exchange the pattern label in the cab to match the new pattern.

Operation	ISO type	A type
Left RCV lever		
Right RCV lever		

(1) The machine control pattern can be easily changed from the "ISO type" to "A type" by changing the position of the lever.

- ▲ Before starting the machine, check the lever position of pattern change valve and actual operating of attachment.

(2) Change of operating pattern

- ① Loosen the bolt (11).
- ② Move lever from the "ISO type" to "A type" position.
- ③ After the lever is set, tighten the bolt in order to secure the lever.

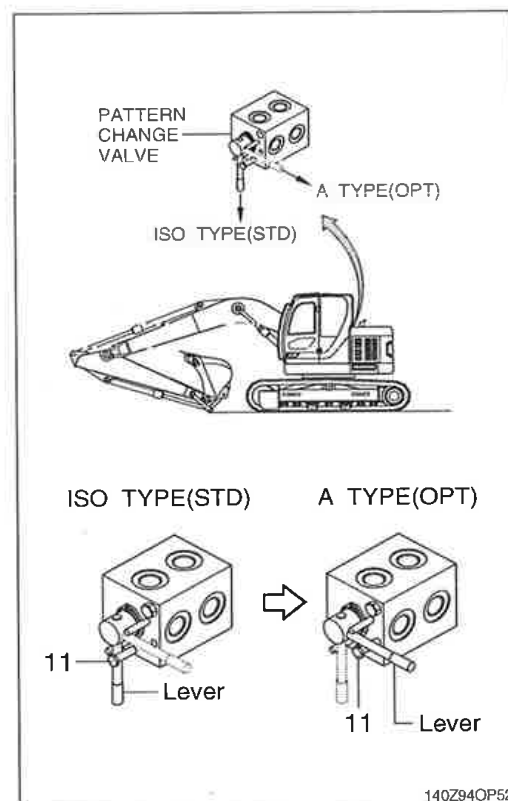

140Z94OP52

13. SWITCHING HYDRAULIC ATTACHMENT CIRCUIT

- 1) The combined hydraulic attachment circuit is capable of providing single action or double action.
- 2) The position of 3 way valve selects the single action hydraulic attachment circuit or the double action hydraulic attachment circuit.
- 3) Before you change the flow mode of hydraulic attachment circuit, place the machine in the servicing position as shown. Stop the engine.

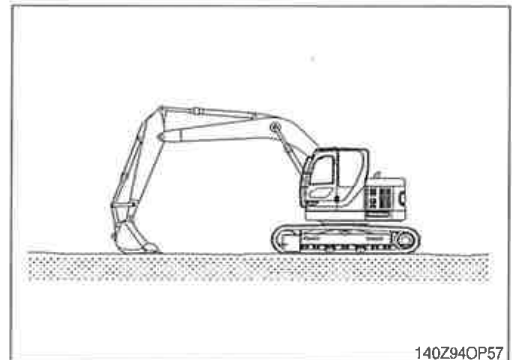

- 4) Use the spanner to turn the bolt of 3 way valve. Make sure that you turn the bolt between (b) and (c).

 - (1) **One way flow** (hydraulic breaker)
Position the groove parallel to the piping (b).
 - (2) **Two way flow** (clamshell or shear)
Position the groove perpendicular to the piping (c).

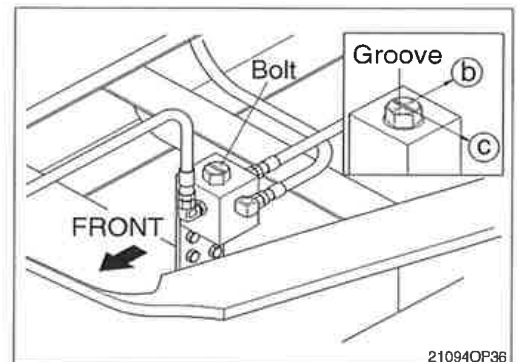





TRANSPORTATION

1. PREPARATION FOR TRANSPORTATION

- 1) When transporting the machine, observe the various road rules, road transportation vehicle laws and vehicle limit ordinances, etc.
- 2) Select proper trailer after confirming the weight and dimension from the chapter 2, specification.
- 3) Check the whole route such as the road width, the height of bridge and limit of weight and etc., which will be passed.
- 4) Get the permission from the related authority if necessary.
- 5) Prepare suitable capacity of trailer to support the machine.
- 6) Prepare gangplank for safe loading referring to the below table and illustration.

A	B
1.0	3.65 ~ 3.85
1.1	4.00 ~ 4.25
1.2	4.35 ~ 4.60
1.3	4.75 ~ 5.00
1.4	5.10 ~ 5.40
1.5	5.50 ~ 5.75

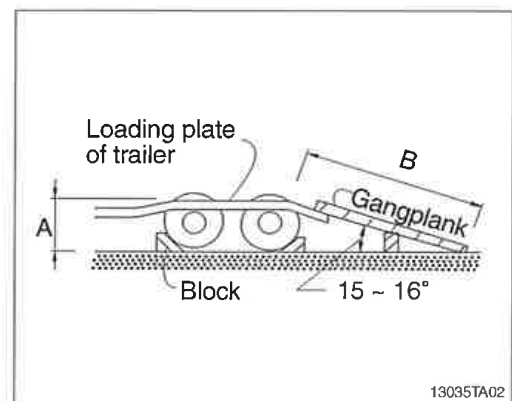
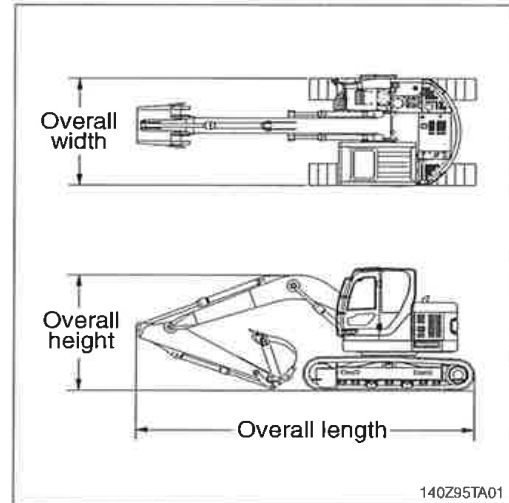



2. DIMENSION AND WEIGHT

1) BASE MACHINE (R145CR-9)

Mark	Description	Unit	Specification
L	Length	mm (ft-in)	3640 (11' 11")
H	Height	mm (ft-in)	2900 (9' 6")
W	Width	mm (ft-in)	2500 (8' 2")
Wt	Weight	kg (lb)	12180 (26850)

※ With 500 mm (20") triple grouser shoes and 2800 kg (6170 lb) counterweight.

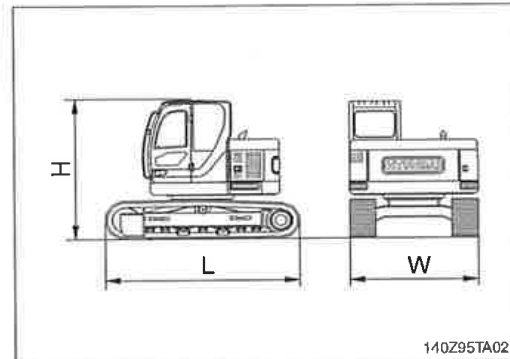

2) BASE MACHINE (R145CRD-9)

Mark	Description	Unit	Specification
L	Length	mm (ft-in)	4190 (13' 9")
H	Height	mm (ft-in)	2900 (9' 6")
W	Width	mm (ft-in)	2500 (8' 2")
Wt	Weight	kg (lb)	12980 (28620)

※ With 500 mm (20") triple grouser shoes and 2800 kg (6170 lb) counterweight.

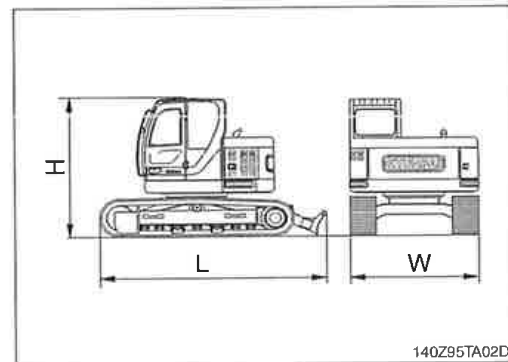

3) BOOM ASSEMBLY

Mark	Description	Unit	Specification
L	Length	mm (ft-in)	4750 (15' 7")
H	Height	mm (ft-in)	1340 (4' 5")
W	Width	mm (ft-in)	520 (1' 8")
Wt	Weight	kg (lb)	1020 (2250)

※ 4.6 m (15' 1") boom with arm cylinder (Included piping and pins).

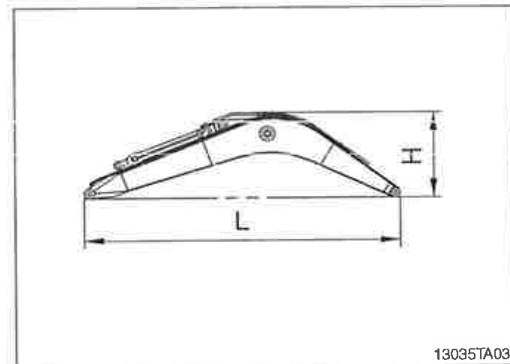

4) ARM ASSEMBLY

Mark	Description	Unit	Specification
L	Length	mm (ft-in)	3240 (10' 8")
H	Height	mm (ft-in)	740 (2' 5")
W	Width	mm (ft-in)	380 (1' 3")
Wt	Weight	kg (lb)	620 (1370)

※ 2.50 m (8' 2") arm with bucket cylinder (Included linkage and pins).

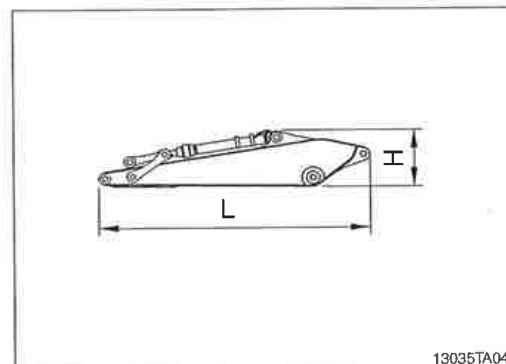



5) BUCKET ASSEMBLY

Mark	Description	Unit	Specification
L	Length	mm (ft-in)	1400 (4' 7")
H	Height	mm (ft-in)	800 (2' 7")
W	Width	mm (ft-in)	1045 (3' 5")
Wt	Weight	kg (lb)	460 (1010)

* 0.52 m³ (0.68 yd³) PCSA heaped bucket (Included tooth and side cutters).

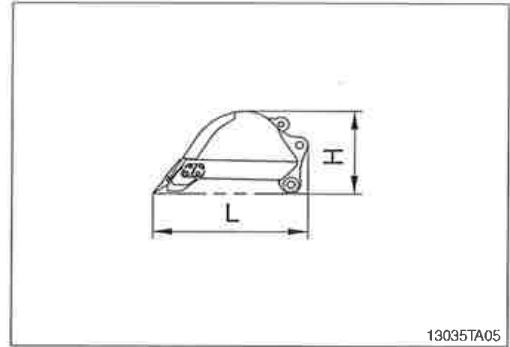

6) BOOM CYLINDER

Mark	Description	Unit	Specification
L	Length	mm (ft-in)	1760 (5' 9")
H	Height	mm (ft-in)	210 (0' 8")
W	Width	mm (ft-in)	310 (1' 0")
Wt	Weight (2 EA)	kg (lb)	260 (570)

* Included piping.

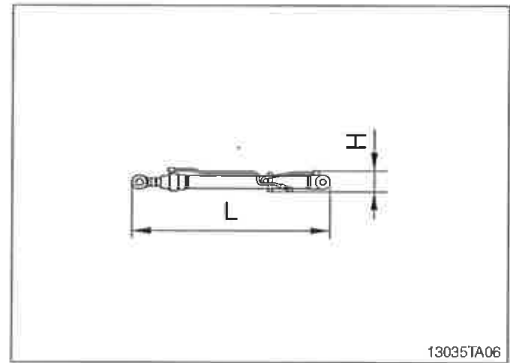

7) CAB ASSEMBLY

Mark	Description	Unit	Specification
L	Length	mm (ft-in)	2000 (6' 7")
H	Height	mm (ft-in)	1740 (5' 9")
W	Width	mm (ft-in)	1288 (4' 2")
Wt	Weight	kg (lb)	450 (990)

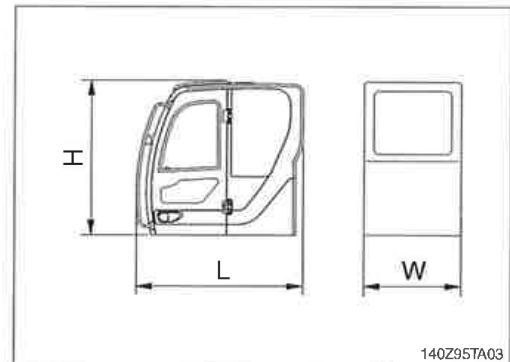

8) COUNTERWEIGHT

Mark	Description	Unit	Specification
L	Length	mm (ft-in)	2490 (8' 2")
H	Height	mm (ft-in)	1135 (3' 9")
W	Width	mm (ft-in)	960 (3' 2")
Wt	Weight	kg (lb)	2800 (6170)

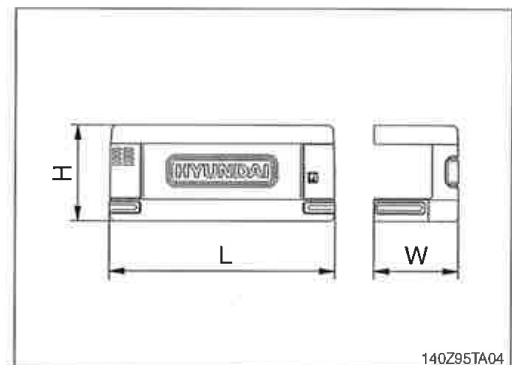

3. LOADING THE MACHINE

- 1) Load and unload the machine on a flat ground.
- 2) Use the gangplank with sufficient length, width, thickness and gradient.
- 3) Place the swing lock lever to the LOCK position before fixing the machine at the bed of trailer and confirm if the machine parallels the bed of trailer. Keep the travel motor in the rear when loading and in the front when unloading.

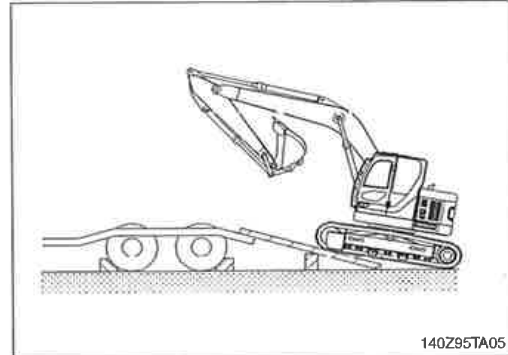

- 4) Do the following after loading the machine to the trailer.

- (1) Stop loading when the machine is located horizontally with the rear wheel of trailer.

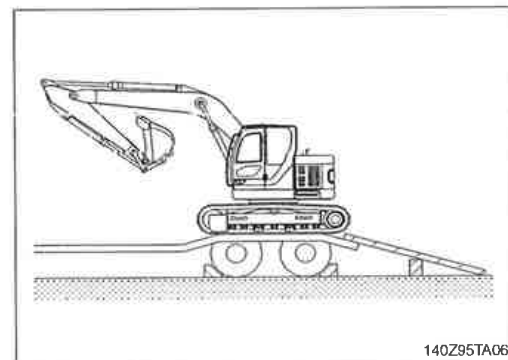

- (2) Place the swing lock lever to the LOCK position after the swing the machine 180 degree.

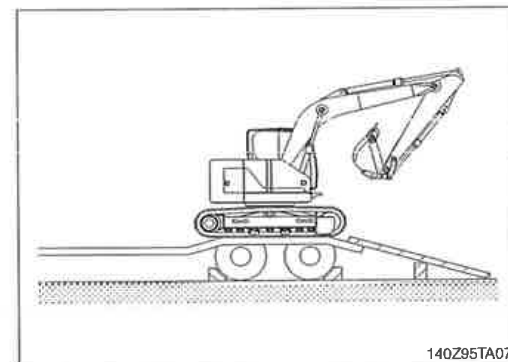



- (3) Lower the working equipment gently after the location is determined.
- ※ Place rectangular timber under the bucket cylinder to prevent the damage of it during transportation.
 - ⚠ Be sure to keep the travel speed switch on the LOW (turtle mark) while loading and unloading the machine.
 - ⚠ Avoid using the working equipment for loading and unloading since it will be very dangerous.
 - ⚠ Do not operate any other device when loading.
 - ⚠ Be careful on the boundary place of loading plate or trailer as the balance of machine will abruptly be changed on the point.

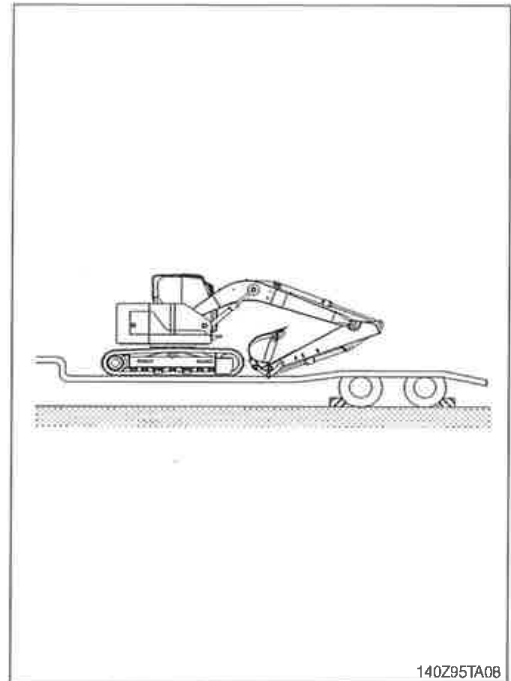

4. FIXING THE MACHINE

- 1) Lower down the working device on the loading plate of trailer.
- 2) Keep the safety lever on the LOCK position.
- 3) Turn OFF all the switches and remove the key.

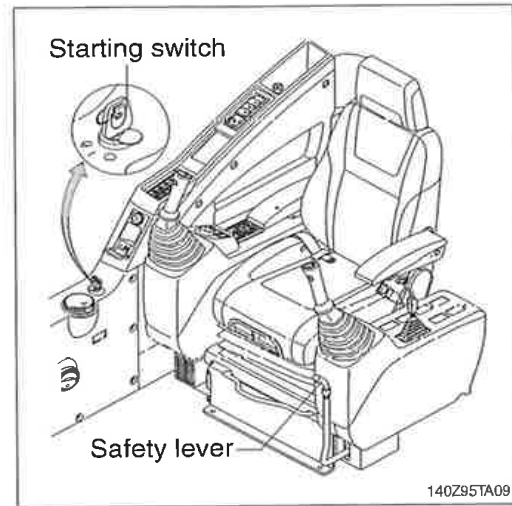

- 4) Secure all locks.

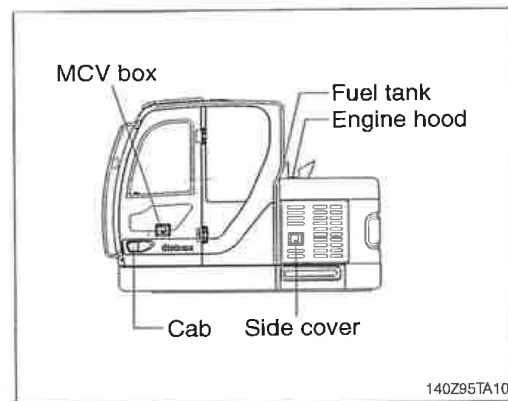

- 5) Place timber underneath of the track and fix firmly with wire rope to prevent the machine from moving forward, backward, right or left.

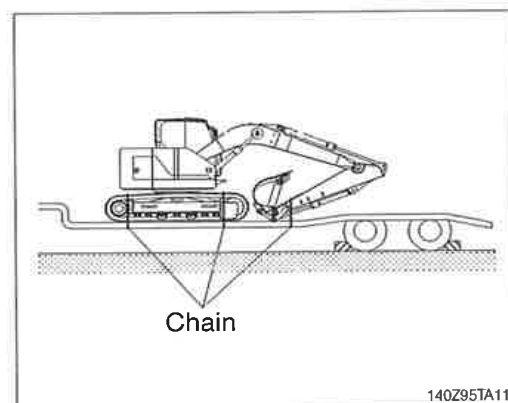



5. LOADING AND UNLOADING BY CRANE

- 1) Check the weight, length, width and height of the machine referring to the chapter 2, specification when you are going to hoist the machine.
 - 2) Use long wire rope and stay to keep the distance with the machine as it should avoid touching with the machine.
 - 3) Put a rubber plate contact with wire rope and machine to prevent damage.
 - 4) Place crane on the proper place.
 - 5) Install the wire rope and stay like the illustration.
- ▲ Make sure wire rope is proper size.
 - ▲ Place the safety lever to LOCK position to prevent the machine moving when hoisting the machine.
 - ▲ The wrong hoisting method or installation of wire rope can cause damage to the machine.
 - ▲ Do not load abruptly.
 - ▲ Keep area clear of personnel.

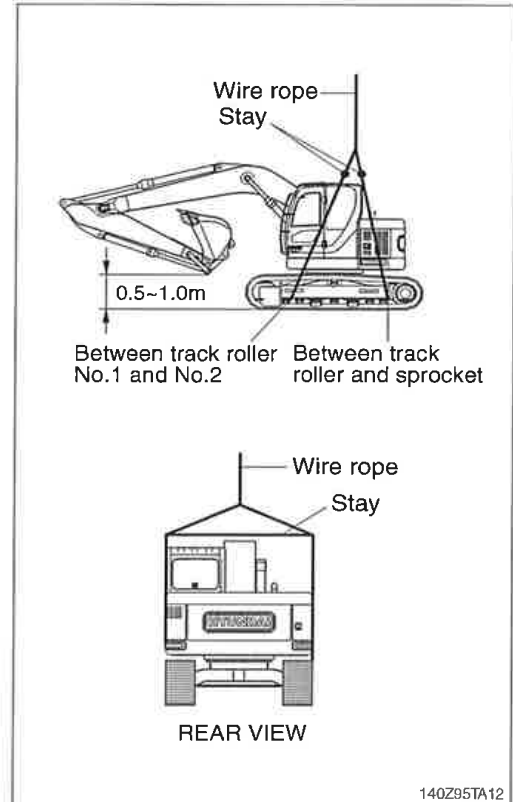



MAINTENANCE

1. INSTRUCTION

1) INTERVAL OF MAINTENANCE

- (1) You may inspect and service the machine by the period as described at page 6-11 based on hour meter at control panel.
- (2) Shorten the interval of inspect and service depending on site condition. (such as dusty area, quarry, sea shore and etc.)
- (3) Practice the entire related details at the same time when the service interval is doubled.
For example, in case of 100hours, carry out all the maintenance 「Each 100hours, each 50 hours and daily service」 at the same time.

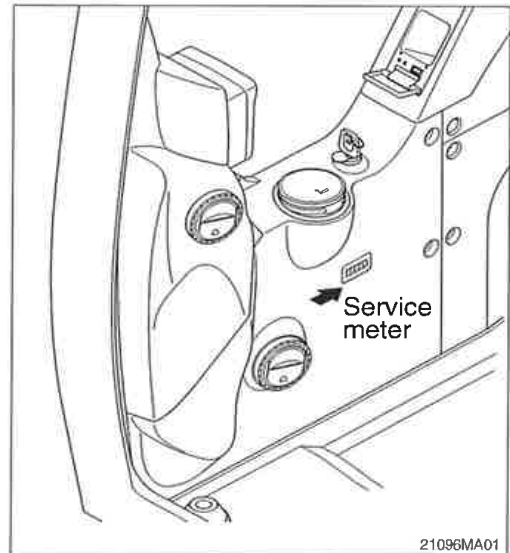

21096MA01

2) PRECAUTION

- (1) Start to maintenance after you have the full knowledge of machine.
- (2) The monitor installed on this machine does not entirely guarantee the condition of the machine. Daily inspection should be performed according to clause 4, maintenance check list.
- (3) Engine and hydraulic components have been preset in the factory.
Do not allow unauthorized personnel to reset them.
- (4) Ask to your local dealer or Hyundai for the maintenance advice if unknown.
- (5) Drain the used oil and coolant in a container and handle according to the method of handling for industrial waste to meet with regulations of each province or country.



3) PROPER MAINTENANCE

(1) Replace and repair of parts

It is required to replace the wearable and consumable parts such as bucket tooth, side cutter, filter and etc., regularly.

Replace damaged or worn parts at proper time to keep the performance of machine.

- (2) Use genuine parts.
- (3) Use the recommended oil.
- (4) Remove the dust or water around the inlet of oil tank before supplying oil.
- (5) Drain oil when the temperature of oil is warm.
- (6) Do not repair anything while operating the engine.
Stop the engine when you fill the oil.
- (7) Relieve hydraulic system of the pressure before repairing the hydraulic system.
- (8) Confirm if the cluster is in the normal condition after completion of service.
- (9) For more detail information of maintenance, please contact local Hyundai dealer.
※ **Be sure to start the maintenance after fully understand the chapter 1, safety hints.**



4) RELIEVING THE PRESSURE IN THE HYDRAULIC SYSTEM

※ Spouting of oil can cause the accident when loosening the cap or hose right after the operating of machine as the machine or oil is on the high pressure on the condition.

Be sure to relieve the pressure in the system before repairing hydraulic system.

- (1) Place machine in parking position, and stop the engine.

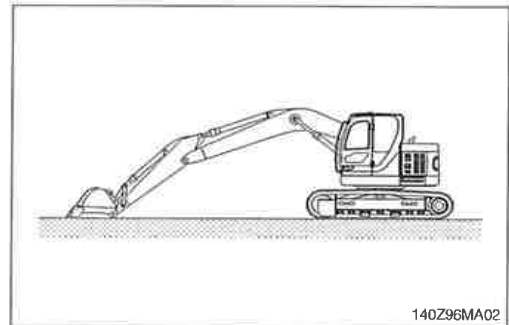

- (2) Set the safety lever completely in the release position, operate the control levers and pedals fully to the front, rear, left and right, to release the pressure in the hydraulic circuit.

※ This does not completely release the pressure, so when serving hydraulic component, loosen the connections slowly and do not stand in the direction where the oil spurts out.

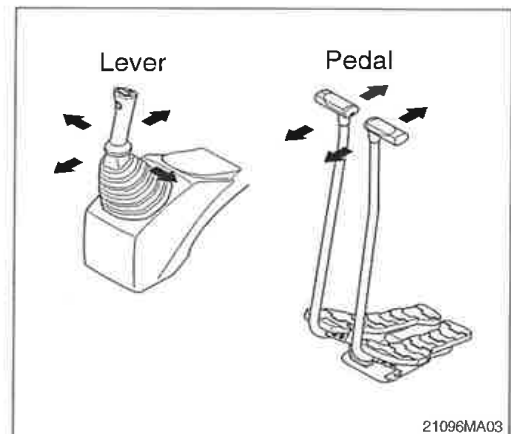

- (3) Loosen the cap and relieve the pressure in the tank by pushing the top of the air breather.

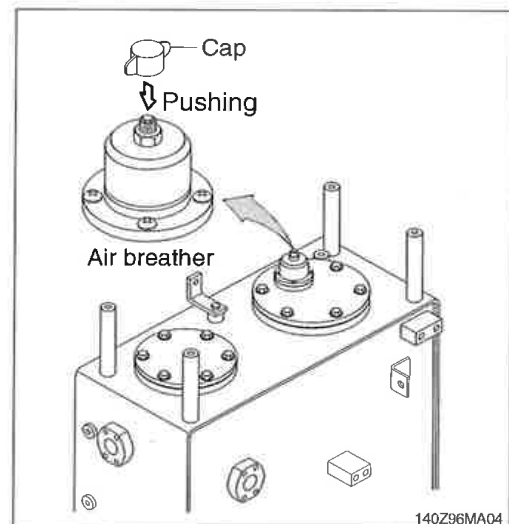



5) PRECAUTION WHEN INSTALLING HYDRAULIC HOSES OR PIPES

- (1) Be particularly careful that the joint of hose, pipe and functioning item are not damaged.
Avoid contamination.
- (2) Assemble after cleaning the hose, pipe and joint of functioning item.
- (3) Use genuine parts.
- (4) Do not assemble the hose in the condition of twisted or sharp radius.
- (5) Keep the specified tighten torque.



6) PERIODICAL REPLACEMENT OF SAFETY PARTS

- (1) It is desirable to do periodic maintenance the machine for using the machine safely for a long time.
However, recommend to replace regularly the parts related safety not only safety but maintain satisfied performance.
- (2) These parts can cause the disaster of life and material as the quality changes by passing time and it is worn, diluted, and gets fatigued by using repeatedly.
These are the parts which the operator can not judge the remained lifetime of them by visual inspection.
- (3) Repair or replace if an abnormality of these parts is found even before the recommended replacement interval.

Periodical replacement of safety parts		Interval	
Engine	Fuel hose (tank-engine)	Every 2 years	
	Heater hose (heater-engine)		
Hydraulic system	Main circuit	Pump suction hose	Every 2 years
		Pump delivery hose	
		Swing hose	
	Working device	Boom cylinder line hose	Every 2 years
		Arm cylinder line hose	
		Bucket cylinder line hose	

- ※ 1. Replace O-ring and gasket at the same time when replacing the hose.
- 2. Replace clamp at the same time if the hose clamp is cracked when checking and replacing the hose.



2. TIGHTENING TORQUE

Use following table for unspecified torque.

1) BOLT AND NUT

(1) Coarse thread

Bolt size	8T		10T	
	kg · m	lb · ft	kg · m	lb · ft
M 6 × 1.0	0.85 ~ 1.25	6.15 ~ 9.04	1.14 ~ 1.74	8.2 ~ 12.6
M 8 × 1.25	2.0 ~ 3.0	14.5 ~ 21.7	2.7 ~ 4.1	19.5 ~ 29.7
M10 × 1.5	4.0 ~ 6.0	28.9 ~ 43.4	5.5 ~ 8.3	39.8 ~ 60
M12 × 1.75	7.4 ~ 11.2	53.5 ~ 81.0	9.8 ~ 15.8	70.9 ~ 114
M14 × 2.0	12.2 ~ 16.6	88.2 ~ 120	16.7 ~ 22.5	121 ~ 163
M16 × 2.0	18.6 ~ 25.2	135 ~ 182	25.2 ~ 34.2	182 ~ 247
M18 × 2.5	25.8 ~ 35.0	187 ~ 253	35.1 ~ 47.5	254 ~ 344
M20 × 2.5	36.2 ~ 49.0	262 ~ 354	49.2 ~ 66.6	356 ~ 482
M22 × 2.5	48.3 ~ 63.3	349 ~ 458	65.8 ~ 98.0	476 ~ 709
M24 × 3.0	62.5 ~ 84.5	452 ~ 611	85.0 ~ 115	615 ~ 832
M30 × 3.0	124 ~ 168	898 ~ 1214	169 ~ 229	1223 ~ 1656
M36 × 4.0	174 ~ 236	1261 ~ 1704	250 ~ 310	1808 ~ 2242

(2) Fine thread

Bolt size	8T		10T	
	kg · m	lb · ft	kg · m	lb · ft
M 8 × 1.0	2.2 ~ 3.4	15.9 ~ 24.6	3.0 ~ 4.4	21.7 ~ 31.8
M10 × 1.2	4.5 ~ 6.7	32.5 ~ 48.5	5.9 ~ 8.9	42.7 ~ 64.4
M12 × 1.25	7.8 ~ 11.6	56.4 ~ 83.9	10.6 ~ 16.0	76.7 ~ 116
M14 × 1.5	13.3 ~ 18.1	96.2 ~ 131	17.9 ~ 24.1	130 ~ 174
M16 × 1.5	19.9 ~ 26.9	144 ~ 195	26.6 ~ 36.0	192 ~ 260
M18 × 1.5	28.6 ~ 43.6	207 ~ 315	38.4 ~ 52.0	278 ~ 376
M20 × 1.5	40.0 ~ 54.0	289 ~ 391	53.4 ~ 72.2	386 ~ 522
M22 × 1.5	52.7 ~ 71.3	381 ~ 516	70.7 ~ 95.7	511 ~ 692
M24 × 2.0	67.9 ~ 91.9	491 ~ 665	90.9 ~ 123	658 ~ 890
M30 × 2.0	137 ~ 185	990 ~ 1339	182 ~ 248	1314 ~ 1796
M36 × 3.0	192 ~ 260	1390 ~ 1880	262 ~ 354	1894 ~ 2562



2) PIPE AND HOSE (FLARE type)

Thread size (PF)	Width across flat (mm)	kgf · m	lbf · ft
1/4"	19	4	28.9
3/8"	22	5	36.2
1/2"	27	9.5	68.7
3/4"	36	18	130
1"	41	21	152
1-1/4"	50	35	253

3) PIPE AND HOSE (ORFS type)

Thread size (UNF)	Width across flat (mm)	kgf · m	lbf · ft
9/16-18	19	4	28.9
11/16-16	22	5	36.2
13/16-16	27	9.5	68.7
1-3/16-12	36	18	130
1-7/16-12	41	21	152
1-11/16-12	50	35	253

4) FITTING

Thread size	Width across flat (mm)	kgf · m	lbf · ft
1/4"	19	4	28.9
3/8"	22	5	36.2
1/2"	27	9.5	68.7
3/4"	36	18	130
1"	41	21	152
1-1/4"	50	35	253



4) TIGHTENING TORQUE OF MAJOR COMPONENT

No.	Descriptions	Bolt size	Torque		
			kgf · m	lbf · ft	
1	Engine	Engine mounting bolt (engine-bracket)	M12 × 1.75	10 ± 1.0	72.3 ± 7.2
2		Engine mounting bolt (bracket-frame, FR)	M16 × 2.0	30 ± 3.5	217 ± 25.3
3		Engine mounting bolt (bracket-frame, RR)	M20 × 2.5	55 ± 3.5	398 ± 25.3
4		Radiator mounting bolt	M16 × 2.0	29.7 ± 4.5	215 ± 32.5
5		Coupling mounting socket bolt	M16 × 2.0	22 ± 1.0	159 ± 7.2
6		Main pump housing mounting bolt	M10 × 1.5	6.0 ± 0.3	43.4 ± 2.2
7	Hydraulic system	Main pump mounting socket bolt	M16 × 2.0	22 ± 1.0	159 ± 7.2
8		Main control valve mounting bolt	M12 × 1.75	12.2 ± 1.3	88.2 ± 9.4
9		Fuel tank mounting bolt	M20 × 2.5	46 ± 5.1	333 ± 36.9
10		Hydraulic oil tank mounting bolt	M20 × 2.5	46 ± 5.1	333 ± 36.9
11		Turning joint mounting bolt, nut	M12 × 1.75	12.3 ± 1.3	88.9 ± 9.4
12	Power train system	Swing motor mounting bolt	M16 × 2.0	29.6 ± 3.2	214 ± 23.1
13		Swing bearing upper part mounting bolt	M18 × 2.5	41.3 ± 4.5	299 ± 32.5
14		Swing bearing lower part mounting bolt	M16 × 1.5	31.3 ± 3.2	226 ± 23.1
15		Travel motor mounting bolt	M16 × 2.0	25.7 ± 4.0	186 ± 28.9
16		Sprocket mounting bolt	M16 × 2.0	23 ± 2.5	166 ± 18.1
17	Under carriage	Carrier roller mounting bolt, nut	M16 × 2.0	29.7 ± 4.4	215 ± 31.8
18		Track roller mounting bolt	M16 × 2.0	29.6 ± 3.2	214 ± 23.1
19		Track tension cylinder mounting bolt	M16 × 2.0	21.9 ± 3.3	158 ± 23.9
20		Track shoe mounting bolt, nut	5/8 - 18UNF	42 ± 4.0	304 ± 28.9
21		Track guard mounting bolt	M16 × 2.0	29.6 ± 3.2	214 ± 23.1
22	Others	Counterweight mounting bolt	M36 × 3.0	308 ± 46	2228 ± 333
23		Cab mounting bolt	M12 × 1.75	12.8 ± 3.0	92.6 ± 21.7
24		Operator's seat mounting bolt	M 8 × 1.25	4.05 ± 0.8	29.3 ± 5.8

※ For tightening torque of engine and hydraulic components, see engine maintenance guide and service manual.



3. FUEL, COOLANT AND LUBRICANTS

1) NEW MACHINE

New machine used and filled with following lubricants.

Description	Specification
Engine oil	SAE 15W-40 (API CH-4)
Hydraulic oil	Hyundai genuine long life hydraulic oil (ISO VG46, VG68 only) Conventional hydraulic oil (ISO VG32)
Swing and travel reduction gear	SAE 85W-140 (API GL-5)
Grease	Lithium base grease NLGI No. 2
Fuel	ASTM D975-No. 2
Coolant	Mixture of 50% ethylene glycol base antifreeze and 50% water.

- SAE** : Society of Automotive Engineers
API : American Petroleum Institute
ISO : International Organization for Standardization
NLGI : National Lubricating Grease Institute
ASTM : American Society of Testing and Material



2) RECOMMENDED OILS

Use only oils listed below or equivalent.
Do not mix different brand oil.

Service point	Kind of fluid	Capacity l (U.S. gal)	Ambient temperature °C (°F)								
			-20 (-4)	-10 (14)	0 (32)	10 (50)	20 (68)	30 (86)	40 (104)		
Engine oil pan	Engine oil	17.5 (4.6)					SAE 30				
			SAE 10W								
			SAE 10W-30								
			SAE 15W-40								
Swing drive	Grease	0.35 (0.09)	NLGI NO.1								
							NLGI NO.2				
Swing drive	Gear oil	2.5 (0.7)	SAE 85W-140								
Final drive		1.8 × 2 (0.48 × 2)									
Hydraulic tank	Hydraulic oil	Tank: 96 (25.4) System: 180 (47.6)	ISO VG 32								
									ISO VG 46		
								ISO VG 68			
Fuel tank	Diesel fuel	232 (61.3)	ASTM D975 NO.1								
							ASTM D975 NO.2				
Fitting (Grease nipple)	Grease	As required	NLGI NO.1								
								NLGI NO.2			
Radiator (Reservoir tank)	Mixture of antifreeze and water 50 : 50	15.5 (4.1)	Ethylene glycol base permanent type								

- SAE : Society of Automotive Engineers
- API : American Petroleum Institute
- ISO : International Organization for Standardization
- NLGI : National Lubricating Grease Institute
- ASTM : American Society of Testing and Material



4. MAINTENANCE CHECK LIST

1) DAILY SERVICE BEFORE STARTING

Check items	Service	Page
Visual check		
Fuel tank	Check, Refill	6-25
Hydraulic oil level	Check, Add	6-29
Engine oil level	Check, Add	6-18
Coolant level	Check, Add	6-20
Control panel & pilot lamp	Check, Clean	6-39
Prefilter	Check, Clean	6-26
Fan belt tension	Check, Adjust	6-24
★ Attachment pin and bushing	Lubricate	6-38
· Boom cylinder tube end		
· Boom foot		
· Boom cylinder rod end		
· Arm cylinder tube end		
· Arm cylinder rod end		
· Boom + Arm connecting		
· Bucket cylinder tube end		

★ Lubricate every 10 hours or daily for initial 100 hours.

2) EVERY 50 HOURS SERVICE

Check items	Service	Page
Fuel tank (water, sediment)	Drain	6-25
Track tension	Check, Adjust	6-34
Swing bearing grease	Lubricate	6-32
Swing reduction gear oil	Check, Add	6-32
Attachment pin and bushing	Lubricate	6-38
· Bucket cylinder rod end		
· Bucket + Arm connecting		
· Bucket control link + Arm		
· Bucket control rod		



3) INITIAL 50 HOURS SERVICE

Check items	Service	Page
Engine oil	Change	6-18, 19
Engine oil filter	Replace	6-18, 19
Prefilter (water, element)	Replace	6-26
Fuel filter	Replace	6-27
Bolts & Nuts	Check, Tight	6-8
<ul style="list-style-type: none"> · Sprocket mounting bolts · Travel motor mounting bolts · Swing motor mounting bolts · Swing bearing mounting bolts · Engine mounting bolts · Counterweight mounting bolts · Turning joint locating bolts · Track shoe mounting bolts and nuts · Hydraulic pump mounting bolts 		

※ Service the above items only for the new machine, and thereafter keep the normal service interval.

4) EVERY 200 HOURS SERVICE

Check items	Service	Page
★ Return filter	Replace	6-30
★ Pilot line filter	Replace	6-31
★ Drain filter cartridge	Replace	6-31

★ Replace 3 filters for continuous hydraulic breaker operation only.

5) INITIAL 250 HOURS SERVICE

Check items	Service	Page
Pilot line filter	Replace	6-31
Hydraulic return filter	Replace	6-30
Drain filter cartridge	Replace	6-31
Swing reduction gear oil	Change	6-32



6) EVERY 250 HOURS SERVICE

Check items	Service	Page
Battery (voltage)	Check, Clean	6-39
Aircon & heater fresh air filter	Check	6-43
Air breather element	Replace	6-31
Bolts & Nuts	Check, Tight	6-8
<ul style="list-style-type: none"> • Sprocket mounting bolts • Travel motor mounting bolts • Swing motor mounting bolts • Swing bearing mounting bolts • Engine mounting bolts • Counterweight mounting bolts • Turning joint locating bolts • Track shoe mounting bolts and nuts • Hydraulic pump mounting bolts 		
Attachment pin and bushing	Lubricate	6-38
<ul style="list-style-type: none"> • Boom cylinder tube end • Boom foot • Boom cylinder rod end • Arm cylinder tube end • Arm cylinder rod end • Boom + Arm connecting • Bucket cylinder tube end 		

7) INITIAL 500 HOURS SERVICE

Check items	Service	Page
Travel reduction gear oil	Change	6-33

※ Service the above item only for the new machine, and thereafter keep the normal service interval.



8) EVERY 500 HOURS SERVICE

Check items	Service	Page
★ Engine oil	Change	6-18, 19
★ Engine oil filter	Replace	6-18, 19
Radiator, cooler fin and charge air cooler	Check, Clean	6-23
☆ Air cleaner element (primary)	Check, Clean	6-25
Fuel filter element	Replace	6-27
Prefilter	Replace	6-26

★ If you use high sulfur containing fuel above than 0.5% or use low grade of engine oil reduce change interval.

☆ Clean the primary element only after 500 hours operation or when the air cleaner warning lamp blinks. Replace primary element and safety element after 4 times cleanings of primary element.

9) EVERY 1000 HOURS SERVICE

Check items	Service	Page
Travel motor reduction gear oil	Change	6-33
Swing reduction gear oil	Change	6-32
Grease in swing gear and pinion	Change	6-32
Hydraulic oil return filter	Replace	6-30
Drain filter cartridge	Replace	6-31
Pilot line filter	Replace	6-31

10) EVERY 2000 HOURS SERVICE

Check items	Service	Page
Hydraulic tank		
★ Oil *1	Change	6-30
· Suction strainer	Check, Clean	6-30
Coolant	Change	6-20, 21, 22, 23

*1 Conventional hydraulic oil

★ Change oil every 600 hours of continuous hydraulic breaker operation.

11) EVERY 5000 HOURS SERVICE

Check items	Service	Page
Hydraulic tank		
★ Oil *2	Change	6-30

*2 Hyundai genuine long life hydraulic oil

★ Change oil every 1000 hours of continuous hydraulic breaker operation.



12) WHEN REQUIRED

Whenever you have trouble in the machine, you must perform the service of related items, system by system.

Check items	Service	Page
Fuel system		
· Fuel tank	Drain or Clean	6-25
· Prefilter	Clean or Replace	6-26
· Fuel filter element	Replace	6-27
Engine lubrication system		
· Engine oil	Change	6-18, 19
· Engine oil filter	Replace	6-18, 19
Engine cooling system		
· Coolant	Add or Change	6-20, 21, 22, 23
· Radiator	Clean or Flush	6-20, 21, 22, 23
· Charge air cooler	Check	6-23
Engine air system		
· Air cleaner element	Replace	6-25
Hydraulic system		
· Hydraulic oil	Add or Change	6-29
· Return filter	Replace	6-30
· Drain line filter	Replace	6-31
· Pilot line filter	Replace	6-31
· Element of breather	Replace	6-31
· Suction strainer	Clean	6-30
Under carriage		
· Track tension	Check, Adjust	6-34
Bucket		
· Tooth	Replace	6-36
· Side cutter	Replace	6-36
· Linkage	Adjust	6-37
· Bucket assy	Replace	6-35
Air conditioner and heater		
· Fresh air filter	Clean, Replace	6-42
· Recirculation filter	Clean	6-43

5. MAINTENANCE CHART

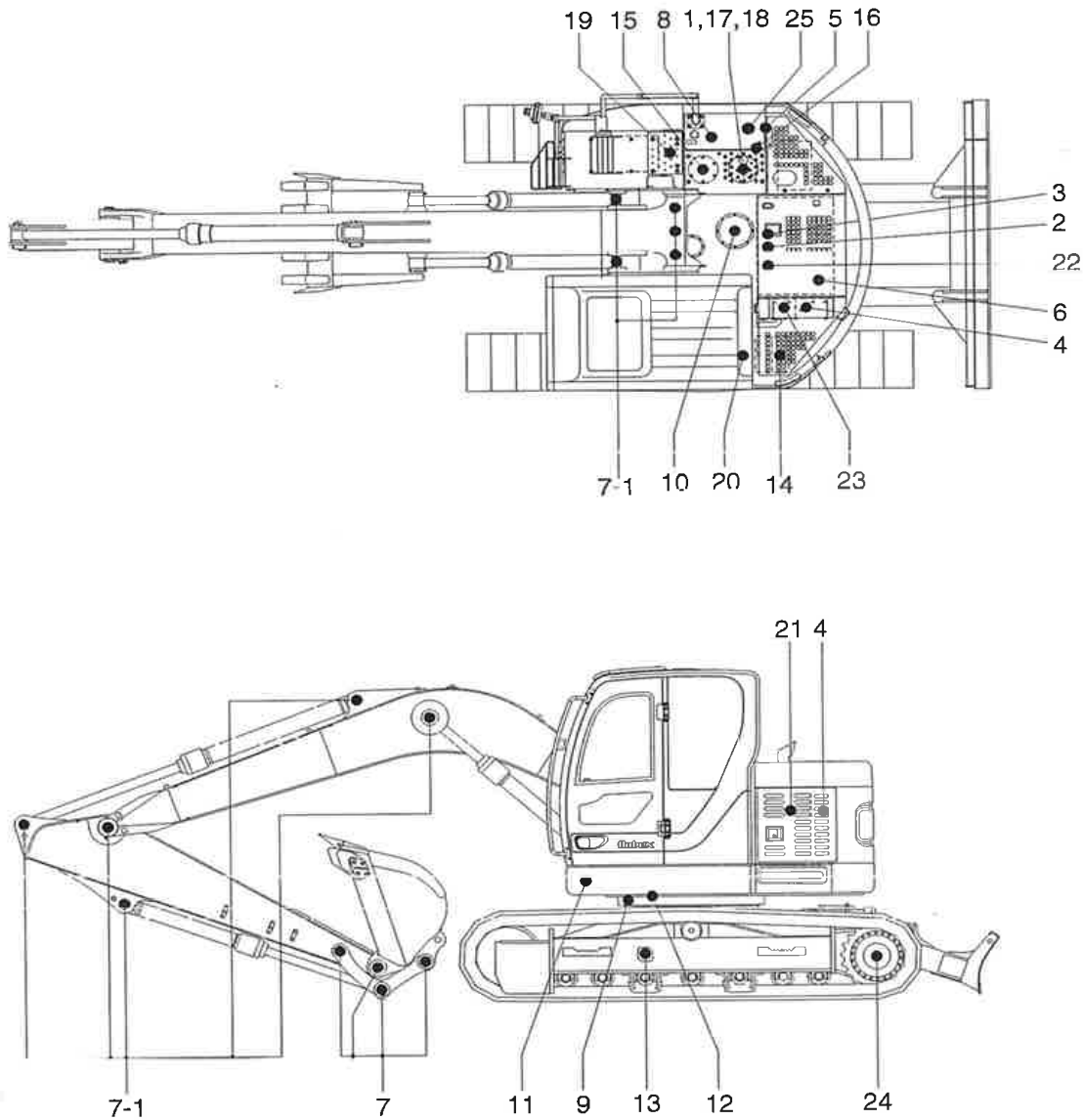

Caution

1. Service intervals are based on the hour meter reading.
2. The number of each item shows the lubrication point on the machine.
3. Stop engine while filling oil, and use no open flames.

140Z96MA05



Service interval	No.	Description	Service action	Oil symbol	Capacity l (U.S.gal)	Service points No.
10 Hours or daily	1	Hydraulic oil level	Check, Add	HO	96 (25.4)	1
	2	Engine oil level	Check, Add	EO	17.5 (4.6)	1
	4	Radiator coolant	Check, Add	C	15.5 (4.1)	1
	5	Prefilter (water, element)	Check, Clean	-	-	1
	6	Fan belt tension and damage	Check, Adjust	-	-	1
	25	Fuel tank	Check, Refill	DF	232 (61.3)	1
50 Hours or weekly	7	Attachment pins & bushing	Check, Add	PGL	-	5
	8	Fuel tank (water, sediment)	Check, Clean	-	-	1
	9	Swing bearing grease	Check, Add	PGL	-	3
	10	Swing reduction gear case	Check, Add	GO	2.5 (0.66)	1
	13	Track tension	Check, Adjust	PGL	-	2
250 Hours	7-1	Attachment pins & bushing	Check, Add	PGL	-	12
	14	Battery (voltage)	Check, Clean	-	-	1
	17	Air breather element	Replace	-	-	1
	20	Aircon and heater fresh air filter	Check, Clean	-	-	1
500 Hours	2	Engine oil	Change	EO	17.5 (4.6)	1
	3	Engine oil filter	Replace	-	-	1
	5	Prefilter	Replace	-	-	1
	21	Air cleaner element (primary)	Check, Clean	-	-	1
	22	Fuel filter element	Replace	-	-	1
	23	Radiator, oil cooler, charge air cooler	Check, Clean	-	-	3
1000 Hours	10	Swing reduction gear case	Change	GO	2.5 (0.66)	1
	12	Swing gear and pinion grease	Change	PGL	7.4 kg (16.3 lb)	1
	15	Hydraulic oil return filter	Replace	-	-	1
	16	Drain filter cartridge	Replace	-	-	1
	19	Pilot line filter element	Replace	-	-	1
	24	Travel reduction gear case	Change	GO	1.8 (0.48)	2
2000 Hours	1	Hydraulic oil * ¹	Change	HO	96 (25.4)	1
	4	Radiator coolant	Change	C	15.5 (4.1)	1
	18	Hydraulic oil suction strainer	Check, Clean	-	-	1
5000 Hours	1	Hydraulic oil * ²	Change	HO	96 (25.4)	1
As required	20	Aircon & heater fresh filter	Replace	-	-	1
	20	Aircon & heater recirculation filter	Clean, Replace	-	-	1
	21	Air cleaner element (primary, safety)	Replace	-	-	2

*¹ Conventional hydraulic oil *² Hyundai genuine long life hydraulic oil

※ Oil symbol

Please refer to the recommended lubricants for specification.

DF : Diesel fuel GO : Gear oil HO : Hydraulic oil
C : Coolant PGL : Grease EO : Engine oil

6. SERVICE INSTRUCTION

1) CHECK ENGINE OIL LEVEL

Check the oil level with the machine on a flat ground before starting engine.

- (1) Pull out the dipstick and wipe with a clean cloth.
 - (2) Check the oil level by inserting the dipstick completely into the hole and pulling out again.
 - (3) If oil level is LOW, add oil and then check again.
 - ※ If the oil is contaminated or diluted, change the oil regardless of the regular change interval.
 - ※ Check oil level after engine has been stopped for 15 minutes.
- ▲ Do not operate unless the oil level is in the normal range.

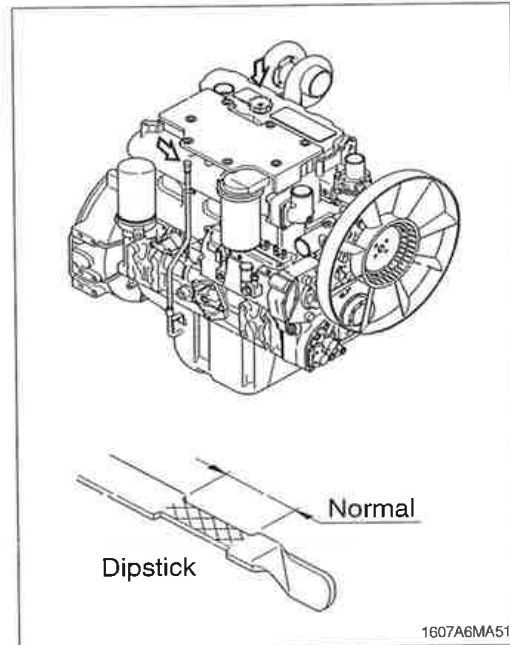

2) REPLACEMENT OF ENGINE OIL AND OIL FILTER

- (1) Warm up the engine.
- (2) Open the drain cock and allow the oil to drain.
 - ※ A drain pan with a capacity of 20 liters (5 U.S. gallons) will be adequate.

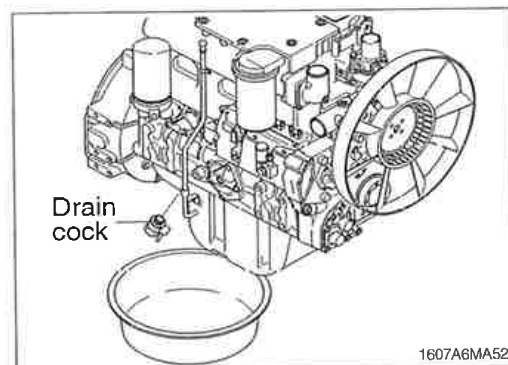

- (3) Clean around the filter head, remove the filter with a filter wrench and clean the gasket surface.
 - ※ The O-ring can stick on the filter head. Make sure it is removed before installing the new filter.

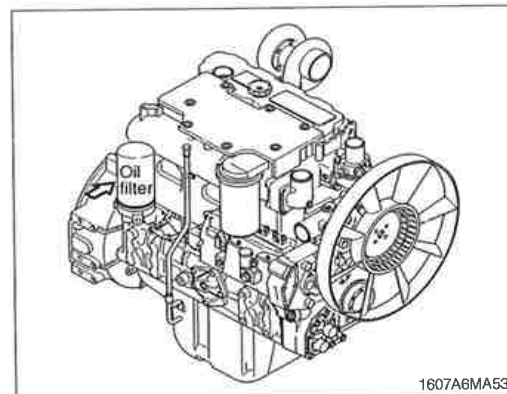



- (4) Apply a light film of lubricating oil to the gasket sealing surface before installing the filters.



- (5) Install the filter to the filter head.
 ※ **Mechanical over-tightening may distort the threads or damage the filter element seal.**
 • Install the filter as specified by the filter manufacturer.

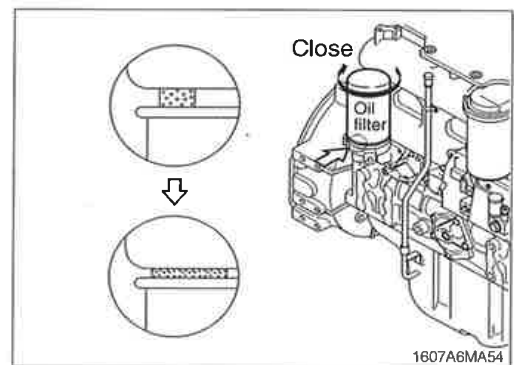

- (6) Fill the engine with clean oil to the proper level.
 • Quantity : 17.5 l (4.6 U.S.gallons)

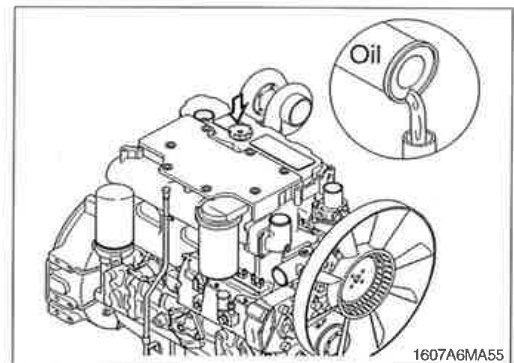

- (7) Operate the engine at low idle and inspect for leaks at the filters and the drain plug.
 Shut the engine off and check the oil level with the dipstick. Allow 15minutes for oil to drain down before checking.

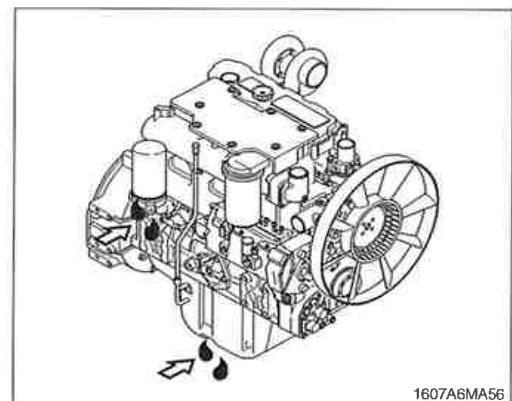

3) CHECK COOLANT

- (1) Check if the level of coolant in reservoir tank is between FULL and LOW.
 - (2) Add the mixture of antifreeze and water after removing the cap of the reservoir tank if coolant is not sufficient.
 - (3) Be sure to add the coolant by opening the cap of radiator when coolant level is below LOW.
 - (4) Replace gasket of radiator cap when it is damaged.
- ▲ Hot coolant can spray out if radiator cap is removed while engine is hot. Remove the cap after the engine has cooled down.**

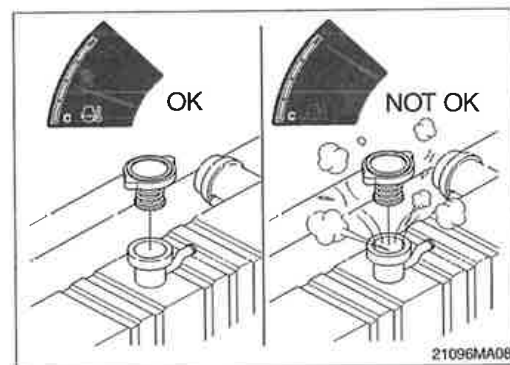
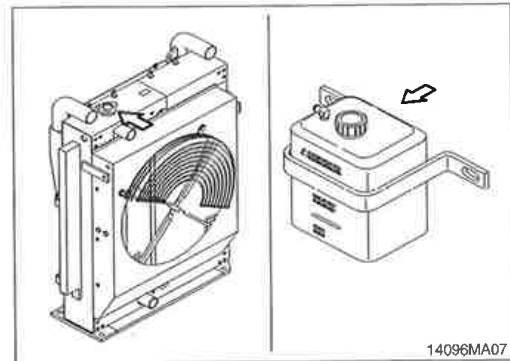

4) FLUSHING AND REFILLING OF RADIATOR

(1) Change coolant

- ▲ Avoid prolonged and repeated skin contact with used antifreeze. Such prolonged repeated contact can cause skin disorders or other bodily injury.**

Avoid excessive contact-wash thoroughly after contact.

Keep out of reach of children.

- ※ **Protect the environment :** Handling and disposal of used antifreeze can be subject to federal, state, and local law regulation. Use authorized waste disposal facilities, including civic amenity sites and garages providing authorized facilities for the receipt of used antifreeze.

If in doubt, contact your local authorities for guidance as to proper handling of used antifreeze.

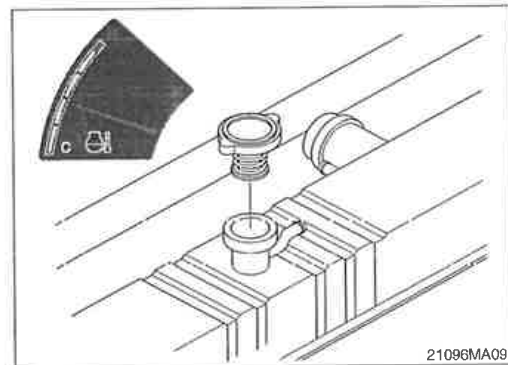



▲ Wait until the temperature is below 50°C (122°F) before removing the coolant system pressure cap.

Failure to do so can cause personal injury from heated coolant spray.

Drain the cooling system by opening the drain cock on the radiator and removing the hose in the bottom of the water inlet. A drain pan with a capacity of 40 liters (10 U.S.gallons) will be adequate in most applications.

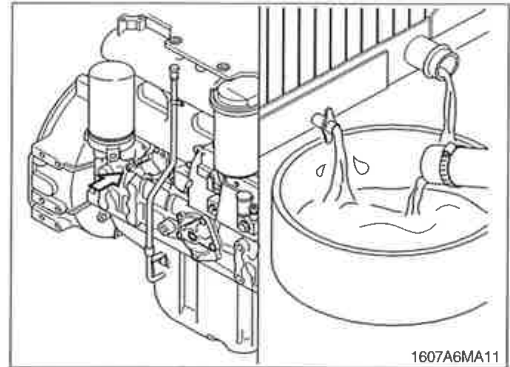

(2) Flushing of cooling system

① Fill the system with a mixture of sodium carbonate and water (or a commercially available equivalent).

※ Use 0.5 kg (1.0 pound) of sodium carbonate for every 23 liters (6.0 U.S. gallons) of water.

※ Do not install the radiator cap. The engine is to be operated without the cap for this process.

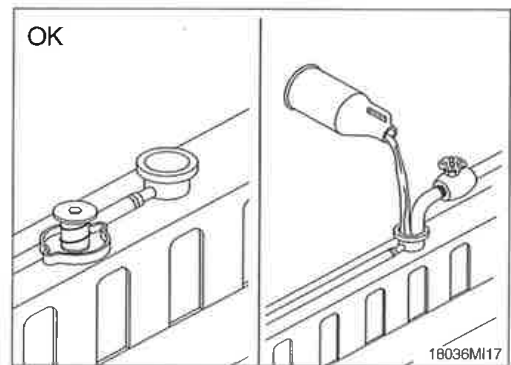

② Operate the engine for 5 minutes with the coolant temperature above 80°C (176°F).

Shut the engine off, and drain the cooling system.

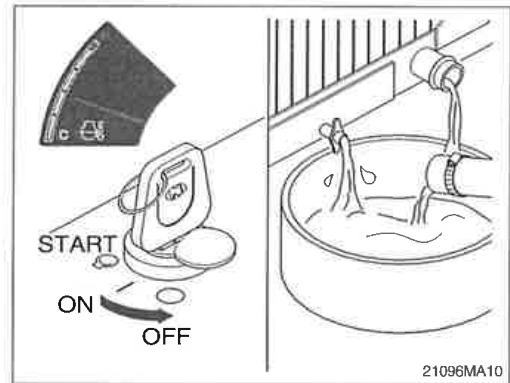

③ Fill the cooling system with clean water.

※ Be sure to vent the engine and aftercooler for complete filling.

※ Do not install the radiator cap or the new coolant filter.

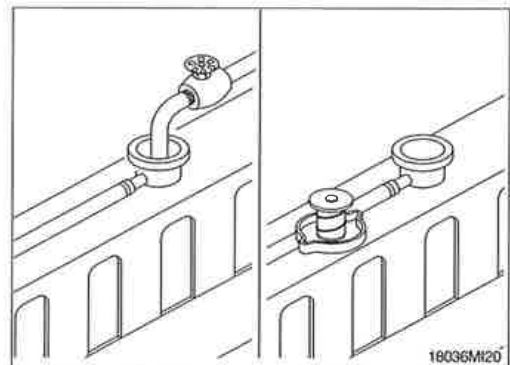



- ④ Operate the engine for 5 minutes with the coolant temperature above 80°C (176°F).
Shut the engine off, and drain the cooling system.
- ※ If the water being drained is still dirty, the system must be flushed again until the water is clean.

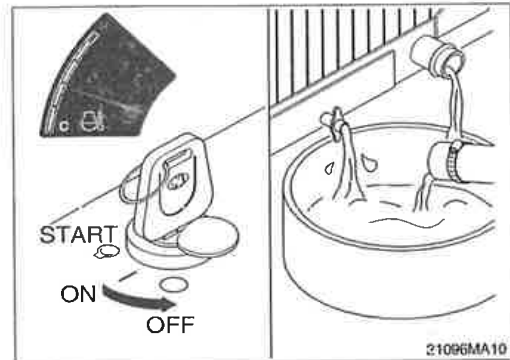

(3) Cooling system filling

- ① Use a mixture of 50 percent water and 50 percent ethylene glycol antifreeze to fill the cooling system.
Coolant capacity (engine only) : 6 l (1.6 U.S. gallons)
- ※ Use the correct amount of DCA4 corrosion inhibitor to protect the cooling system.

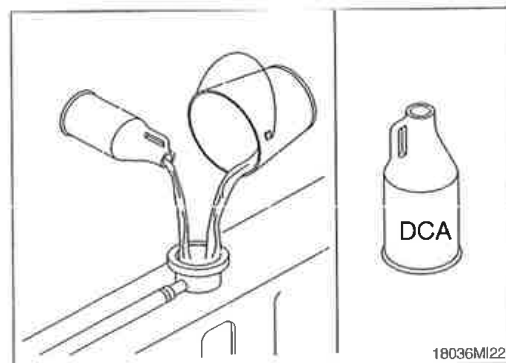

- ② The system has a maximum fill rate of 14 liters (3.5 U.S. gallons) per minute.
Do not exceed this fill rate.
- ※ The system must be filled slowly to prevent air locks.
During filling, air must be vented from the engine coolant passage.

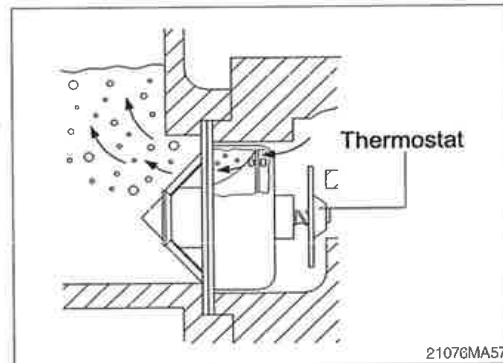

- ③ Install the pressure cap. Operate the engine until it reaches a temperature 80°C (176°F), and check for coolant leaks.
Check the coolant level again to make sure the system is full of coolant.

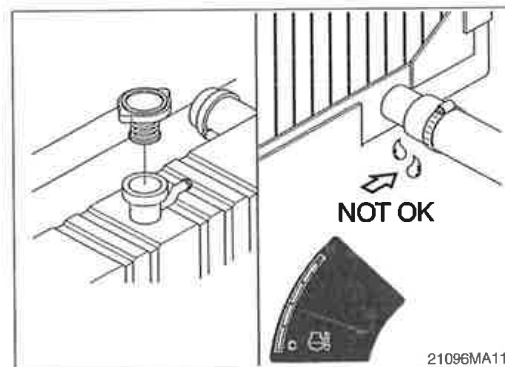

5) CLEAN RADIATOR AND OIL COOLER

Check, and if necessary, clean and dry outside of radiator and oil cooler. After working in a dusty place, clean radiator more frequently.

- (1) Visually inspect the radiator for clogged radiator fins.
- (2) Use 550 kPa (80 psi) air pressure to blow the dirt and debris from the fins.
Blow the air in the opposite direction of the fan air flow.
- (3) Visually inspect the radiator for bent or broken fins.
- ※ If the radiator must be replaced due to bent or broken fins which can cause the engine to overheat, refer to the manufacturer's replacement procedures.
- (4) Visually inspect the radiator for core and gasket leaks.

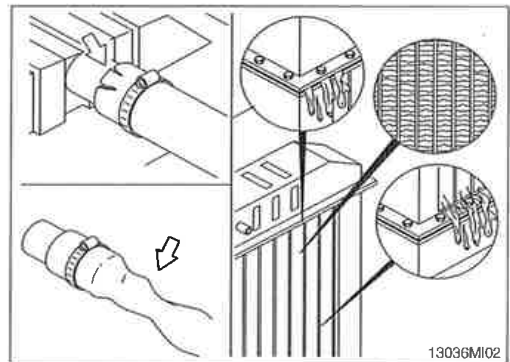
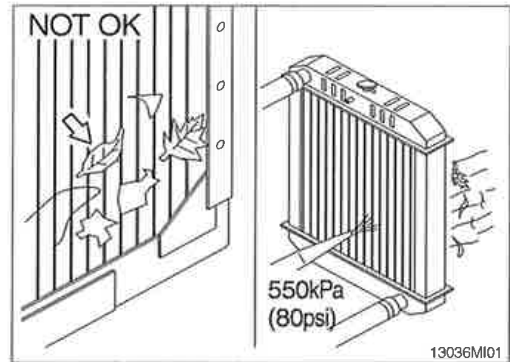

6) CHECK CHARGE AIR COOLER

Inspect the charge air cooler for dirt and debris blocking the fins. Check for cracks, holes, or other damage. If damage is found, please contact Hyundai distributor.

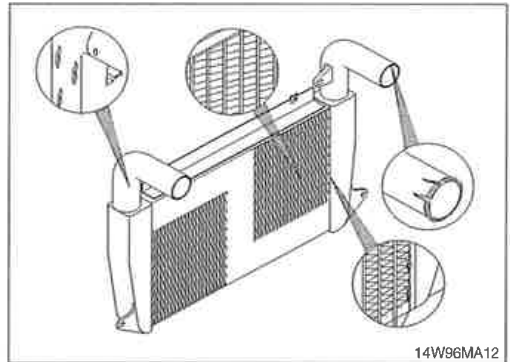

7) FAN BELT TENSION

- (1) Measure the belt deflection at the longest span of the belt.
 - Maximum deflection : 7 ± 1 mm (0.28 ± 0.04 in)

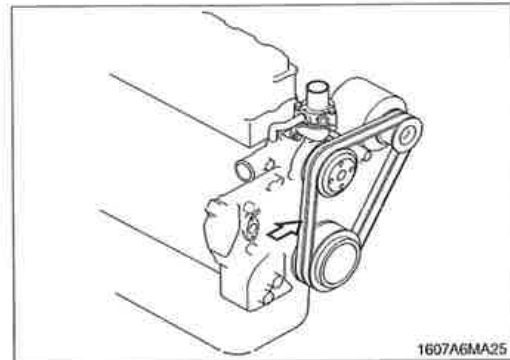

- (2) Inspect the drive for damage.

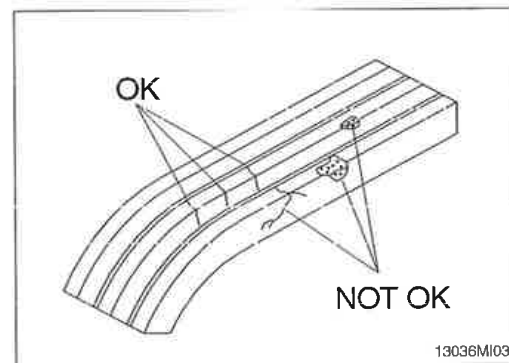

- (3) Inspect the drive belt, tension bearing and fan hub.

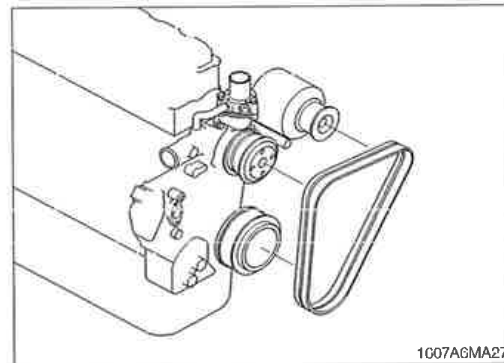

8) INSPECTION OF COOLING FAN

- ⚠ Personal injury can result from a fan blade failure. Never pull or pry on the fan. This can damage the fan blade and cause fan failure.
 - ※ Rotate the crankshaft by using the engine barring gear.
 - ※ A visual inspection of the cooling fan is required daily.
- Check for cracks, loose rivets, and bent or loose blades.
- Check the fan to make sure it is securely mounted. Tighten the capscrews if necessary.
- Replace any fan that is damaged.

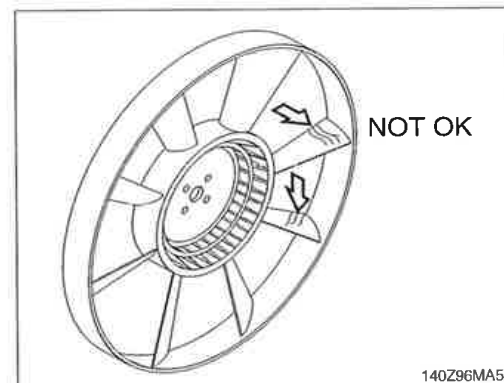

9) CLEANING OF AIR CLEANER

(1) Primary element

- ① Loosen the clamps and remove the element.
 - ② Clean the inside of the body.
 - ③ Clean the element with pressurized air.
 - Remove the dust inside of the element by the pressurized air (below 3 kgf/cm², 40 psi) forward and backward equally.
 - ④ Inspect for cracks or damage of element by putting a light bulb inside of the element.
 - ⑤ Insert element and tighten wing nut.
- ※ Replace the primary element after 4 times cleanings.

(2) Safety element

- ※ Replace the safety element only when the primary element is cleaned for the 4 times.
- ※ Always replace the safety element. Never attempt to reuse the safety element by cleaning the element.

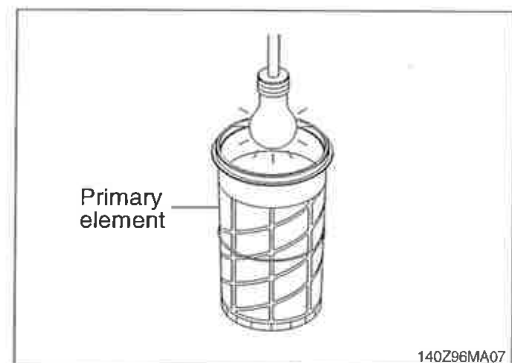
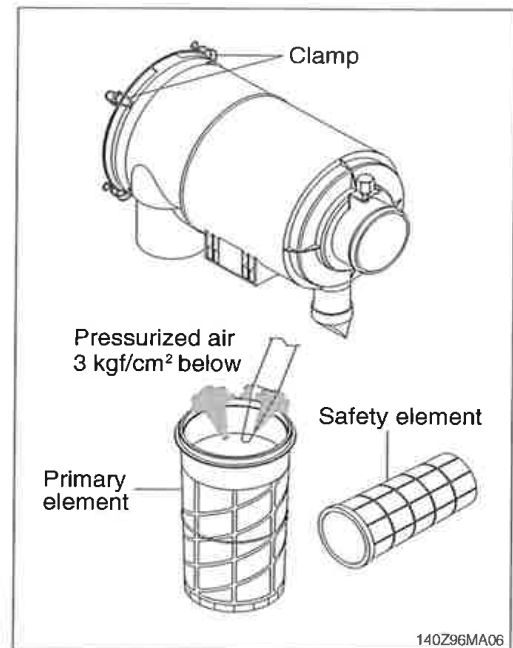

10) FUEL TANK

- (1) Fill fuel fully when system the operation to minimize water condensation, and check it with fuel gauge before starting the machine.
 - (2) Drain the water and sediment in the fuel tank by opening the drain cock.
 - ※ Be sure to LOCK the cap of fuel tank.
 - ※ Remove the strainer of the fuel tank and clean it if contaminated.
- ▲ Stop the engine when refueling.
All lights and flames shall be kept at a safe distance while refueling.

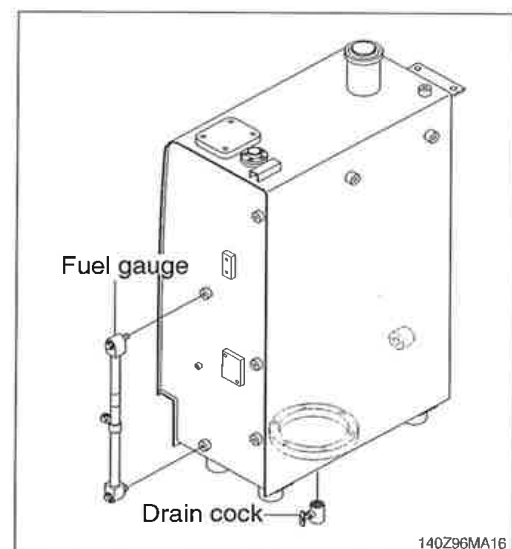



11) PREFILTER

- ※ Inspect or drain the collection bowl of water daily and replace the element every 500hours.

(1) Drain water

- ① Open bowl drain valve to evacuate water.
- ② Close drain valve.

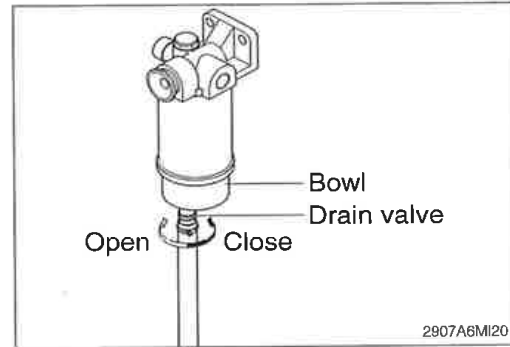

(2) Replace element

- ① Drain the unit of fuel. Follow "Drain water" instructions above.
- ② Remove element, fuel warmer and bowl from filter head.
- ※ The bowl is reusable, do not damage or discard.
- ③ Separate element from bowl. Clean bowl and seal gland.

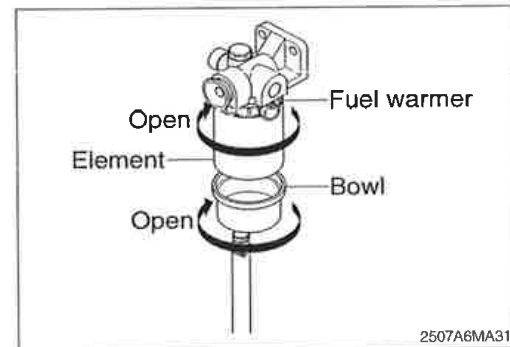

- ④ Lubricate new bowl seal with clean fuel or motor oil and place in bowl gland.
- ⑤ Attach bowl to new element firmly by hand.
- ⑥ Lubricate new element seal and place in element top gland.
- ⑦ Attach the element, fuel warmer and bowl to the head.

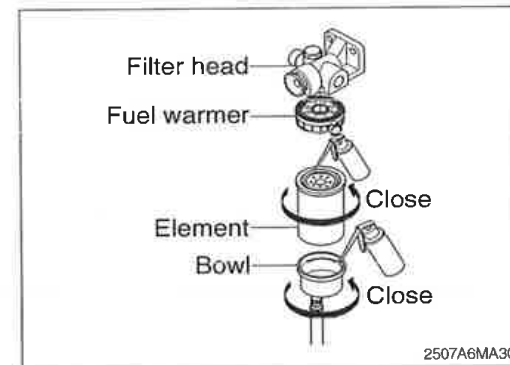

12) REPLACEMENT OF FUEL FILTER

- (1) Clean around the filter head, remove the filter with a filter wrench and clean the gasket surface.
 - (2) Apply a clean fuel oil to the gasket.
 - (3) Apply engine oil on the gasket of filter when mounting, and tighten 3/4 to 1 turn more after the gasket touches the filter head.
 - (4) Relieve the air by plug after mounting.
- ※ When installing the fuel filter, do not use a filter wrench. Tighten the fuel filter by hand.
 - ※ Check for fuel leakage after the engine starts. If air is in the fuel system, the engine will not start. Start engine after bleeding the air according to the method of bleeding air.

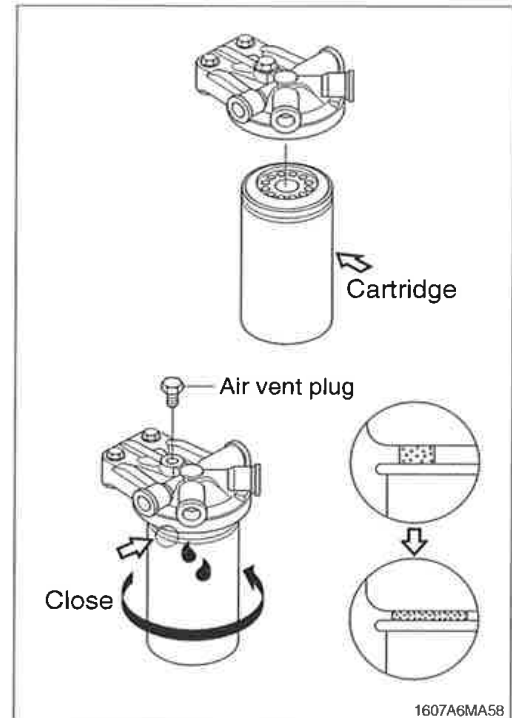

13) BLEEDING THE FUEL SYSTEM

- (1) Loosen fuel supply line plug at the outlet of prefilter.
- (2) Do hand-priming the lift pump repeatedly until air bubbles comes out from fuel supply line completely.
- (3) Tighten fuel supply line to its origin position.

⚠ The fuel pump, high-pressure fuel lines, and fuel rail contain very high-pressure fuel. Do not loosen any fittings while the engine is running. Personal injury and property damage can result. Wait at least 10 minutes after shutting down the engine before loosening any fittings in the high-pressure fuel system to allow pressure to decrease to a lower level.

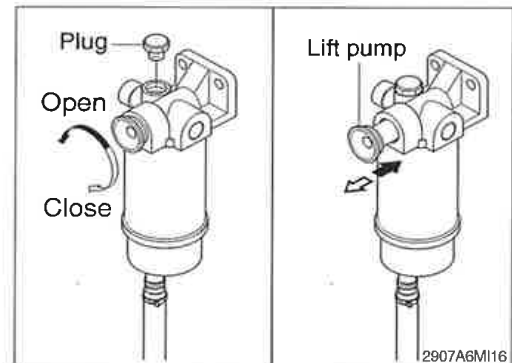

14) LEAKAGE OF FUEL

- ▲ Be careful and clean the fuel hose, injection pump, fuel filter and other connections as the leakage from these part can cause fire.

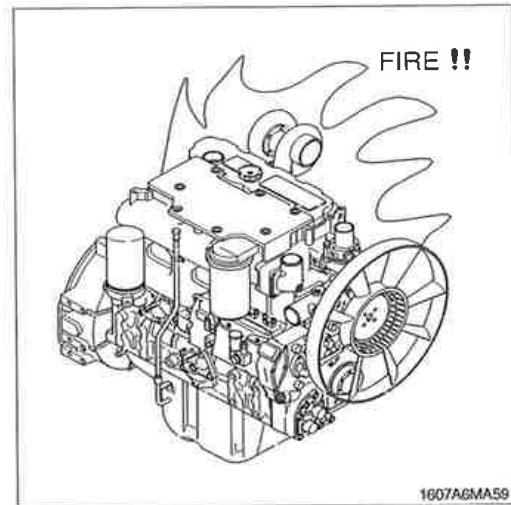

15) HYDRAULIC OIL CHECK

- (1) Stop the engine after retract the arm and bucket cylinders, then lower the boom and set the bucket on the ground at a flat location as in the illustration.
- (2) Check the oil level at the level gauge of hydraulic oil tank.
- (3) The oil level is normal if between the red lines.

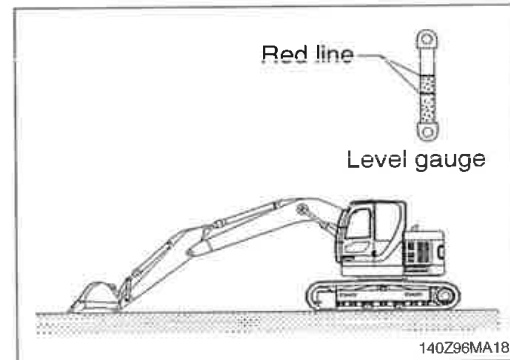

16) FILLING HYDRAULIC OIL

- (1) Stop the engine to the position of level check.
- (2) Loosen the cap and relieve the pressure in the tank by pushing the top of the air breather.
- (3) Remove the breather on the top of oil tank and fill the oil to the specified level.
 - Tightening torque : $1.44 \pm 0.3 \text{ kgf} \cdot \text{m}$
($10.4 \pm 2.1 \text{ lbf} \cdot \text{ft}$)
- (4) Start engine after filling and operate the work equipment several times.
- (5) Check the oil level at the level check position after engine stops.

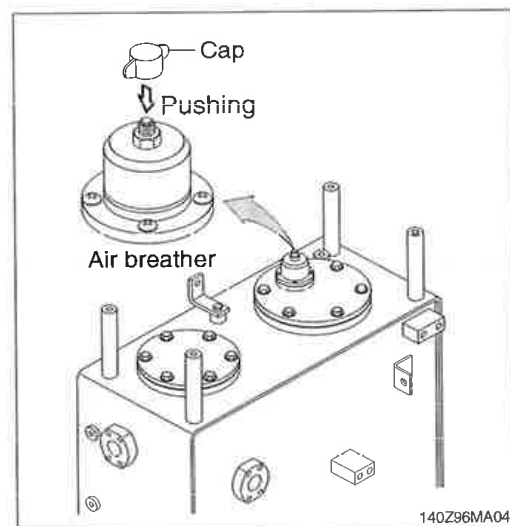

17) CHANGE HYDRAULIC OIL

- (1) Lower the bucket on the ground pulling the arm and bucket cylinder to the maximum.
- (2) Loosen the cap and relieve the pressure in the tank by pushing the top of the air breather.
- (3) Remove the cover.
 - Tightening torque : $6.9 \pm 1.4 \text{ kgf} \cdot \text{m}$
($50 \pm 10 \text{ lbf} \cdot \text{ft}$)
- (4) Prepare a suitable container.
- (5) To drain the oil loosen the drain plug at the bottom of the oil tank.
- (6) Fill proper amount of recommended oil.
- (7) Put the breather in the right position.
- (8) Bleed air hydraulic pump loosen the air breather at top of hydraulic pump assembly.
- (9) Start engine and run continually. Release the air by full stroke of each control lever.

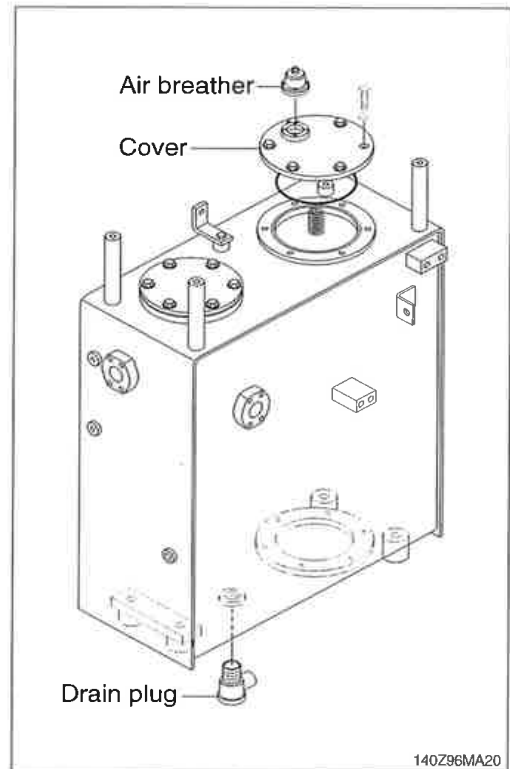

18) CLEAN SUCTION STRAINER

Clean suction strainer as follows paying attention to the cause to be kept during oil filling.

- (1) Remove the cover.
 - Tightening torque : $6.9 \pm 1.4 \text{ kgf} \cdot \text{m}$
($50 \pm 10 \text{ lbf} \cdot \text{ft}$)
 - (2) Pull out the strainer in the tank.
 - (3) Wash the foreign material on the suction strainer with gasoline or cleaning oil.
 - (4) Replace the suction strainer if it is damaged.
 - (5) Assemble with reverse order of disassembly. Be sure to install a new O-ring and reinsert in the oil tank.
- ※ Loosen the bolt slowly at the cover can be spring out by the spring when removing it.

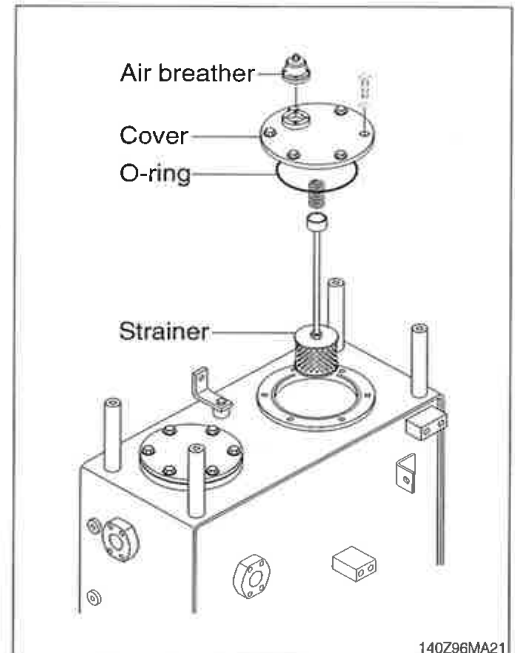

19) REPLACEMENT OF RETURN FILTER

Replace as follows paying attention to the cause to be kept during the replacement.

- (1) Remove the cover.
 - Tightening torque : $6.9 \pm 1.4 \text{ kgf} \cdot \text{m}$
($50 \pm 10 \text{ lbf} \cdot \text{ft}$)
- (2) Remove the spring, by-pass valve, and return filter in the tank.
- (3) Replace the element with new one.

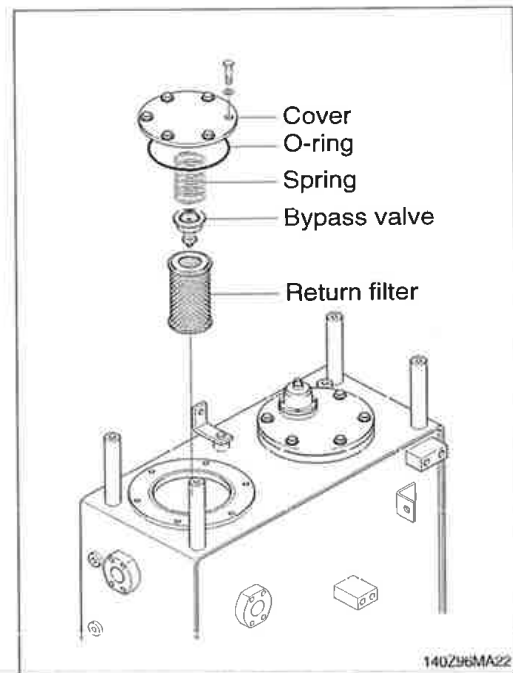

20) REPLACEMENT OF ELEMENT IN HYDRAULIC TANK BREATHER

- (1) Loosen the cap and relieve the pressure in the tank by pushing the top of the air breather.
- (2) Loosen the lock nut and remove the cover.
- (3) Pull out the filter element.
- (4) Replace the filter element new one.
- (5) Reassemble by reverse order of disassembly.
 - Tightening torque : $0.2 \sim 0.3 \text{ kgf} \cdot \text{m}$
($1.4 \sim 2.1 \text{ lbf} \cdot \text{ft}$)

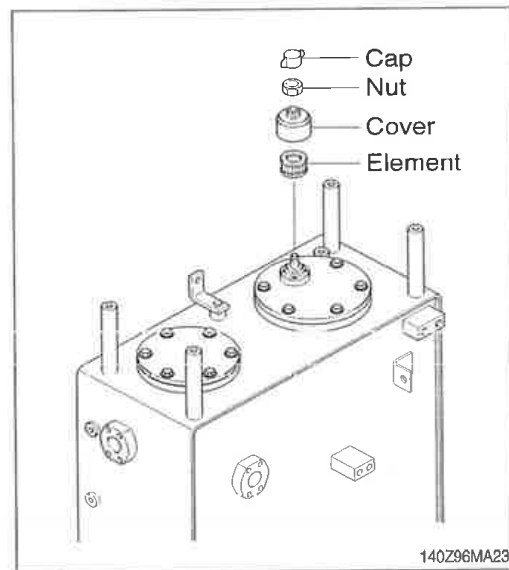

21) REPLACE OF DRAIN FILTER CARTRIDGE

Clean the dust around filter and replace with new one after removing the cartridge.

- ※ Tighten about 2/3 turn more after the gasket of cartridge contacts seal side of filter body for mounting.
- ※ Change cartridge after initial 250 hours of operation. Thereafter, change cartridge every 1000 hours.

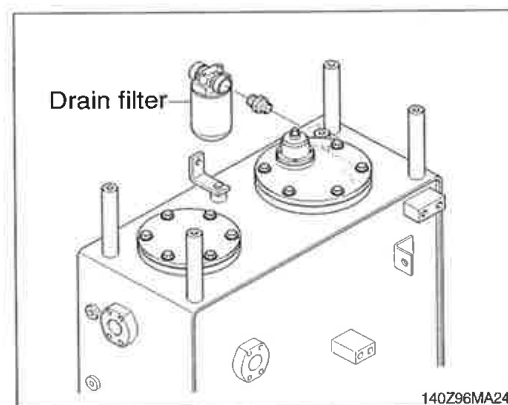



22) REPLACE OF PILOT LINE FILTER

- (1) Loosen the nut positioned on the filter body.
 - (2) Pull out the filter element and clean filter housing.
 - (3) Install the new element and tighten using specified torque.
- ※ **Change cartridge after initial 250 hours of operation. Thereafter, change cartridge every 1000 hours.**

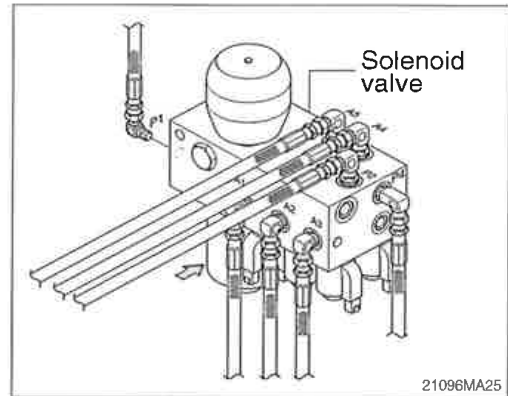

23) CHECK THE SWING REDUCTION GEAR OIL

- (1) Pull out the dipstick and clean it.
- (2) Insert it again.
- (3) Pull out one more time to check the oil level and fill the oil if the level is not sufficient.

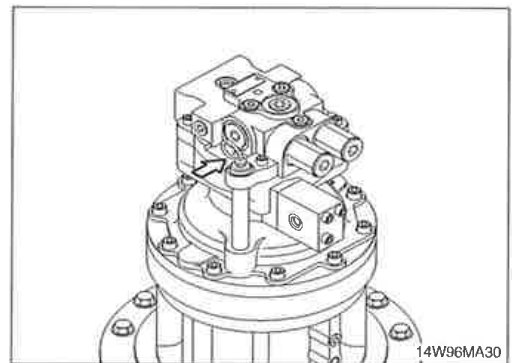

24) CHANGE SWING REDUCTION GEAR OIL

- (1) Raise the temperature of oil by swinging the machine before replace the oil and park the machine on the flat ground.
- (2) Prepare a proper container.
- (3) Remove the cap and open the drain valve.
- (4) Clean around the valve and close the drain valve and cap.
- (5) Fill proper amount of recommended oil.
 - Amount of oil : 2.5 l (0.7 U.S.gal)

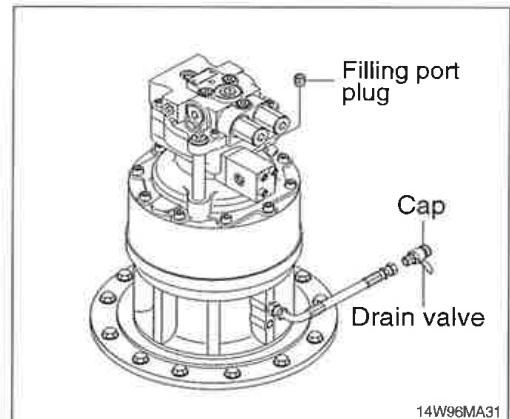

25) LUBRICATE BEARING OF OUTPUT SHAFT IN REDUCTION GEAR

- (1) Remove air vent plug.
- (2) Lubricate NLGI No.2 with grease gun until comes out new grease from air vent port.
 - Amount of oil : 0.32 kg (0.7 lb)

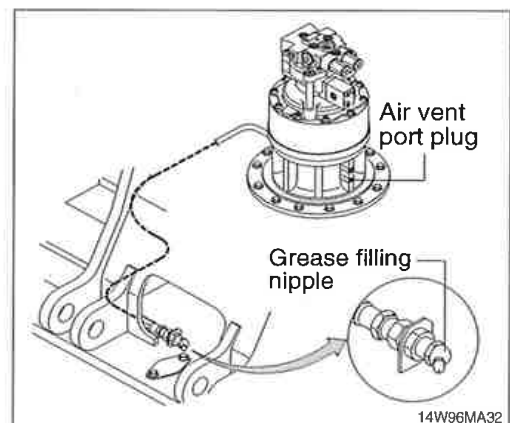

26) LUBRICATE SWING BEARING

- (1) Grease at 3 fitting.
- ※ Lubricate every 50 hours.

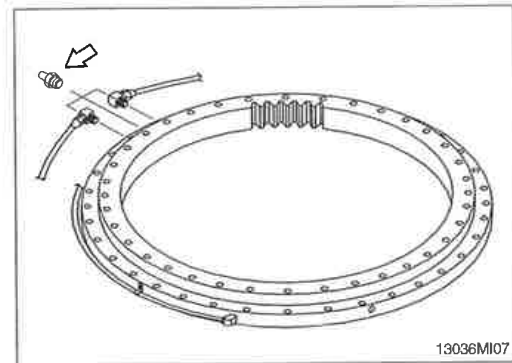

27) SWING GEAR AND PINION

(1) Drain old grease

- ① Remove under cover of lower frame.
- ② Remove drain cover of lower frame.
- ③ Remove filler cover of upper frame.
- ④ Operate full turn (360°) of swing several times.

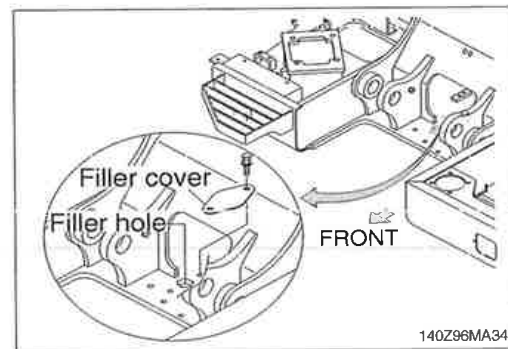

(2) Refill new grease

- ① Install drain cover.
- ② Fill with new grease.
- ③ Install filler cover.
- Capacity : 7.4 kg (16.3 lb)

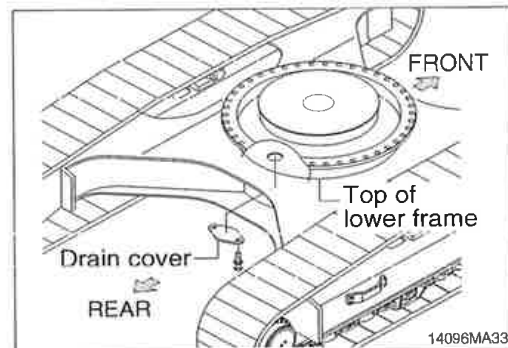

28) CHECK THE TRAVEL REDUCTION GEAR OIL

- (1) Operate the machine to the position of drain plug down to the flat ground.
- (2) Loosen the level plug and check the oil level.
If the level is at the hole of the plug, it is normal.
Fill the oil if it is not sufficient.
- Amount of gear oil : 1.8 l (0.48 U.S.gal)

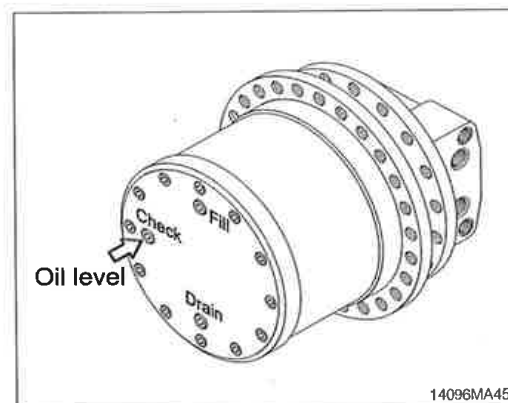

29) CHANGE OF THE TRAVEL REDUCTION GEAR OIL

- (1) Raise the temperature of the oil by traveling machine first.
- (2) Stop when the position of the drain plug is down.
- (3) Loosen the level plug and then the drain plug.
- (4) Drain the oil to adequate container.
- (5) Tighten the drain plug and fill specified amount of oil at filling port.
- (6) Tighten the level plug and travel slowly to check if there is any leakage of oil.

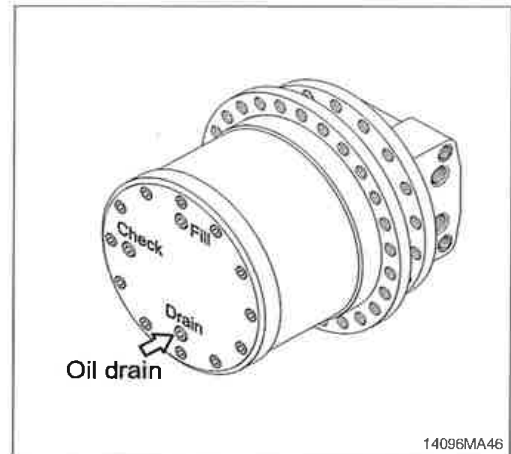

30) LUBRICATE RCV LEVER

Remove the bellows and with a grease gun grease the joint part (A) and sliding parts (B).

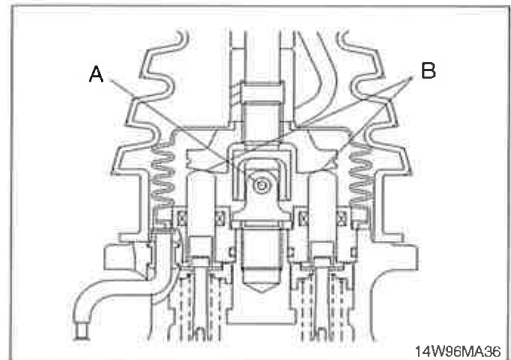

31) ADJUSTMENT OF TRACK TENSION

- ※ It is important to adjust the tension of track properly to extend the lifetime of track and traveling device.
- ※ The wear of pins and bushings on the undercarriage will vary with the working conditions and soil properties.

It is thus necessary to continually inspect the track tension so as to maintain the standard tension on it.

- (1) Raise the chassis with the boom and arm.
 - (2) Measure the distance between bottom of track frame on track center and track of shoe.
- ※ Remove mud with rotating the track before measuring.

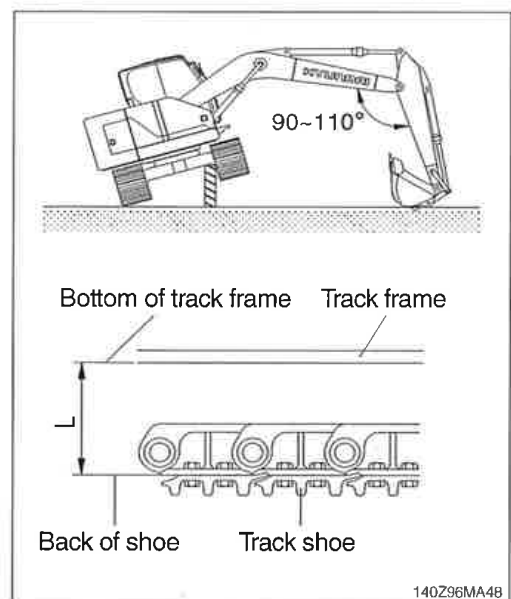



(3) If the tension is tight, drain the grease in the grease nipple and if the tension is loose, charge the grease.

- ▲ **Personal injury or death can result from grease under pressure.**
- ▲ **When loosening the grease nipple, do not loosen more than one turn as there is a danger of a spring coming out of the nipple because of the high pressure inside.**
- ※ **When the grease is drained, move the track to the forward and backward slightly.**
If the track tension is loose even after the grease is charged to the maximum, change the pins and bushings as there are worn seriously.

Length (L)	
270~300 mm	10.6~11.8"



32) REPLACEMENT OF BUCKET

⚠ When knocking the pin in with a hammer, metal particles may fly and cause serious injury, particularly if they get into your eyes. When carrying out this operation, always wear goggles, helmet, gloves, and other protective equipment.

- ※ When the bucket is removed, place it in a stable condition.
- ※ When performing joint work, make sure signals to each other and work carefully for safety's sake.

- (1) Lower the bucket on the ground as the picture shown in the right.
- (2) Lock the safety lever to the LOCK position and stop the engine.
- (3) Remove the stopper bolts (1) and nuts (2), then remove pins (3, 4) and remove the bucket.
 - ※ When removing the pins, place the bucket so that it is in light contact with the ground.
 - ※ If the bucket is lowered strongly to the ground, the resistance will be increased and it will be difficult to remove the pins.
 - ※ After remove the pins, make sure that they do not become contaminated with sand or mud and that the seals of bushing on both sides do not become damaged.
- (4) Align the arm with holes (A) and the link with holes (B), then coat with grease and install pins(3, 4)
 - ※ When installing the bucket, the O-rings are easily damaged, so fit the O-rings on the boss of the bucket as shown in the picture. After knocking the pin, move the O-ring down to the regular groove.
- (5) Install the stopper bolt (1) and nuts (2) for each pin, then grease the pin.

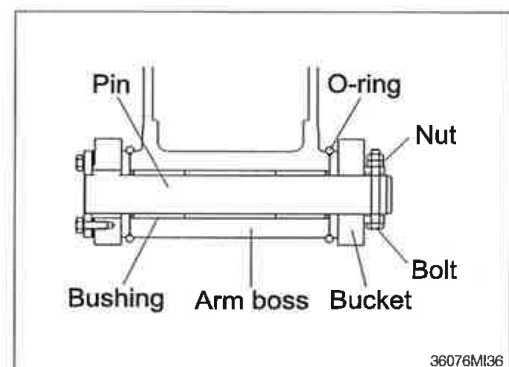
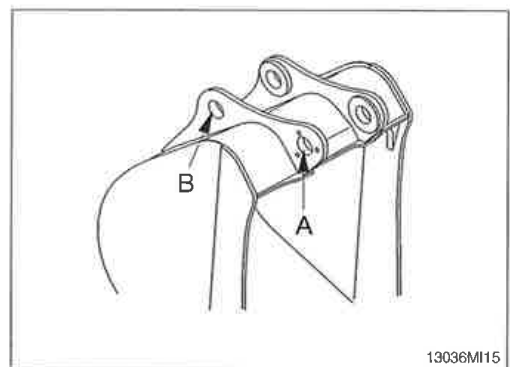
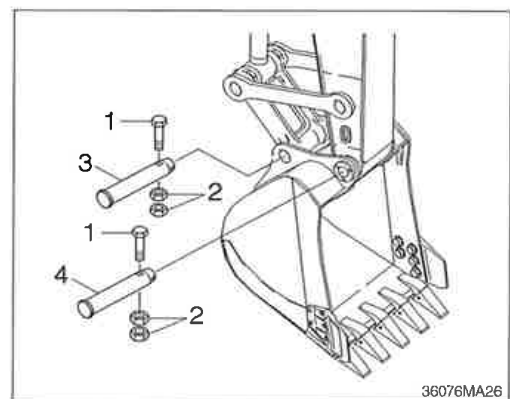
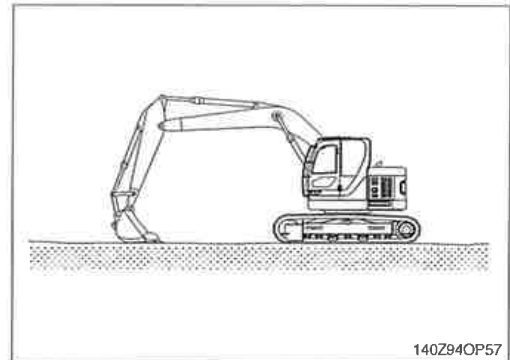

33) REPLACEMENT OF BUCKET TOOTH

(1) Timing of replacement

- ① Check wearing condition as shown in the illustration and replace tooth tip before adapter starts to wear.
- ② If excessive use, tooth adapter has worn out, replacement may become impossible.

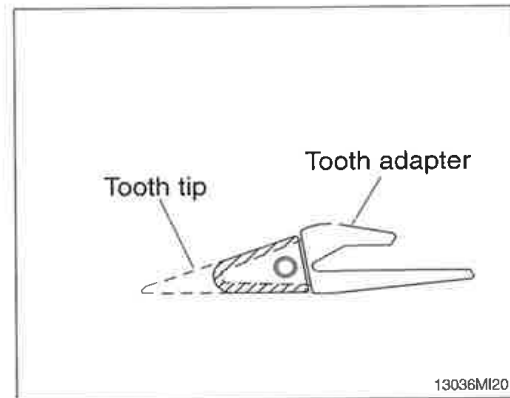

(2) Instructions for replacement

- ① Pull out pin by striking pin with punch or hammer, avoiding damage to locking washer.
 - ② Remove dust and mud from surface of tooth adapter by using knife.
 - ③ Place locking washer in its proper place, and fit tooth tip to adapter.
 - ④ Insert pin until locking washer is positioned at tooth pin groove.
- ⚠ Personal injury can result from bucket falling.
- ⚠ Block the bucket before changing tooth tips or side cutters.

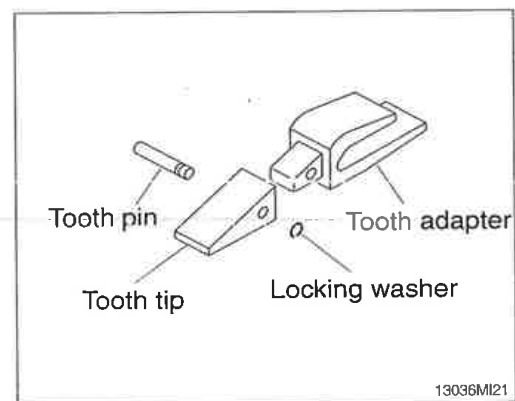



34) ADJUSTMENT OF BUCKET CLEARANCE

- (1) Lower the bucket on the ground as the picture shown in the right.
- (2) Swing to the left and keep the arm boss to be contact to the bucket left.
- (3) Lock the safety lever to the LOCK position and stop the engine.
- (4) Measure the clearance (A) between bucket and arm boss. This is the total clearance.

(5) Adjusting

- ① Loosen bolt (2), and remove washer (3), plate (1) and shim (4).
- ② Remove the shim equivalent value with measuring value.
- ③ Assemble the parts in the reverse order of removal.
 - Tightening torque : $29.6 \pm 3.2 \text{ kgf} \cdot \text{m}$
($214.0 \pm 23.1 \text{ lbf} \cdot \text{ft}$)
 - Normal clearance : $0.5 \sim 1.0 \text{ mm}$
($0.02 \sim 0.04 \text{ in}$)

※ If the bucket is not adjusted correctly, noise and vibration created during operation, and damaged O-ring, pin and bushing quickly.

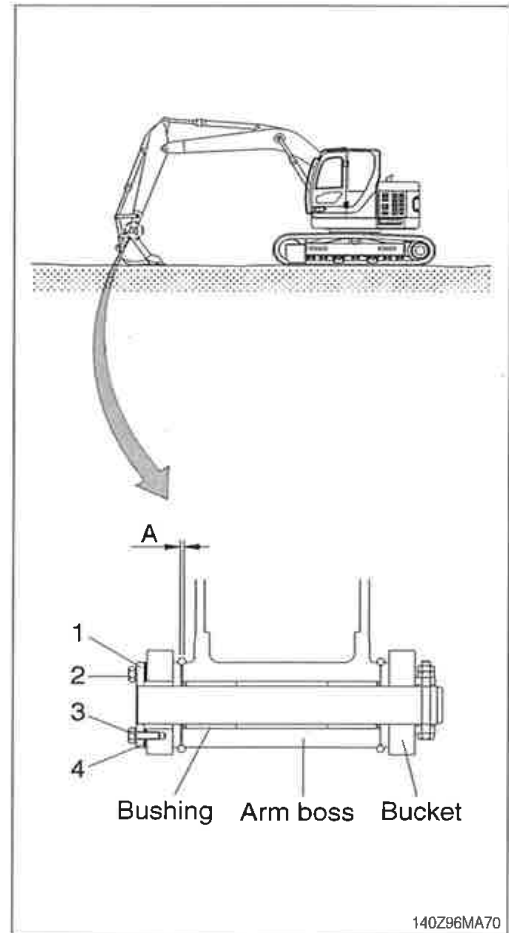

140Z96MA70



35) LUBRICATE PIN AND BUSHING

(1) Lubricate to each pin of working device

Lubricate the grease to the grease nipple according to the lubricating interval.

No.	Description	Qty
1	Lubrication manifold at boom	5
2	Boom cylinder pin	2
3	Boom and arm connection pin	1
4	Arm cylinder pin (rod side)	1
5	Bucket cylinder pin (head side, rod side)	2
	Bucket link (control rod)	3
	Arm and control link connection pin	1
	Arm and bucket connection pin	1
6	Boom rear bearing center	1

※ Shorten lubricating interval when working in the water or dusty place.

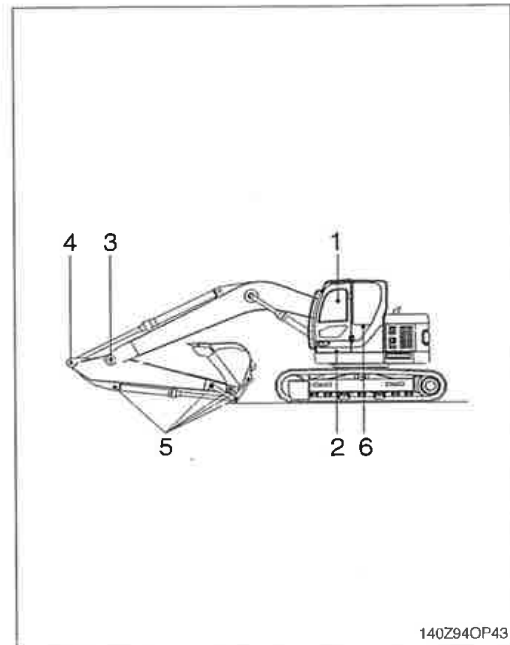

(2) Dust seals are mounted on the rotating part of working device to extend the lubricating interval.

※ Mount the lip to be faced outside when replace the dust seal.

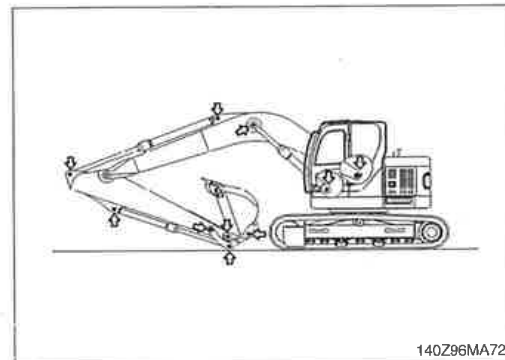

※ If it is assembled in wrong direction, it will cause fast wear of pin and bushing, and create noise and vibration during operation.

※ Assemble the seal same direction with picture and use with plastic hammer when replace.

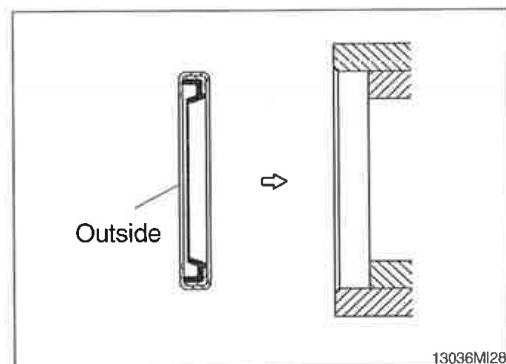



7. ELECTRICAL SYSTEM

1) WIRING, GAUGES

Check regularly and repair loose or malfunctioning gauges when found.

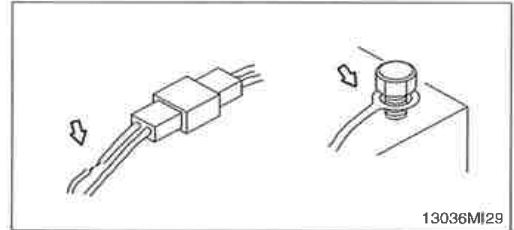

13036MI29

2) BATTERY

(1) Clean

- ① Wash the terminal with hot water if it is contaminated, and apply grease to the terminals after washing.
- ⚠ Battery gas can explode. Keep sparks and flames away from batteries.
- ⚠ Always wear protective glasses when working with batteries.
- ⚠ Do not stain clothes or skin with electrolyte as it is acid.
Be careful not to get the electrolyte in eyes.
Wash with clean water and go to the doctor if it enters the eyes.



36070FW05

(2) Recycle

- Never discard a battery.
Always return used batteries to one of the following locations.
- A battery supplier
 - An authorized battery collection facility
 - Recycling facility

(3) Method of removing the battery cable

Remove the cable from the ground connection first (⊖ terminal side) and reconnect it last when reassembling.

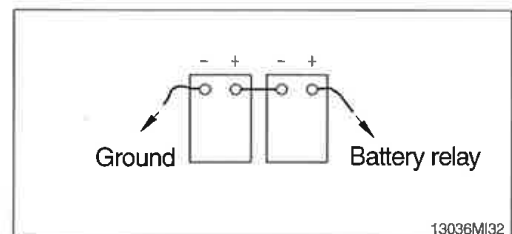

13036MI32

3) STARTING THE ENGINE WITH A BOOSTER CABLE

Keep following order when you are going to start engine using booster cable.

(1) Connection of booster cable

- ※ Use the same capacity of battery for starting.
- ① Make sure that the starting switches of the normal machine and trouble machine are both at the OFF position.
- ② Connect the red terminal of booster cable to the battery (+) terminal between exhausted and new battery.
- ③ Connect the black terminal of the booster cable between new battery (-) terminal and chassis of trouble machine.
- ※ Keep firmly all connection, the spark will be caused when connecting finally.

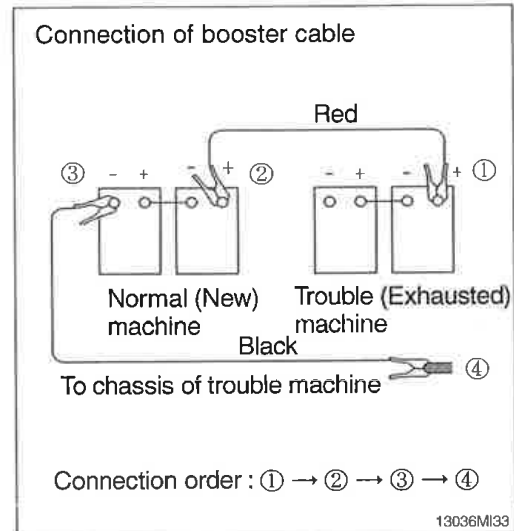

(2) Starting the engine

- ① Starting the engine of the normal machine and keep it to run at high idle.
- ② Start engine of the trouble machine with starting switch.
- ③ If you can not start it by one time, restart the engine after 2 minutes.

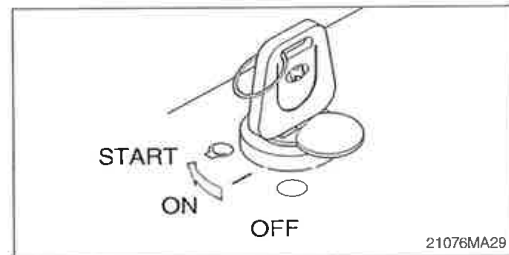

(3) Taking off the booster cable

- ① Take off the booster cable (black).
- ② Take off the booster cable (red) connected to the (+) terminal.
- ③ Run engine with high idle until charging the exhausted battery by alternator, fully.
- ▲ Explosive gas is generated while using the battery or charging it. Keep away flame and be careful not to cause the spark.
- ※ Charge the battery in the well ventilated place.
- ※ Place the machine on the earth or concrete. Avoid charging the machine on the steel plate.
- ※ Do not connect (+) terminal and (-) terminal when connecting booster cable because it will be shorted.

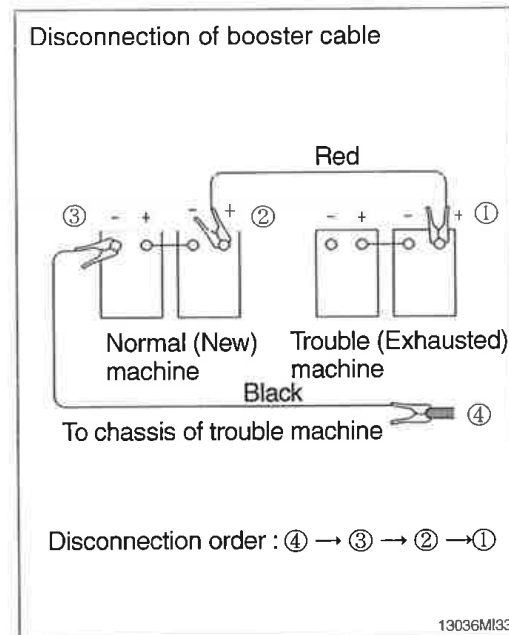



(4) Welding repair

Before start to welding, follow the below procedure.

- ① Shut off the engine and remove the starting switch.
 - ② Disconnect ground cable from battery by master switch.
 - ③ Before carrying out any electric welding on the machine, the battery cables should be disconnected and the connectors pulled out of the electronic control units (MCU, cluster etc).
 - ④ Connect the earth (ground) lead of the welding equipment as close to the welding point as possible.
- ※ Do not weld or flame cut on pipes or tubes that contain flammable fluids. Clean them thoroughly with nonflammable solvent before welding or flame cutting on them.
- ⚠ Do not attempt to welding work before carry out the above.
If not, it will caused serious damage at electric system.

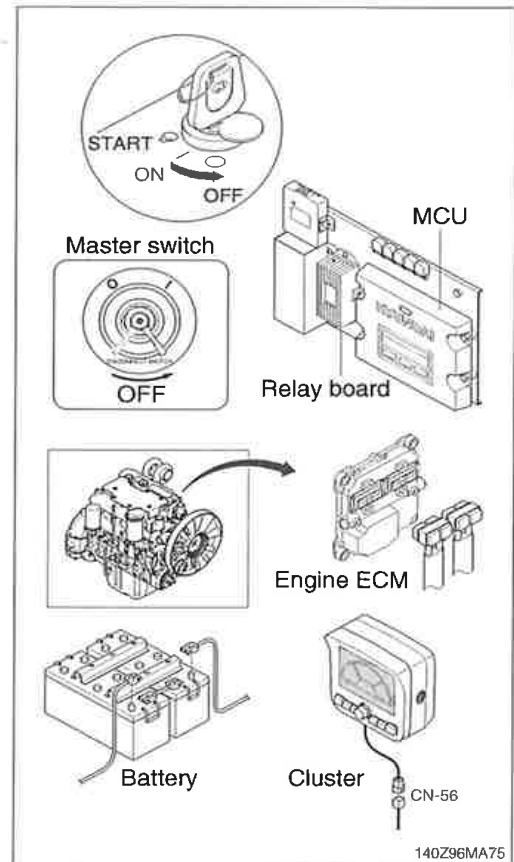

8. AIR CONDITIONER AND HEATER

1) CLEAN AND REPLACE OF FRESH AIR FILTER

※ Always stop the engine before servicing.

(1) Open the LH side cover.

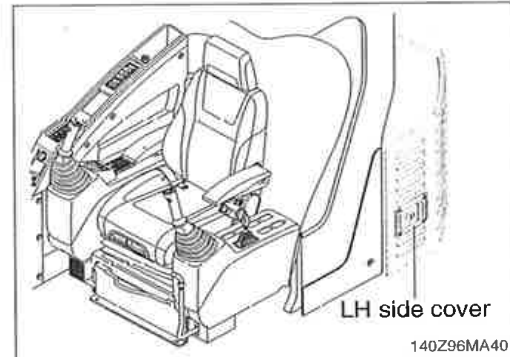

(2) Remove the fresh air filter.

※ When installing a filter, be careful not to change the filter direction.

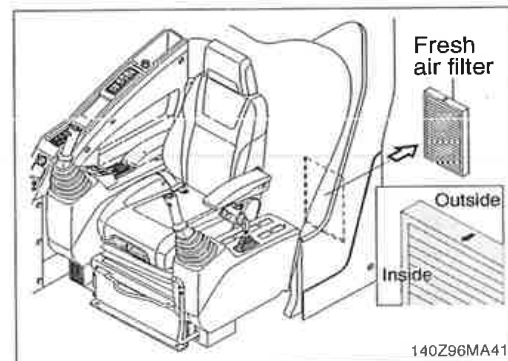

(3) Clean the filter using a pressurized air (below 2 kgf/cm², 28 psi).

△ When using pressurized air, be sure to wear safety glasses.

(4) Inspect the filter after cleaning. If it is damaged or badly contaminated, use a new filter.

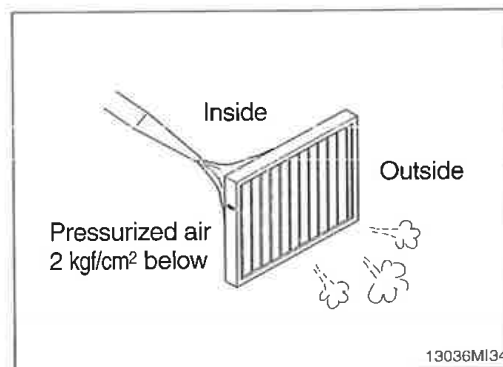

2) CLEAN AND REPLACE OF RECIRCULATION FILTER

※ Always stop the engine before servicing.

(1) Move seat and console box to arrow direction using the adjust lever.

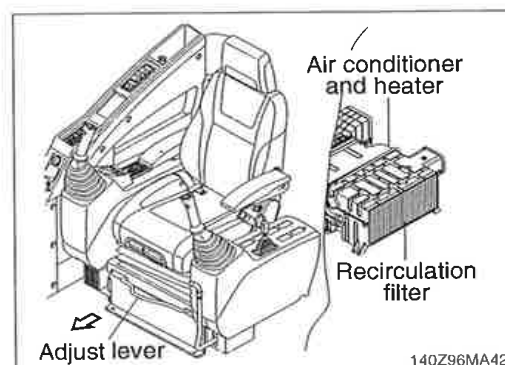



(2) Remove recirculation filter.

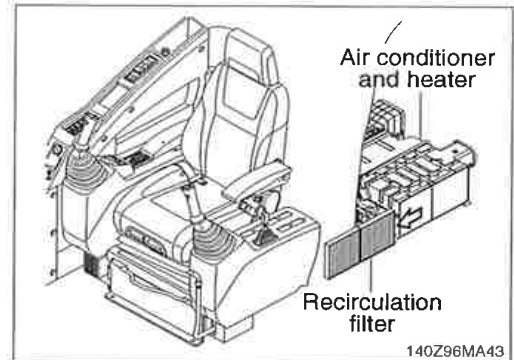

(3) Clean the recirculation filter using a pressurized air (below 2 kgf/cm², 28 psi) or washing with water.

△ When using pressurized air, be sure to wear safety glasses.

※ Dry off after washing with water.

(4) Inspect the filter after cleaning. If it is damaged or badly contaminated, use a new filter.

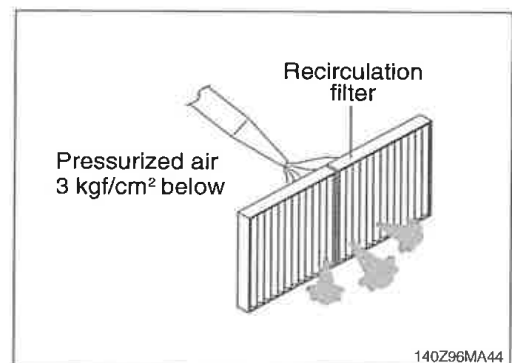

3) PRECAUTIONS FOR USING AIR CONDITIONER

- (1) When using the air conditioner for a long time, open the window once every one hour.
- (2) Be careful not to overcool the cab.
- (3) The cab is properly cooled if the operator feels cool when entering there from outside (about 5°C lower than the outside temperature).
- (4) When cooling, change air occasionally.

4) CHECK DURING SEASON

Ask the service center for replenishment of refrigerant or other maintenance service so that the cooling performance is not damaged.

5) CHECK DURING OFF-SEASON

Operate the air conditioner 2 or 3 times a month (each for a few minutes) to avoid loss of oil film in the compressor.





TROUBLESHOOTING GUIDE

1. ENGINE

※ This guide is not intended to cover every conditions, however many of the more common possibilities are listed.

Trouble	Service	Remark
The engine oil pressure lamp lights ON when engine speed is raised after completion of warm up.	<ul style="list-style-type: none"> • Add the oil to the specified level. • Replace the oil filter cartridge. • Check oil leakage from the pipe or the joint. • Replace the monitor. 	
Steam is emitted from the top part of the radiator (the pressure valve). Coolant level warning lamp lights ON.	<ul style="list-style-type: none"> • Supply the coolant and check leakage. • Adjust fan belt tension. • Wash out inside of cooling system. • Clean or repair the radiator fin. • Check the thermostat. • Tighten the radiator cap firmly or replace the packing of it. • Replace the monitor. 	
The engine does not start when the starting motor is turned over.	<ul style="list-style-type: none"> • Add fuel. • Repair where air is leaking into fuel system. • Check the injection pump or the nozzle. • Check the valve clearance. • Check engine compression pressure. • In cold weather, check if fuel warmer system is working normal. 	Refer to the pages 3-23 and 4-4.
Exhaust gas is white or blue.	<ul style="list-style-type: none"> • Adjust to specified oil quantity. • Replace with specified fuel. 	
Exhaust gas occasionally turns black.	<ul style="list-style-type: none"> • Clean or replace the air cleaner element. • Check the nozzle. • Check engine compression pressure. • Clean or replace the turbocharger. 	
Combustion noise occasionally changes to breathing sound.	<ul style="list-style-type: none"> • Check the nozzle. 	
Unusual combustion noise or mechanical noise.	<ul style="list-style-type: none"> • Check with specified fuel. • Check over-heating. • Replace the muffler. • Adjust valve clearance. 	



2. ELECTRICAL SYSTEM

Trouble	Service	Remark
Lamp does not glow brightly even when engine runs at high speed. Lamp flickers while engine runs.	<ul style="list-style-type: none"> · Check for loose terminals and open-circuit wiring. · Adjust belt tension. 	
Battery charging lamp does not go out even when engine runs at high speed.	<ul style="list-style-type: none"> · Check the alternator. · Check and repair wiring. 	
Unusual noise is emitted from the alternator.	<ul style="list-style-type: none"> · Check the alternator. 	
Starting motor does not turn when starting switch is turned ON.	<ul style="list-style-type: none"> · Check and repair the wiring. · Charge the battery. · Check the starting motor. · Check the safety relay. 	
The pinion of the starting motor keeps going in and out.	<ul style="list-style-type: none"> · Charge the battery. · Check the safety relay. 	
Starting motor turns the engine sluggishly.	<ul style="list-style-type: none"> · Charge the battery. · Check the starting motor. 	
The starting motor disengages before the engine starts up.	<ul style="list-style-type: none"> · Check and repair the wiring. · Charge the battery. 	
The engine warming up lamp does not go ON.	<ul style="list-style-type: none"> · Check and repair wiring. · Check the monitor. 	
The engine oil pressure lamp does not light up when engine is stationary (when the starting switch is in ON position.)	<ul style="list-style-type: none"> · Check the monitor. · Check the caution lamp switch. 	
Battery charging lamp does not light up when the engine is stationary. (when the starting switch is in ON position.)	<ul style="list-style-type: none"> · Check the monitor. · Check and repair the wiring. 	



3. OTHERS

Trouble	Service	Remark
Track slip out of place. Excessive wear of the sprocket.	<ul style="list-style-type: none"> Adjust tension of track. 	
Bucket either rises slowly or not at all.	<ul style="list-style-type: none"> Add oil to specified level. 	
Slow speed of travel, swing, boom, arm and bucket.	<ul style="list-style-type: none"> Add oil to specified level. 	
Unusual noise emitted from pump.	<ul style="list-style-type: none"> Clean the hydraulic tank strainer. 	
Excessive oil temperature rise of hydraulic oil.	<ul style="list-style-type: none"> Clean the oil cooler. Adjust fan belt tension. Add oil to specified level. 	





HYDRAULIC BREAKER AND QUICK CLAMP

1. SELECTING HYDRAULIC BREAKER

- 1) Become familiar with the manual and select breakers suitable to machine specifications.
- 2) Make careful selection in consideration of oil quantity, pressure and striking force, to enable satisfied performance.
- 3) When apply a breaker to the machine, consult your local dealer of Hyundai for further explanation.

2. CIRCUIT CONFIGURATION

- 1) As for breaker oil pressure line, use extra spool of main control valve.
- 2) Set proper breaker pressure on load relief valve.
 - ※ The initial setting pressure of load relief valve for breaker is 210 bar.
- 3) The pressure of the ROBEX145CR-9 system is 350 kgf/cm² (4980 psi).

4) Adjusting oil quantity

- (1) Use the breaker mode from work tool of cluster. Use select switch to control the oil flow quantity.
 - Setting oil quantity (100 lpm)

Flow set

- Max flow : Set the maximum flow for the attachment.
- Flow level : Reduce the operating flow from maximum flow.
 - Breaker : Max 7 steps, reduced 10 lpm each step.

- (2) If the quantity of hydraulic oil is not controlled properly, it causes short lifecycle of the breaker and the machine by increased breaking force and count.

- 5) The accumulator should be used to the breaker charging and return line. If the accumulator is not used, it will be damage as the input wave is delivered.
 - ※ Keep the pressure pulsation of pump below 60 kgf/cm² (853 psi) by installing the accumulator.
- 6) Do not connect the breaker return line to the main control, but connect to the return line front of the cooler.
- 7) Do not connect the breaker return line to drain lines, such as of swing motor, travel motor or pump, otherwise they should be damaged.
- 8) One of spool of the main control valve should be connected to the tank.
- 9) Select the size of pipe laying considering the back pressure.
- 10) Shimless tube should be used for the piping. The hose and seal should be used Hyundai genuine parts.
- 11) Weld the bracket for pipe clamp to prevent damage caused by vibration.

Oil quantity setting





3. MAINTENANCE

1) MAINTENANCE OF HYDRAULIC OIL AND FILTER

- (1) As machine with an hydraulic breaker provides the hydraulic oil becomes severely contaminated.
- (2) So, unless frequently maintained, the machine may easily go out of order.
- (3) Inspect and maintain hydraulic oil and 4 kinds of filter elements in particular, in order to prolong machine life.

2) RELEASE THE PRESSURE IN BREAKER CIRCUIT

When breaker operating is finished, stop engine and push pedal or switch for breaker to release pressure in breaker circuit.

If pressure still remains, the lifetime of the diaphragm in the accumulator will be shortened.

- 3) Be careful to prevent contamination by dust, sand and etc.
If such pollution become mixed into the oil, the pump moving parts will wear abnormally, shorten lifetime and become damaged.
- 4) When operating breaker, bolts and nuts of main equipment may be loosened by vibration. So, it must be inspected periodically.

Service interval

unit : hours

Attachment	Operating rate	Hydraulic oil	Filter element
Breaker	100 %	600* ¹	200
		1000* ²	

*¹: Conventional hydraulic oil

*²: Hyundai genuine long life hydraulic oil

● **Replace following filter same time**

- Hydraulic return filter : 1 EA
- Pilot line filter : 1 EA
- Drain filter cartridge : 1 EA

Hyd oil change guide for hydraulic breaker

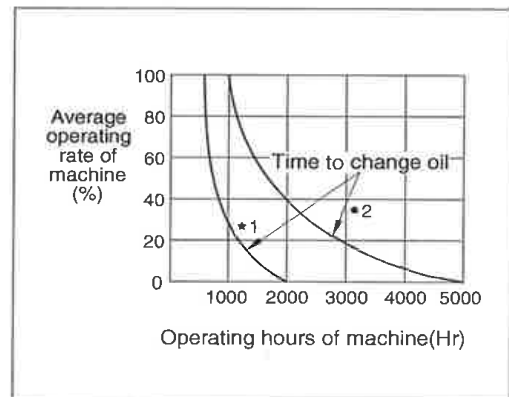

*¹: Conventional hydraulic oil

*²: Hyundai genuine long life hydraulic oil

4. PRECAUTIONS WHILE OPERATING THE BREAKER

1) DO NOT BREAK ROCK WHILE LOWERING

As the breaker is heavy in comparison with bucket, it must be operated slowly.

If breaker is rapidly pushed down, working device may be damaged.

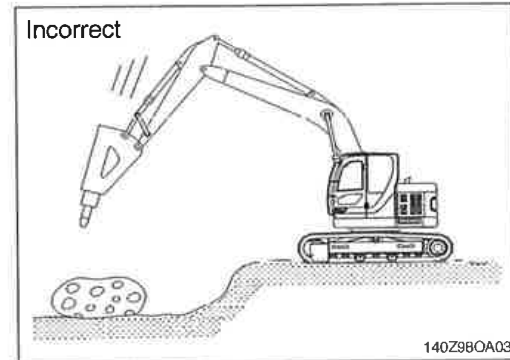

2) DO NOT USE BREAKER TO CARRY BROKEN STONE OR ROCK BY SWING OPERATING

This may damage the operation device and swing system.

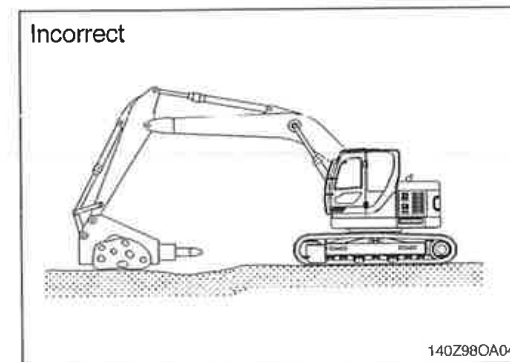

3) OPERATE BREAKER WITH A GAP IN EXCESS OF 100 mm (4 inches) FROM THE END OF THE STROKE TIP

If breaker is operated with the end tip, the cylinder may be damaged.

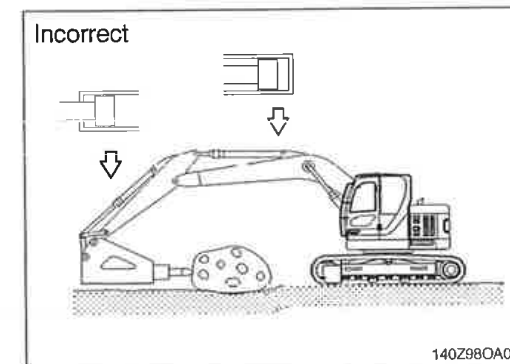

4) IF THE HYDRAULIC HOSES VIBRATE EXCESSIVELY

If the machine used in this condition continuously this will effect badly on the machine such as loosening bolt, oil leakage, damage of pump pipe and etc.

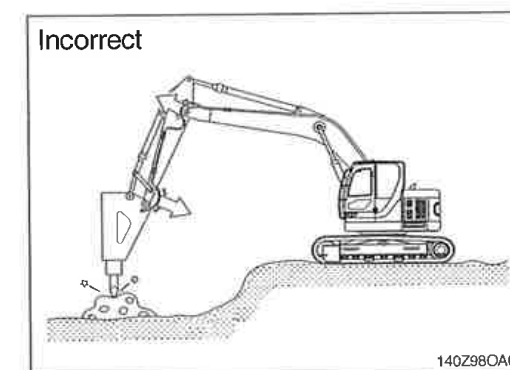



5) DO NOT CONTINUE TO WORKING OVER ONE MINUTE AT SAME POSITION OF BOOM AND ARM

This will increase the temperature of the oil, and cause problem in the accumulator and seals.

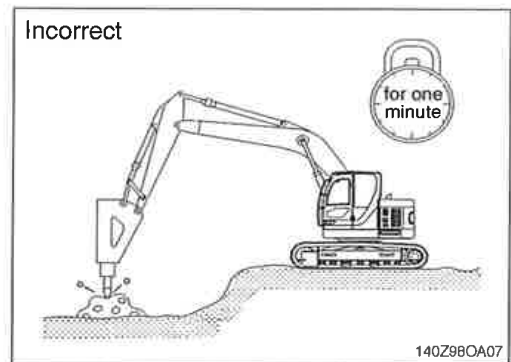

6) DO NOT MOVE MACHINE OR BREAKER WHILE STRIKING

Do not move hammer while striking.
This will cause damage to the working device and the swing system.

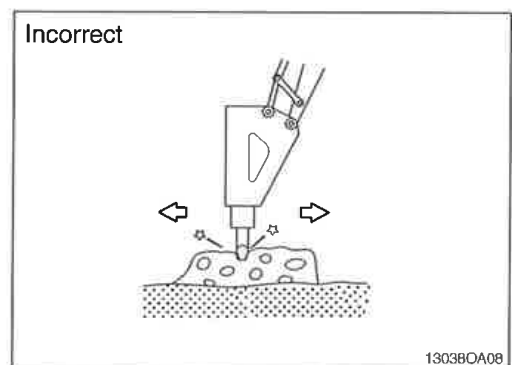

7) DO NOT WORK WHILE SWING STATE

Do not work while swing position of superstructure.
It cause the band of track shoe, oil leakage of roller.

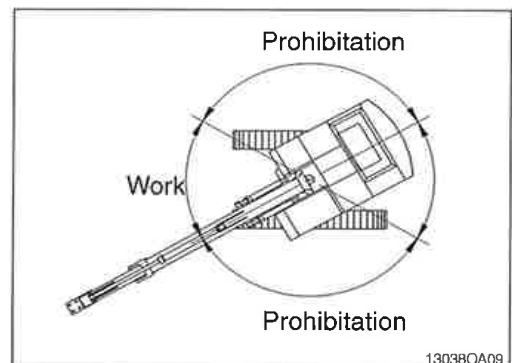

8) TAKE CARE OF CHISEL AND BOOM INTERFACE

Make sure of the arm and bucket control lever operation.

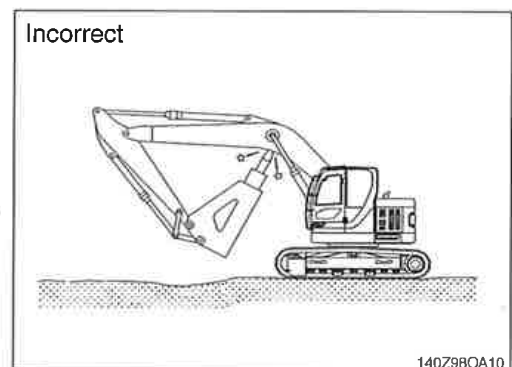

5. QUICK CLAMP

1) FIXING BUCKET WITH QUICK CLAMP

- (1) Before fixing bucket, remove safety pin of the moving hook.
- (2) Pulling safety button, press the quick clamp switch to unlock position. Then, the moving hook is placed on release position.

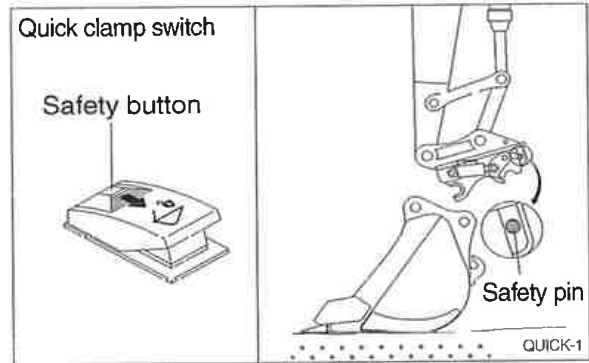

- (3) Aligning the arm and bucket, insert static hook of quick clamp to the bucket pin.

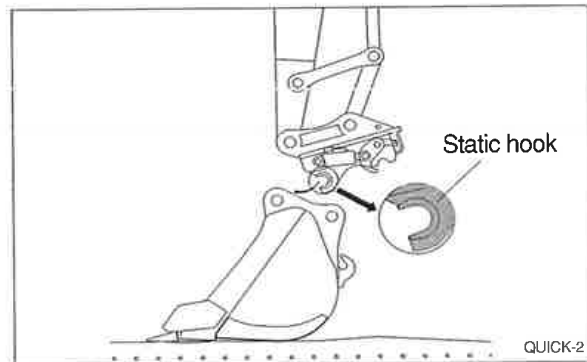

- (4) Operate RCV lever to bucket-in position. Then, the moving hook is coupled with the bucket link pin. Make sure that the moving hook is completely contacted with bucket link pin.

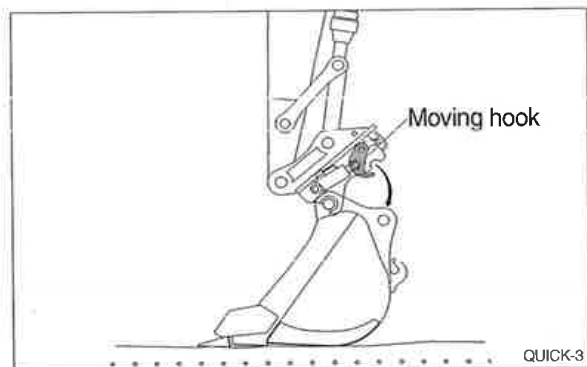

- (5) Push safety button to lock position. Operate RCV lever to bucket-in position.
 - ※ Be sure to check connection status between bucket pins and hooks of quick clamp.

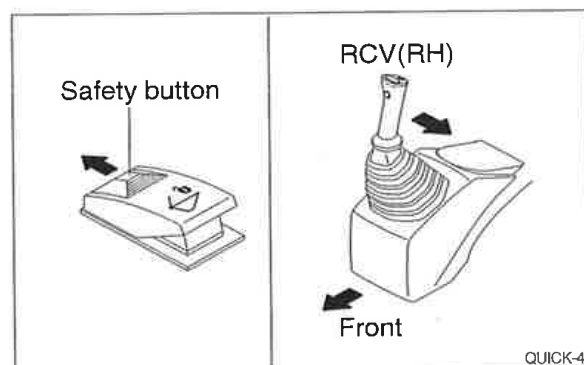

- (6) After checking the connection status between bucket pins and hooks of quick clamp, insert safety pin of moving hook to lock position.

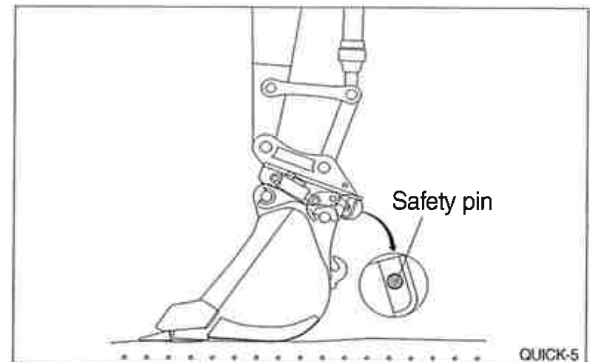

2) REMOVE BUCKET FROM QUICK CLAMP

Removing procedure is reverse of fixing.

3) PRECAUTION OF USING QUICK CLAMP

- ⚠ When operating the machine with quick clamp, confirm that the quick clamp switch is lock position and safety pin of moving hook is inserted.

Operating the machine with quick clamp switch unlocked and without safety pin of moving hook can cause the bucket to drop off and bring about the accident.

- ⚠ Serious injury or death can result from this accident.

- ⚠ Be careful to operate the machine equipped with quick clamp. The bucket may hit cab, boom and boom cylinders when it reaches vicinity of them.

HYUNDAI will not be responsible for any injury or damage in case that safety pin is not installed properly.

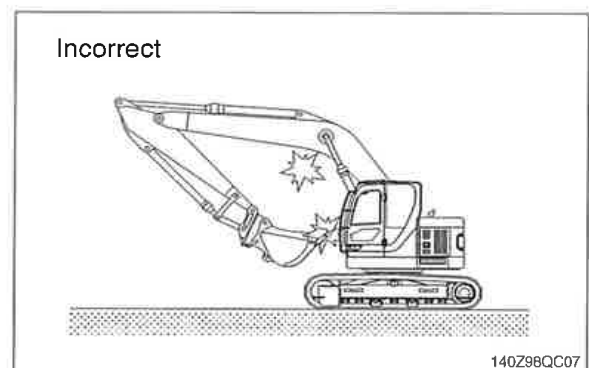
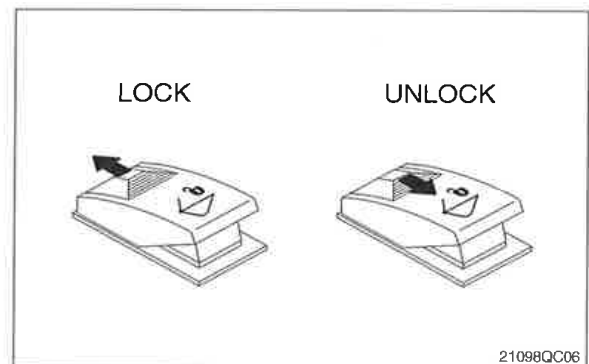





INDEX

A		G	
Accel dial switch	3-24	Gauge	3-3
After engine start	4-4	H	
Air breather element	6-30	Handsfree	3-37
Air cleaner filter	6-25	Hydraulic breaker	8-1
Air conditioner & heater	3-29	Hydraulic oil changing	6-29
Air conditioner filter	6-42	Hydraulic oil filling	6-28
Alternate exit	0-12	Hydraulic oil level	6-28
Attachment lowering	4-22	L	
B		LCD	3-5
Battery	6-39	LCD display map	3-6
Before starting engine	4-2	LCD main operation display	3-3
Boom lowering	4-22	Levers & pedals	3-27
Bucket clearance adjustment	6-37	Lifting capacities	2-6
Bucket replacement	6-35	Lubricant specification	2-28
Bucket selection guide	2-8	M	
Bucket tooth replacement	6-36	Maintenance check list	6-11
C		Major component	2-1
Cab air filter	6-42	MCU (Machine Control Unit)	3-47
Cab device	3-1	Mode selection system	4-6
Changing machine control pattern	4-25	Monitor panel	3-2
Cigar lighter	3-36	Mounting and dismounting	1-12
Cluster	3-2	N	
Coolant	6-20	New machine operation	4-1
Cooling fan	6-24	O	
D		Oil cooler	6-23
Drain filter	6-30	Operating pattern	4-25
E		P	
Emergency engine starting connector	3-48	Pedals	3-27
Engine oil filter	6-18	Periodical replacement parts	6-5
Engine oil level	6-18	Pilot filter	6-31
Engine starting & stop	4-3	Pin & bushing lubrication	6-38
Engine starting by booster	6-40	Prefilter	6-26
Engine stop	4-5	Pilot lamps	3-7
F		Q	
Fan belt	6-24	Quick clamp	8-6
Fuel filter	6-27	R	
Fuel leakage	6-28	Radiator flushing	6-20
Fuel system bleeding	6-27	Radio & CD/MP3 player	3-41
Fuel tank	6-25		
Fuse & relay box	3-47		



RCV lever lubricate	6-34
Recommended oils	2-15, 6-10
Relieving pressure	6-3
Remote controller	3-39
Return filter	6-30
RCV lever operating pattern	4-25

S

Safety hints	1-1
Safety labels	0-5
Safety parts	6-5
Seat	3-46
Seat belt	3-46
Service meter	3-48
Service socket	3-38, 3-48
Specification for major component	2-12
Specification	2-2
Start switch	3-23
Storage	4-24
Suction strainer	6-29
Swing bearing grease	6-32
Swing gear & pinion grease	6-32
Swing reduction gear oil	6-31
Switch panel	3-23
Switches	3-9, 3-23

T

Torques-major component	6-8
Torques-fastener	6-6
Towing machine	4-14
Track adjustment	6-34
Track shoe selection	2-14
Transportation	5-1
Travel reduction gear oil	6-33
Traveling machine	4-12
Troubleshooting guide	7-1

U

Undercarriage	2-10
USB socket	3-37

W

Warming up operation	4-5
Warning lamps	3-4
Weight	2-5
Windshield	3-49
Working device operation	4-11
Working method	4-15
Working range	2-4





